



**Argonne**  
NATIONAL  
LABORATORY

*... for a brighter future*

# Grazing-Incidence Insertion Device XBPM (GRID-XBPM)

- Development of high-precision hard  
x-ray beam position monitors for the  
high-power APS undulators

*Bingxin Yang*

*Accelerator Systems Division*

*Advanced Photon Source*

*September 17, 2010*



U.S. Department  
of Energy

UChicago ►  
Argonne<sub>LLC</sub>



# Outline

- (1) The undulator x-ray beam position monitor challenge
  - (A) White light vs. mono beam
  - (B) Minimal sampling vs. maximum intercept
  - (C) Photoemission-based blade (most popular)
- (2) Window-aperture XBPM
  - (A) Proposal: make the limiting aperture the beam position monitor
  - (B) Proof-of-principle tests
  - (C) Thermal-mechanical analysis
- (3) GRID-XBPM
  - (A) The proposal and proof-of-principle test
  - (B) Thermal-mechanical analysis
  - (C) Case study: IEX XBPM design
- (4) Summary and future developments

# Importance of the X-ray Beam Position Monitor

Ultimately, the x-ray beam is the final product of synchrotron radiation facilities. Beam stability is one of the most important quality factors of this product. State-of-art x-ray beamlines puts increasingly demanding requirements on beam stabilities.

APS Upgrade beam stability goals (G. Deck BIW-10)

		AC Motion* (0.1-200 Hz)		Long term (1 week, pk-pk)	
Horizontal	Now	5.0 $\mu\text{m}$	0.85 $\mu\text{rad}$	7.0 $\mu\text{m}$	1.4 $\mu\text{rad}$
	Upgrade	3.0 $\mu\text{m}$	0.53 $\mu\text{rad}$	5.0 $\mu\text{m}$	1.0 $\mu\text{rad}$
Vertical	Now	1.6 $\mu\text{m}$	0.80 $\mu\text{rad}$	5.0 $\mu\text{m}$	2.5 $\mu\text{rad}$
	Upgrade	0.42 $\mu\text{m}$	0.22 $\mu\text{rad}$	1.0 $\mu\text{m}$	0.5 $\mu\text{rad}$

APS current = 150 mA after upgrade (> 17 kW undulator power).  
Front end components design goals: 200 mA (> 23 kW)

# First Challenge of the XBPM: White vs. Mono Beams

Most users need only the monochromatic core of the undulator beam: angular divergence  $\sim \sqrt{\lambda/nL} \otimes \sigma_{x'}$ . We cannot perform direct measurement on this beam for practical reasons:

- (A) Characterizing this beam requires a high-power monochromator at correct setting;
- (B) Intercepting this beam interferes with user experiments, by adding undesirable spectral features to the x-ray beam, distorting the wavefront of the x-ray beam, or simply reducing photon flux.

Therefore we are always forced to measure the white (wrong) beam!

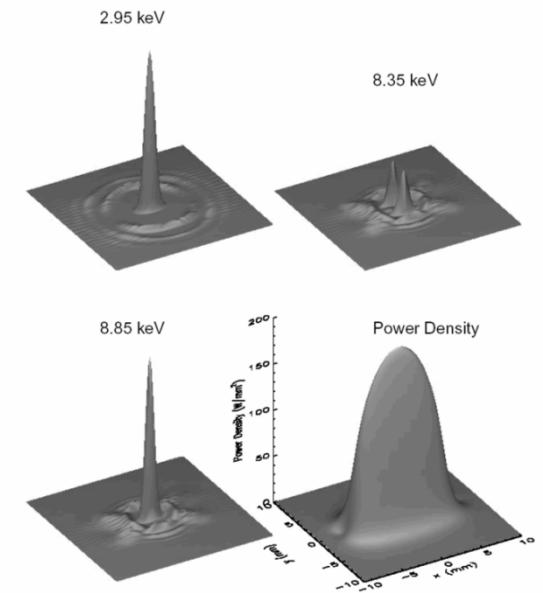

## Second Challenge: Large Beam vs. Small Displacement

A standard electron beam stability specification is 5 – 10% of the beam size, reflecting the fact that larger beam size makes the centroid measurement less accurate. However, the requirement for a 3-mm wide (rms) white undulator beam is often stated as 3 – 10  $\mu\text{m}$ , representing only 0.1 – 0.3% of the beam size!

These challenges tempted many people into trying their hands on solving the problem. Two schools of thoughts:

**(1) Minimal intercept** → sampling the wings of the white beam

**(2) Maximum sampling** → measuring the entire x-ray beam to the extent possible. For example, center of mass (CM) measurements.

# Sampling XBPM: Gaussian Beam Approximation

Many photoemission XBPMs employ four or more sampling blades symmetrically placed in the “wings” of the beam, and use the photocurrent imbalance, the difference/sum term  $\Delta/\Sigma$ , as the position signal.

$$R_{PE}(y_0) = \frac{(A+C) - (B+D)}{(A+C) + (B+D)}$$

For a vertical displacement  $b$ , the BPM signal for a Gaussian beam is,

$$R_{PE}(y_0) = \frac{\operatorname{erfc}\left(\frac{b-y_0}{\sqrt{2}\sigma_y}\right) - \operatorname{erfc}\left(\frac{b+y_0}{\sqrt{2}\sigma_y}\right)}{\operatorname{erfc}\left(\frac{b-y_0}{\sqrt{2}\sigma_y}\right) + \operatorname{erfc}\left(\frac{b+y_0}{\sqrt{2}\sigma_y}\right)}$$

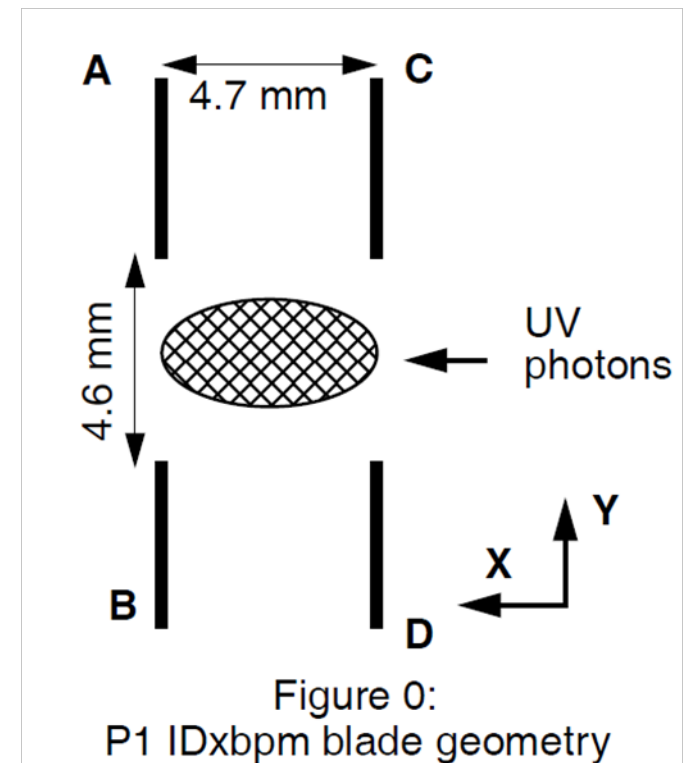

# Sampling XBPM: Calibration length

The response curve of the BPM signal,  $\Delta/\Sigma$ , has the familiar S-shape curve. The inverse of its slope at the center, the calibration length, is given by

$$l_y = \sqrt{\frac{\pi}{2}} \sigma_y e^{\frac{b^2}{2\sigma_y^2}} \operatorname{erfc}\left(\frac{b}{\sqrt{2}\sigma_y}\right)$$

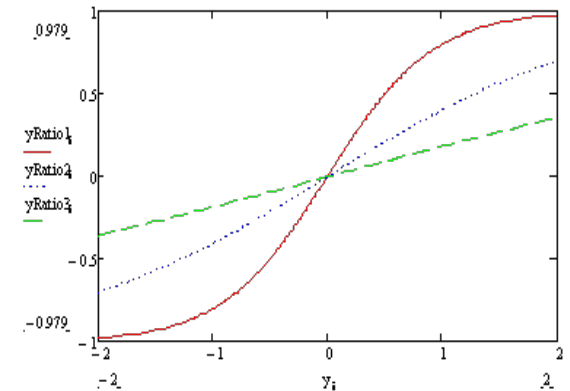

## Properties of sampling XBPM

1. Minimal intercept of undulator beam;
2. Power load easy to manage;
3. Moving the blades away from the center improves the XBPM sensitivity and reduces the power load;
4. Moving the blades away also makes the XBPM more vulnerable to bend magnet radiation interference or effect of undulator field errors.

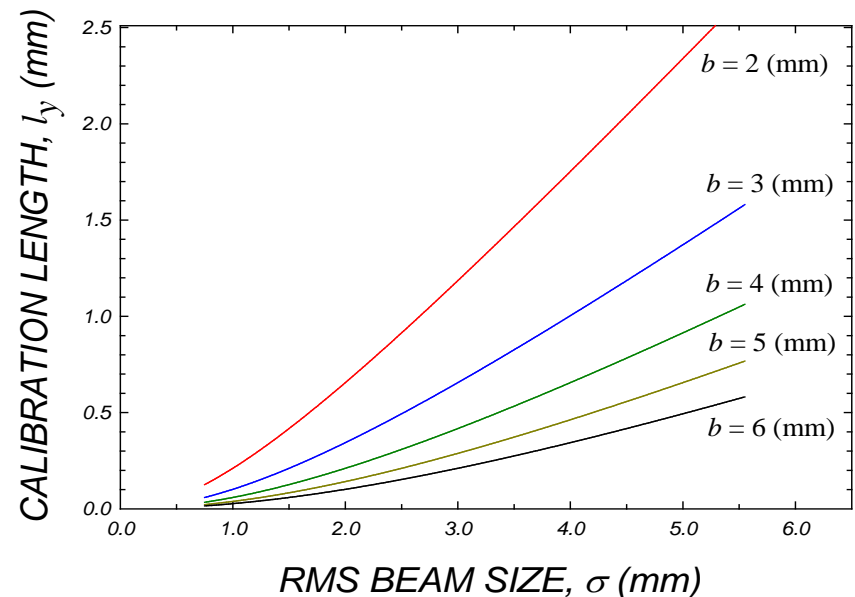

# Photoemission-Based Blade XBPM

## Construction:

- X-ray photoemission blades (tungsten, metal-coated diamond, ...)
- Ceramic support provides electrical insulation and cooling.

## Pros:

- Simple in construction,
- Robust and reliable in operation (survived mis-steerings)

For decades, it is the workhorse for many light sources around the world.

## Cons:

- Electrical center is not well defined (blade alignment or BM radiation?)
- Calibration is gap dependent
- Background from bend magnet and correctors interfere with XBPM operations.
- Thermal distortion of blade and support has not been studied.



# Photoemission XBPM: Gap dependence compensation

In the APS, Glenn Decker spent many hours studying and modeling the XBPM over the course of a year. “Started with gap-dependence of hundreds of microns, I eventually compensated most of the error and brought the gap-dependence to tens of microns.” (Glenn Decker: Electronic Fiducialization of Insertion Device Photon Beam Position Monitors, OAG-TN-2004-033, September 20, 2004)

The blade-type XBPM will not be adequate for the stringent APS upgrade specifications. Hard XBPM, immune to soft radiation from bend magnet and corrector magnets, has to be developed. In fact these BPMs have been in development for several years in the APS\*.

Recently, we have started a new design approach, which will be reported in the remainder of this talk.

\* Development of a Hard X-ray Beam Position Monitor for Insertion Device Beams at the APS Glenn Decker, Gerd Rosenbaum, and Om Singh. BIW06

# Unsolved Problem for Blade XBPM: Elliptically Polarized Undulator

X-ray intensity distribution of an elliptically polarized undulator does not have a single peak, sampling XBPMs do not work at all. Only XBPMs intercepting a large portion of the beam (*maximal intercept*) may work.

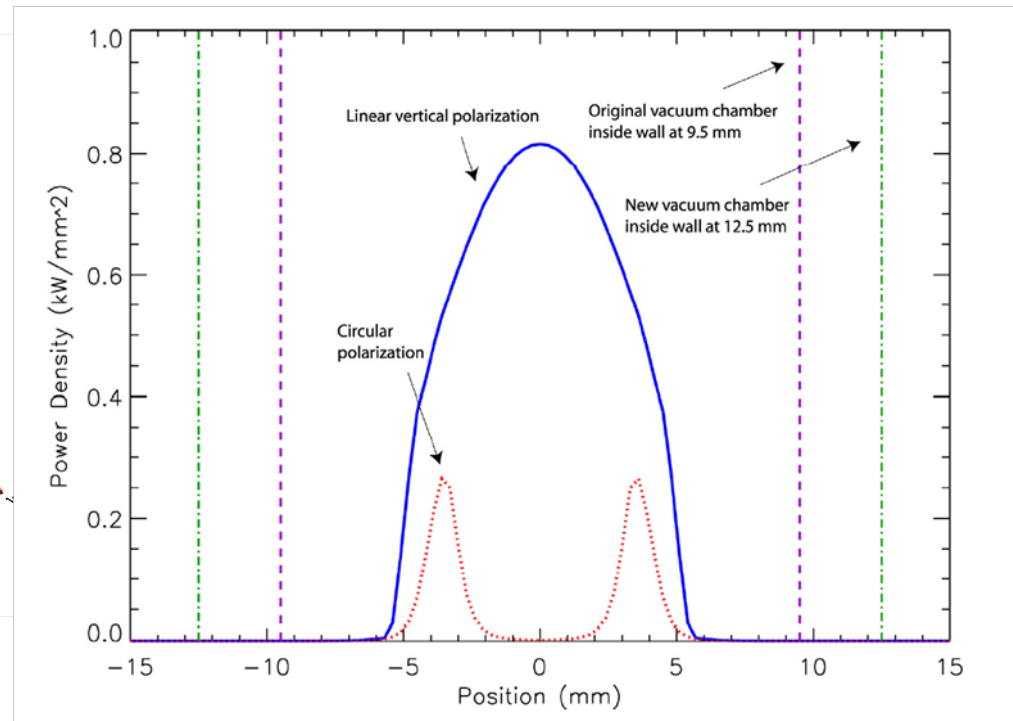
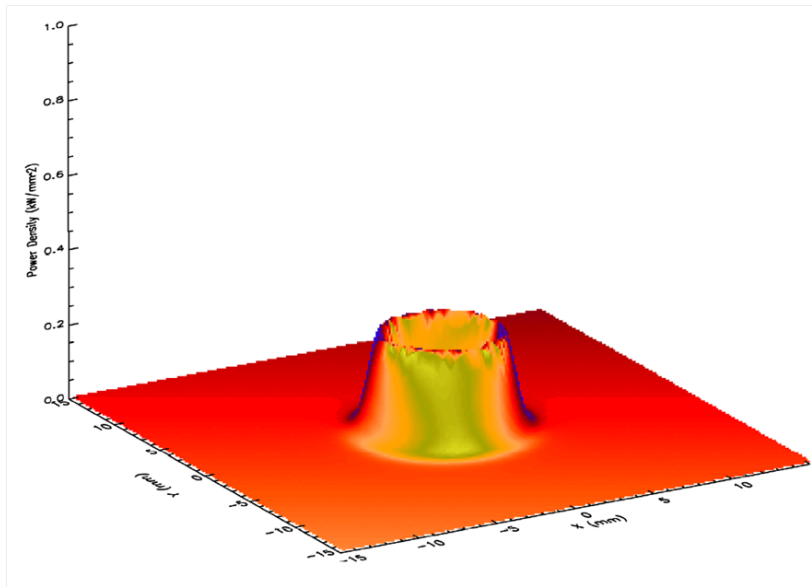

From R. Dejus and M. Jaski, MD-TN-2009-003

## 2. Maximal Intercept, Even Center of Mass Measurement

The school of maximum intercept believes: the more we intercept the white beam, the more useful the signal is, and the more accurate the measurement is. The ultimate goal is 100% sampling and center of mass (CM) measurements. Many sampling media were tested:

- (1) Residual gas XBPM (Petr Ilinsky, DESY/NSLS II, BIW10)
- (2) X-ray windows (commercial product from Diamond Materials)
- (3) Holed or slotted x-ray targets (these proposals)

The last proposal is not a optimal XBPM. We are only compelled to it by the power / power density of the APS undulator beam.

# A Center of Mass XBPM Using Quad Detectors

Segment detectors are sampling position detectors. However, it is possible to perform center-of-mass measurements by adding an aperture (pinhole) optics before the segment detectors (B. X. Yang, et al. BIW-10)

$$R(\bar{y}) = -\frac{I_+ - I_-}{I_+ + I_-} = \frac{M \int \rho(y) y dy}{a \int \rho(y) dy} = \frac{M}{a} \bar{y}$$

Calibration length proportional to field of view → large beam makes less sensitive measurements.

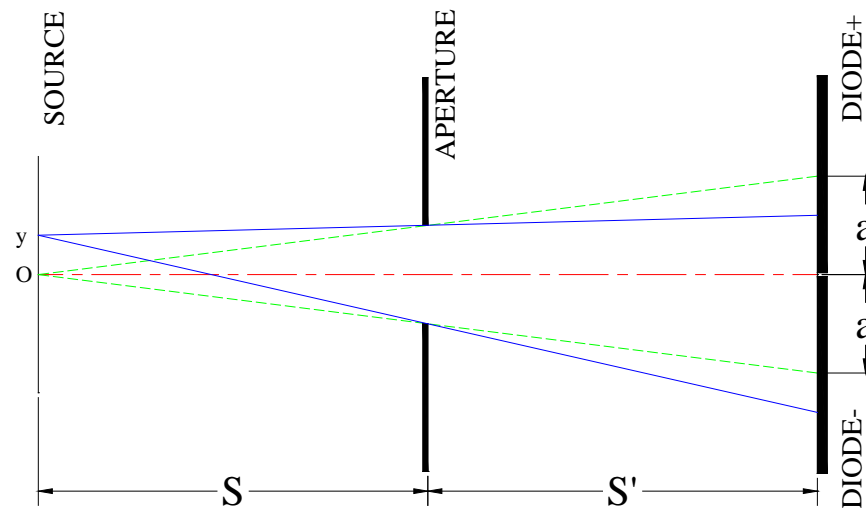

# Slot XBPM: The Concept

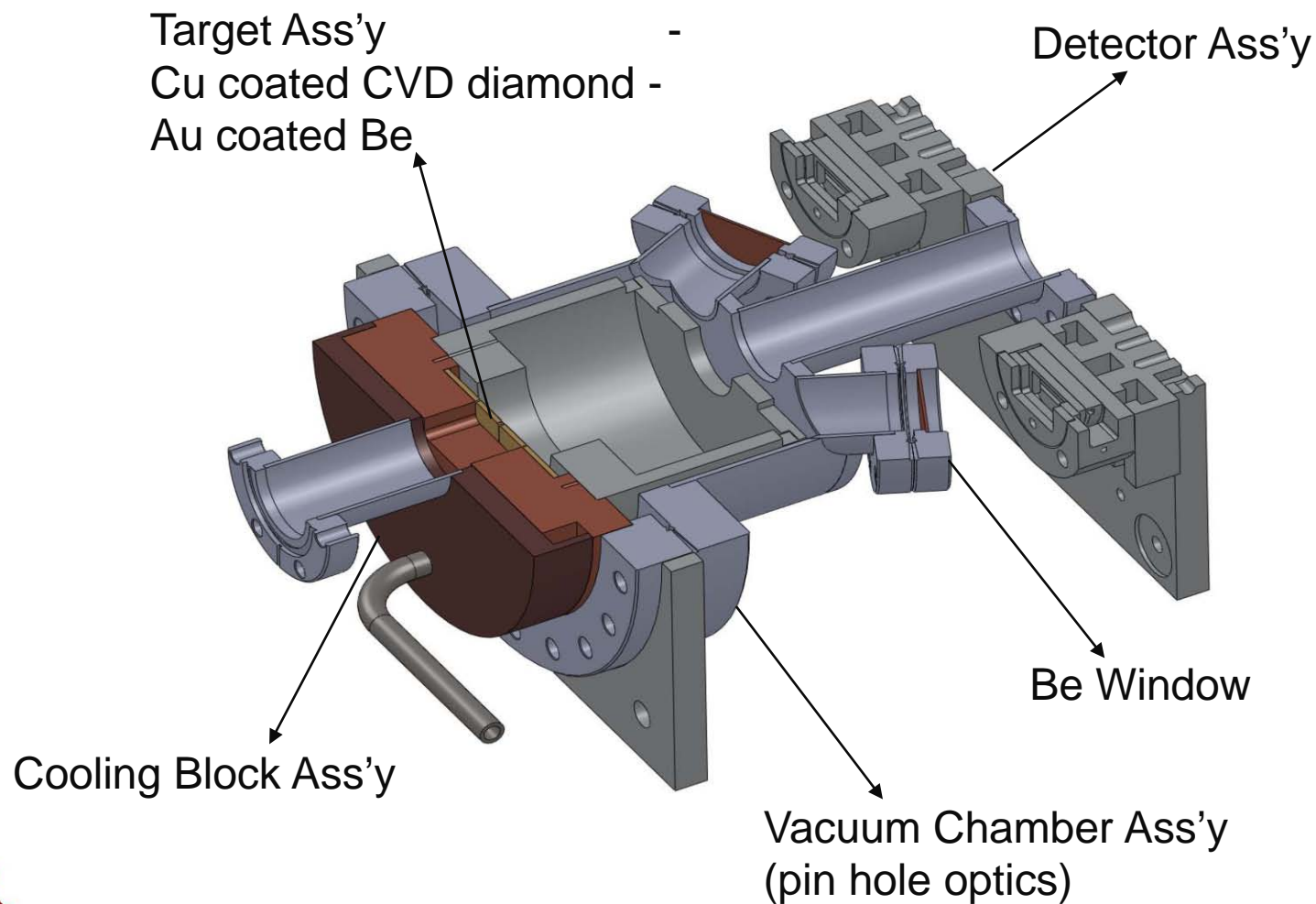

B. X. Yang: 2-D sketch. S.-H. Lee: 3-D model.

# Slot XBPM: A Proof of Principle Test

Model slot XBPM: Copper plates

Position readout: Two-dimensional CM-detector.

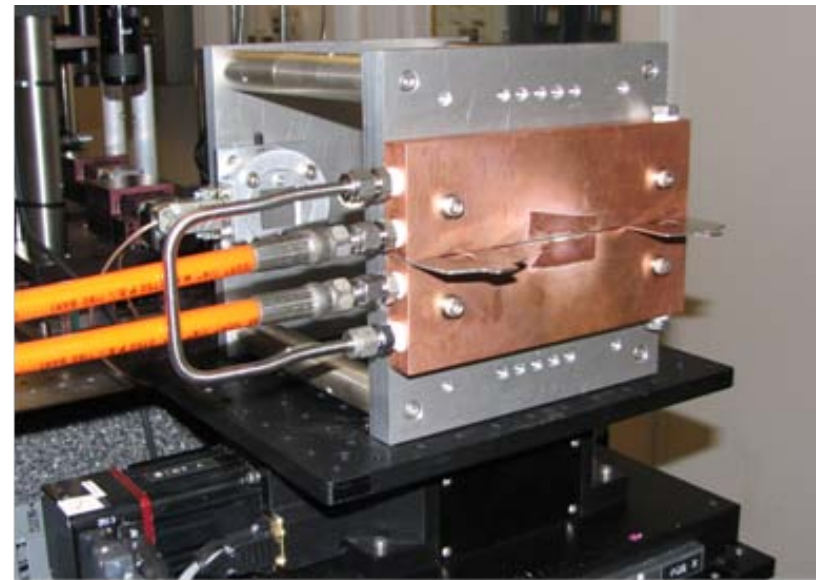
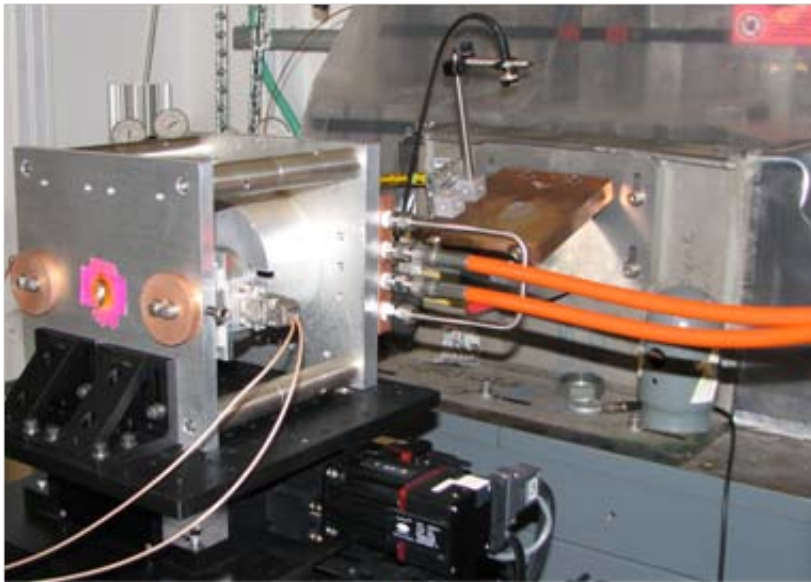

# Slot XBPM: Test Data

Vertical profile through the slot is in the form of modified Gaussian,

$$S_f = S_{f0} e^{-\frac{1}{2} \left| \frac{y_b}{\sigma} \right|^2}$$

as seen in computer simulations.

Calibration performed by scanning XBPM.

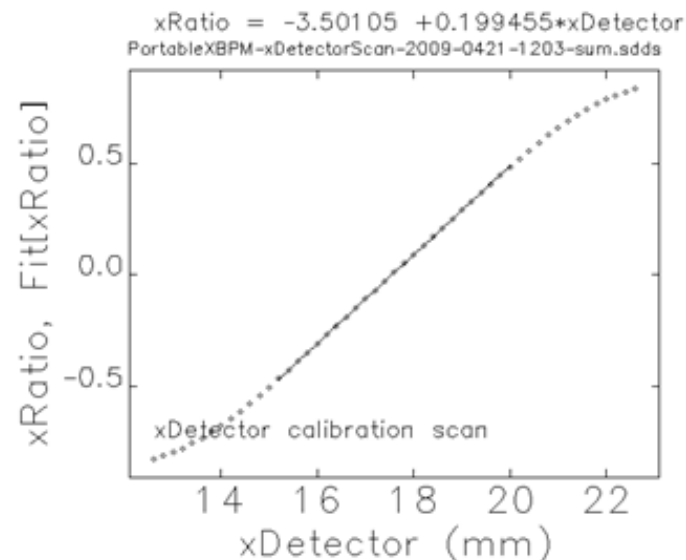
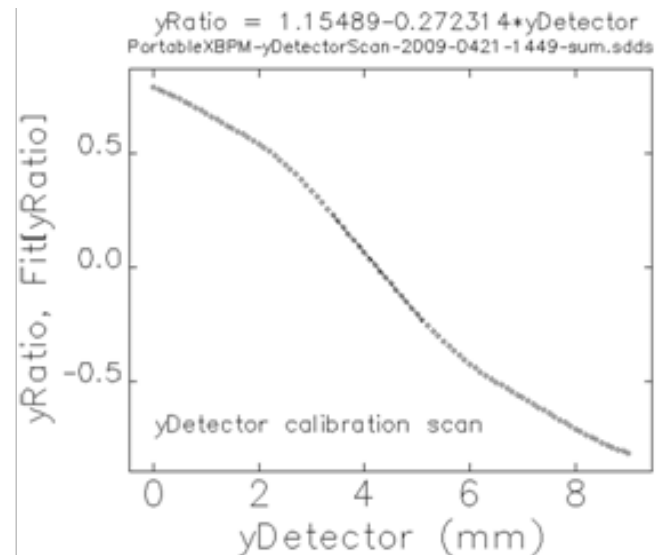
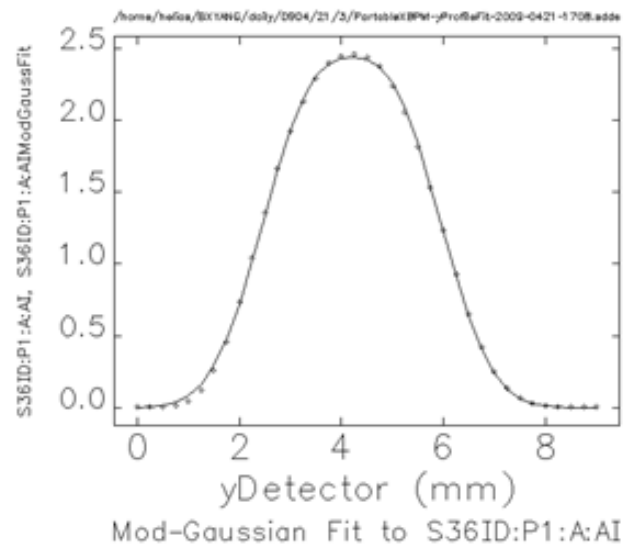



# Slot XBPM: Gap Dependence in vertical direction

Due to its construction, little horizontal gap dependence is observed. Some gap dependence in the vertical direction are seen. But due to limited power of the Diagnostics Undulator, it is not possible to perform a full test.

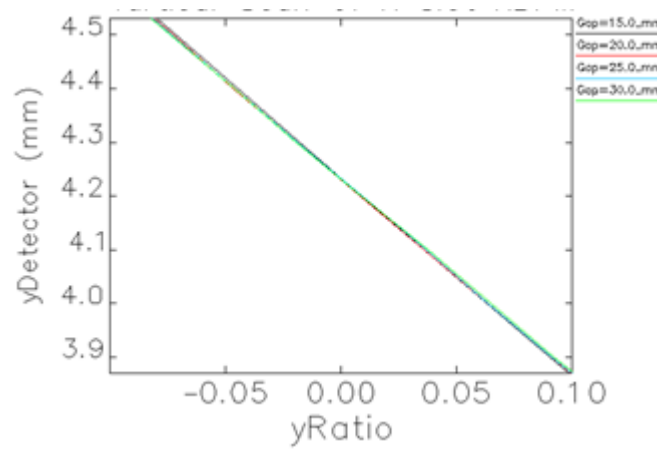
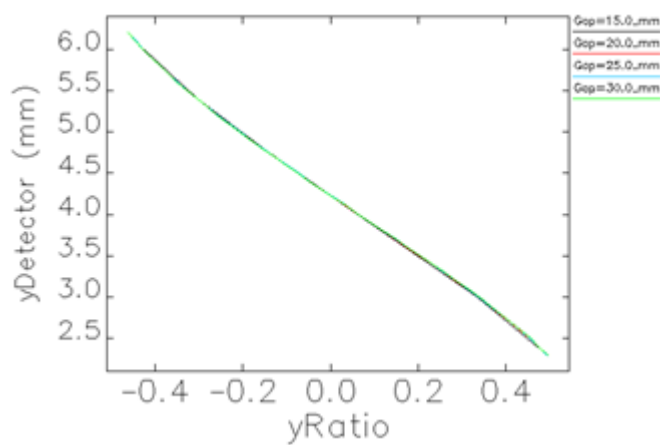

Table 3-3: Coefficients of polynomial fit to XBPM vertical scan data

Undulator Gap	Gain	Sum Current	Intercept (a0)	Slope (a1)
15 mm	5	82.2 $\mu$ A	4.2287	-3.59132
20 mm	6	14.2 $\mu$ A	4.2280	-3.54500
25 mm	6	2.50 $\mu$ A	4.2285	-3.53396
30 mm	6	0.45 $\mu$ A	4.2288	-3.50988
30 mm	7	0.45 $\mu$ A	4.2407	-3.51199



# Slot XBPM: A Failed Stability Test

35  $\mu\text{m}$  drift was seen over 12 hours:

- Beam motion?
- Temperature change in the night?
- Detector degradation?
- A clue: 10% loss in intensity.

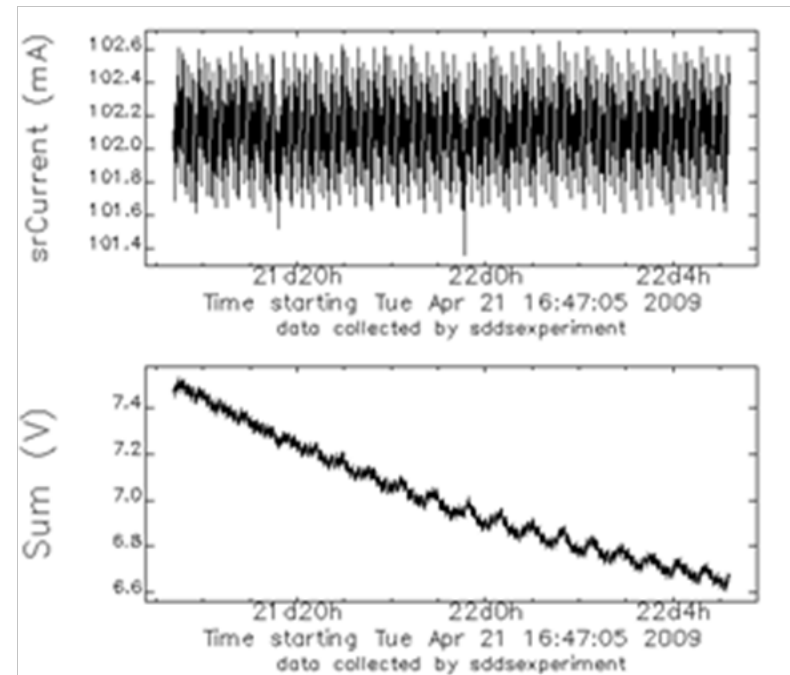
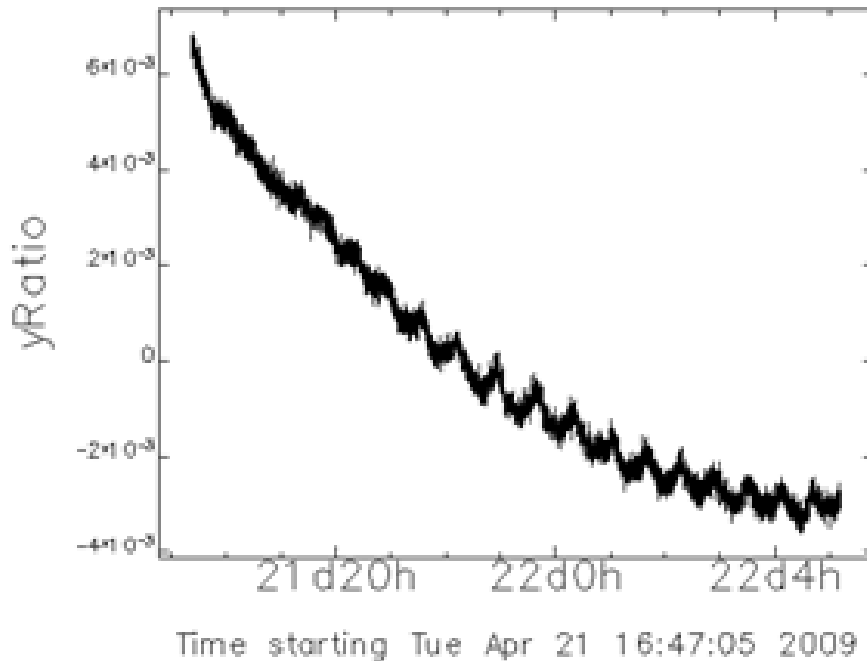

# Slot XBPM: Stability Test

A thick layer of oxide were built up around the beam spot.

Although the stability test result is not valid, we are happy to learn that XRF-based hard XBPM are very robust against surface changes.

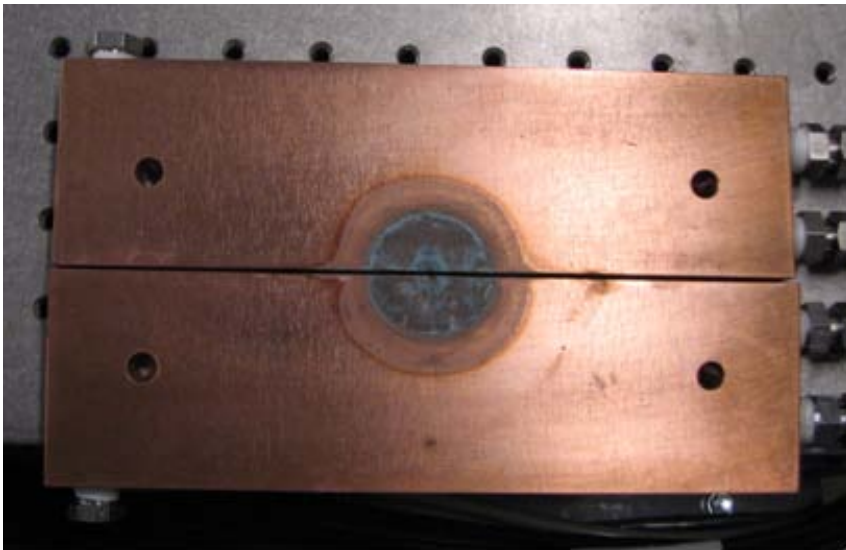

Oxide build-up in x-ray beam.



Cleaned up again.

# Slot Diamond XBPM: Thermal Calculation by Soon-Hong Lee

## CASE II-7: Absorption Power Density (2.0 mm CVDD + 1 μm Cu coating)

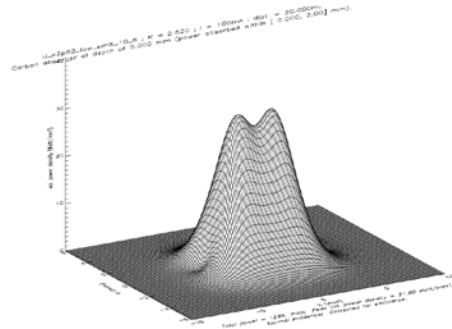

$$\text{Fit} = \exp(4.1526 - 0.070546x^2 - 0.29128y^2 - 0.0015362x^4 - 0.00050863y^4 + 0.0041385x^2y^2)$$

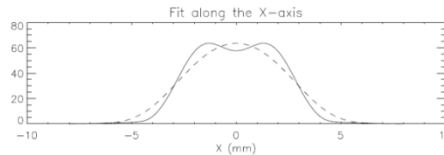
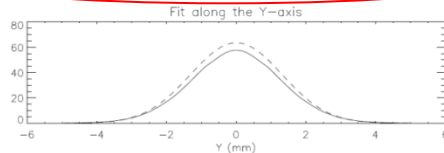

CVDD (2.0mm)

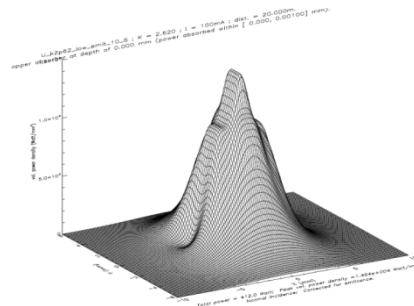

$$\text{Fit} = \exp(2.7038 - 0.11331x^2 - 0.14807y^2 + 0.00065187x^4 + 0.0011609y^4 + 0.0022580x^2y^2)$$

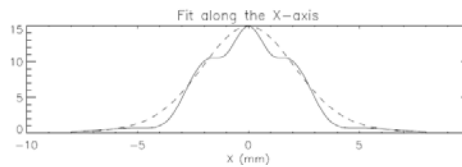
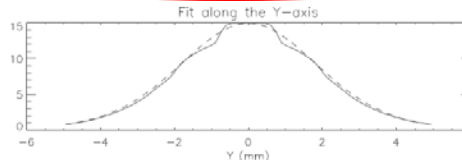

Cu (0.001mm)

Calculated absorption power density distribution @ 20m from the Gaussian fitting formula

Curve fitting of absorption power density distribution @ 20m from the Gaussian fitting formula

The fitted formula will be used in ANSYS for the thermal load application.

Location	Cu layer (1 μm)		CVDD (2.0 mm)	
	Integrated raw power	Integrate fitted power	Integrated raw power	Integrate fitted power
@ 20 m	412.0 ( 14.94 W/mm <sup>2</sup> )	412.96	1,265.7(63.60W/mm <sup>2</sup> )	1,264.1

Power Absorption Calculation (Watts)

Slide courtesy of Soon-Hong Lee

# CASE III: Simulation Result – CVDD 2.0 mm + Cu 1 $\mu\text{m}$ Thick + $\phi$ 1.0 mm center hole

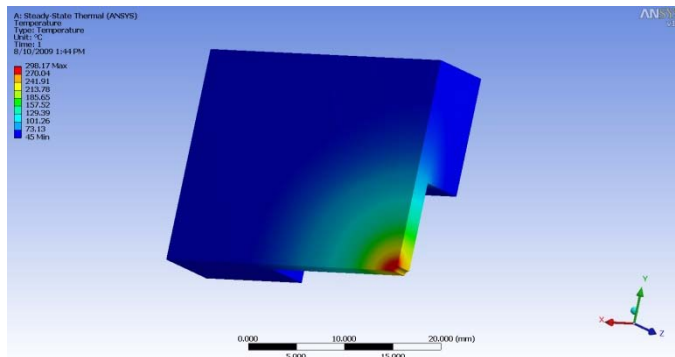

Temperature

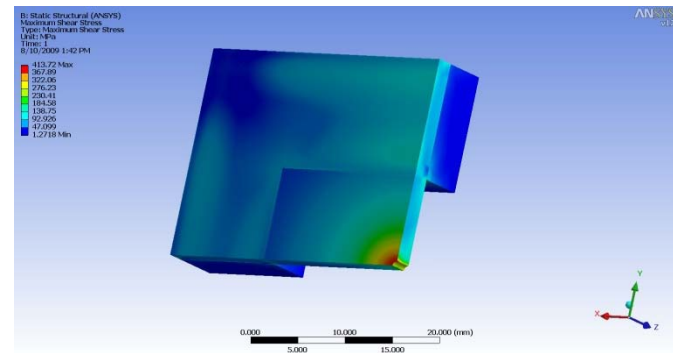

Max. Shear Stress

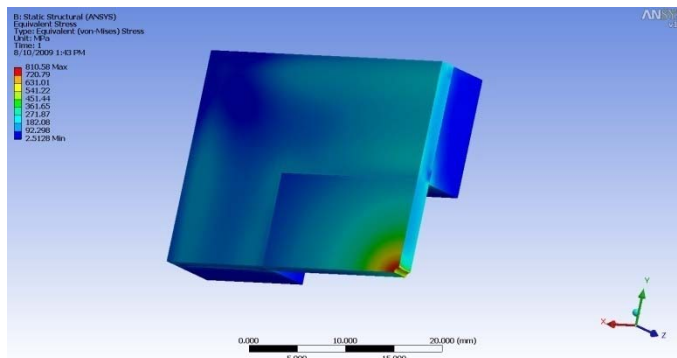

Von-Mises Stress

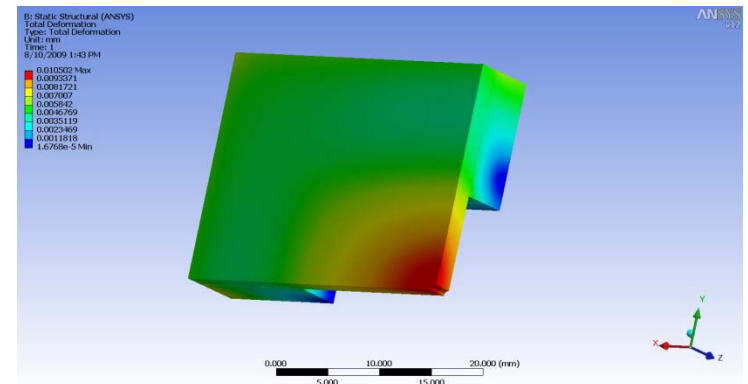

Displacement

Slide courtesy of Soon-Hong Lee

# CASE VI: Simulation Result – missteered beam & $\phi 1.0$ mm hole

Case	Hole Dia. (mm)	Off-center L x H (mm x mm)	Cu Thick. ( $\mu\text{m}$ )	Cu Absorpt. Power (W)	CVDD Thick (mm)	CVDD Absorpt. Power (W)	Integrated Raw Power (W)	Simulation Results @ 20 m				
								Simulated Reaction Power (W)	Temp. ( $^{\circ}\text{C}$ )	V-M Stress (MPa)	Max. Shear Stress (MPa)	Disp. ( $\mu\text{m}$ )
III	-	-	1	412.0	2	1,265.7	1,677.7	1,694.88	320.87	838.25	421.69	10.823
VI	$\phi 1.0$	0.0 x 0.0	1	< 412.0	2	< 1,265.7	< 1,677.7	1,634.68	298.17	810.58	408.67	10.502
		2.5 x 0.0						1,659.18	313.57	814.78	409.26	10.769
		<b>5.0 x 0.0</b>						1690.24	<b>315.79</b>	<b>821.78</b>	<b>413.27</b>	<b>10.800</b>
		7.5 x 0.0						1694.38	311.36	807.97	406.31	10.677
		10.0 x 0.0						1,691.52	303.73	783.75	394.07	10.550
		12.5 x 0.0						1,681.70	291.01	742.84	373.42	10.463
		15.0 x 0.0						1,644.48	267.98	765.17	435.53	10.374

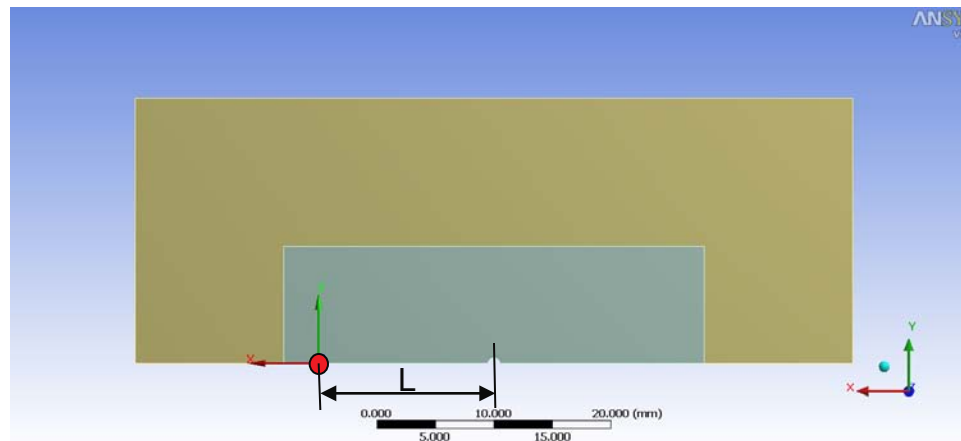

Slide by Soon-Hong Lee

# Slot XBPM Summary

## Scaled Tests:

- CM measurements in horizontal plane: Little gap dependence observed.
- Maximum sampling in the vertical plane: Electric center is nearly independent of undulator gap. Calibration may be corrected with gap-dependent coefficients.

Very promising!

## Thermal calculations (Soon-Hong Lee and Pat Den Hartog):

- Beryllium windows / slot will not survive undulator beam.
- Thick (2-mm), optical grade diamond window may work for one Undulator A at 100mA.
- This thick diamond window / slots will not survive 150 mA, 2 UA operations. Most likely mode of destruction: mis-steered beam at closed gap.

**Question: What if we make the slots in grazing incidence? !**

### 3. Grazing-Incidence Insertion Device XBPM Proposal

Key idea:

- Slice the GlidCop beam aperture into two
- Imaging the x-ray fluorescence footprint using aperture optics
- Readout the XRF image with multi-element detectors
- Compensate for the gap dependence with FPGA, etc.
- The entire assembly is mounted on one precision table.

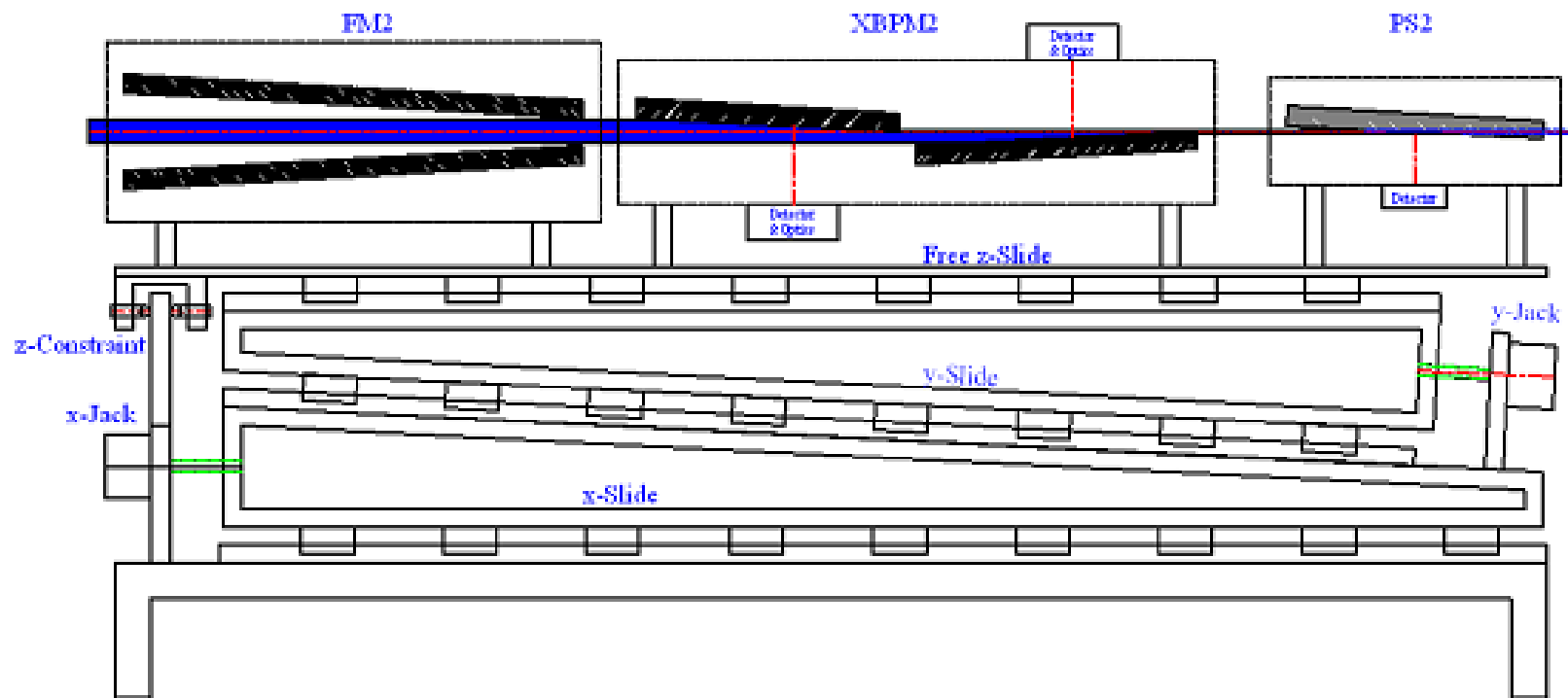



# GRID-XBPM: A Proof of Principle Test

Issues:

Aperture (pinhole) optics setup.

Center-of-mass vs. sampling measurements

Powder diffraction from GlidCop collimator

Sensitivity to alignment

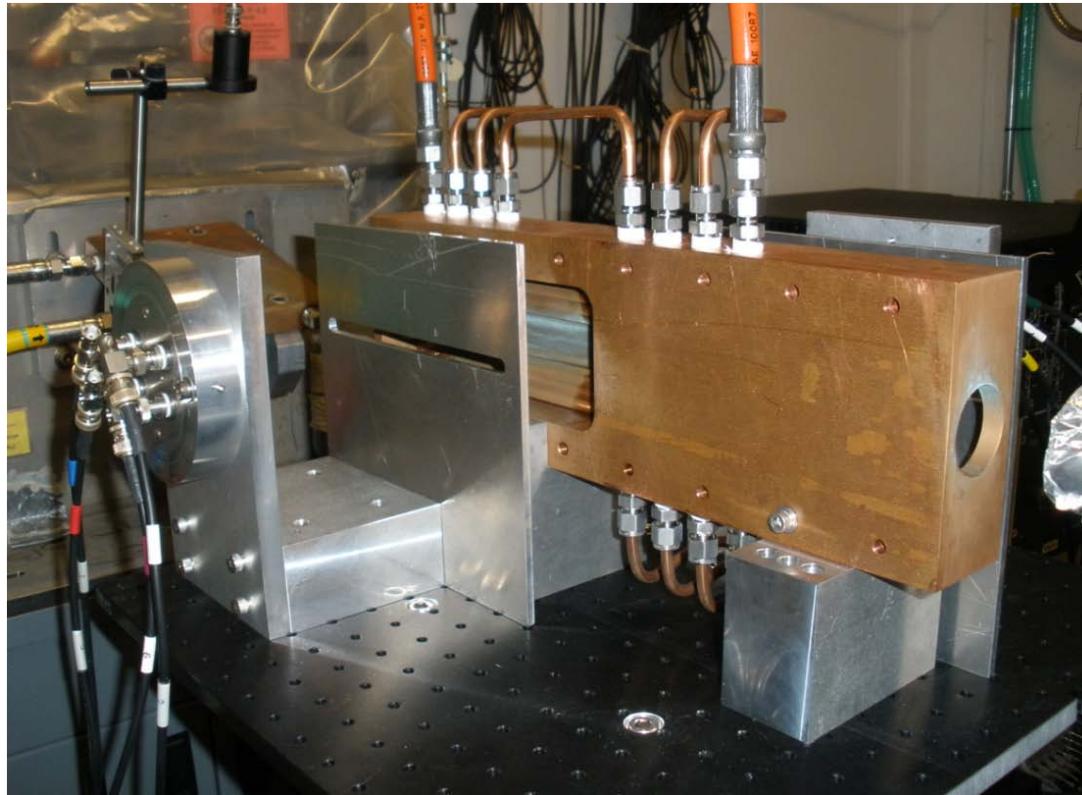



# GRID-XBPM Noise and Background: BM Radiation

Gap dependence: Absence of bend magnet radiation interference

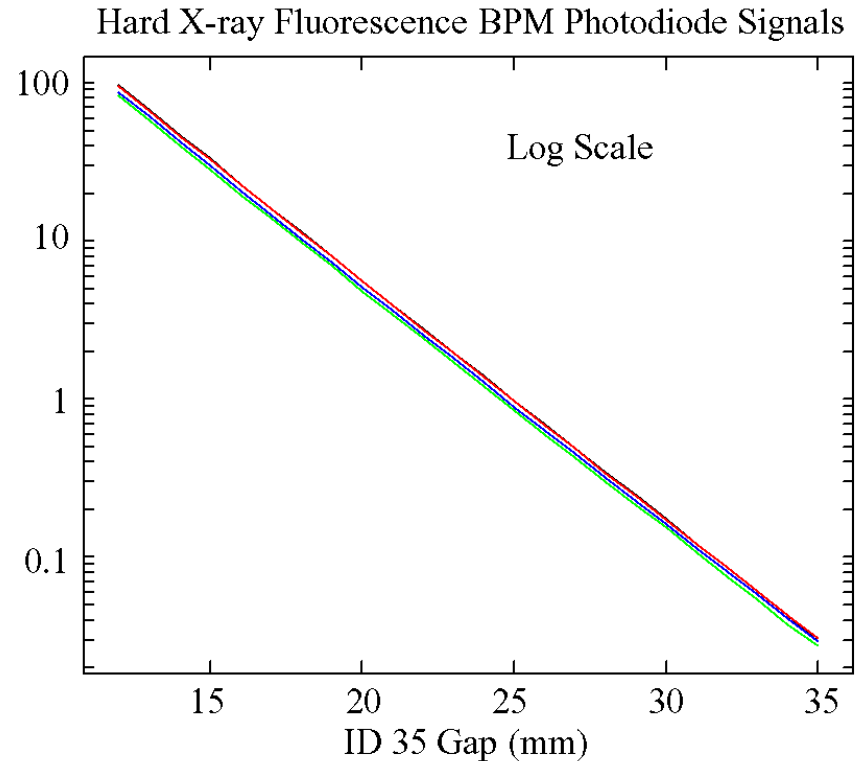
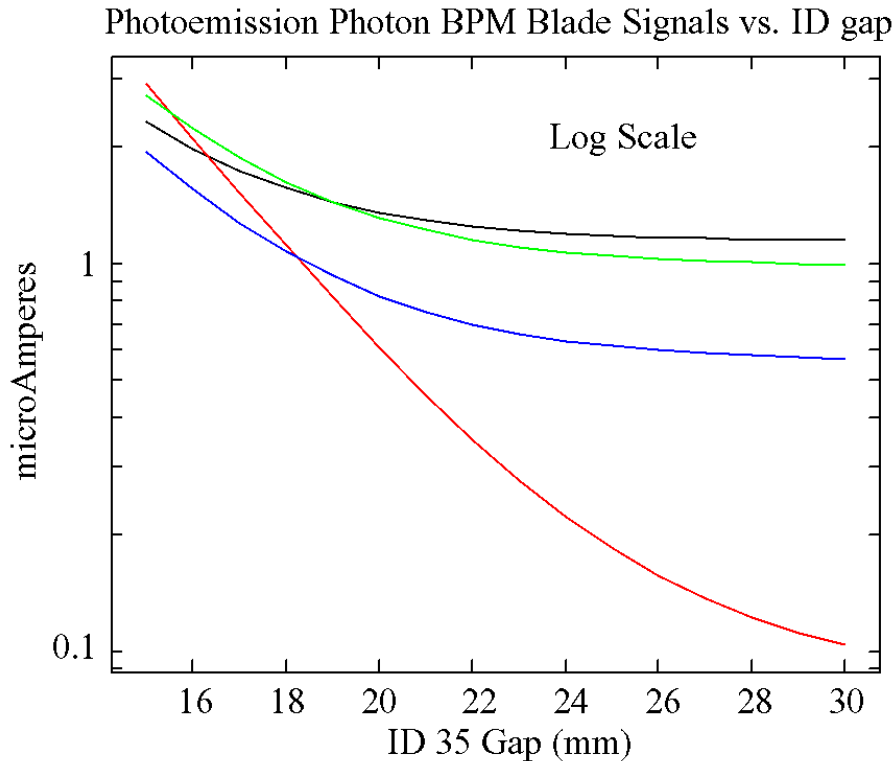

Data courtesy of Glenn Decker and Bingxin Yang

# GRID-XBPM Test: Lessons learned

In the vertical plane, we have CM measurement.

- Weak dependence with undulator gap but not zero. Alignment issue?

In the horizontal plane

- CM measurement failed: stringent alignment requirement is too difficult to achieve.
- Use intensity sampling measurement: Found stronger gap dependence.

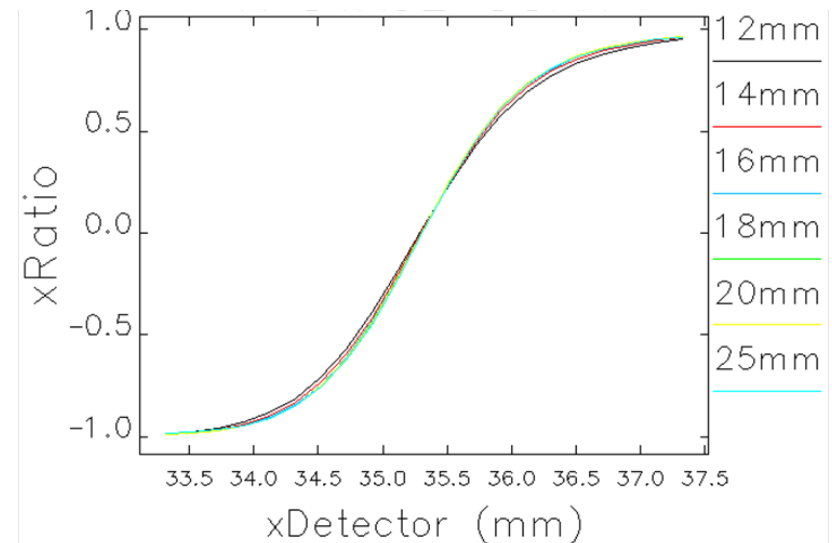
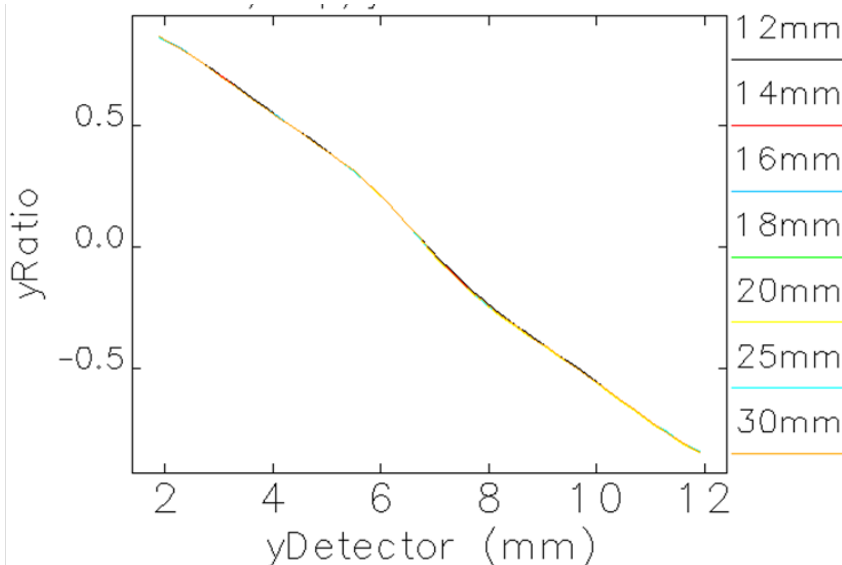
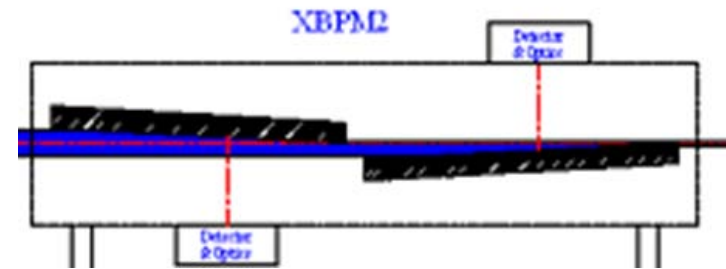

# GRID-XBPM Noise and Background: Powder Diffraction

Observed powder diffraction peaks at 23 keV (35-ID) when detector is 50+cm from target.

- Diffraction intensity  $\sim 1/r$  vs. XRF intensity  $\sim 1/r^2$ . Shorter distance and larger angle range  $\rightarrow$  Less pronounced peak
- Larger diffraction angle  $\rightarrow$  lower x-ray energy, weaker diffraction lines.
- Symmetry leads to strong cancellation.
- Study continues...

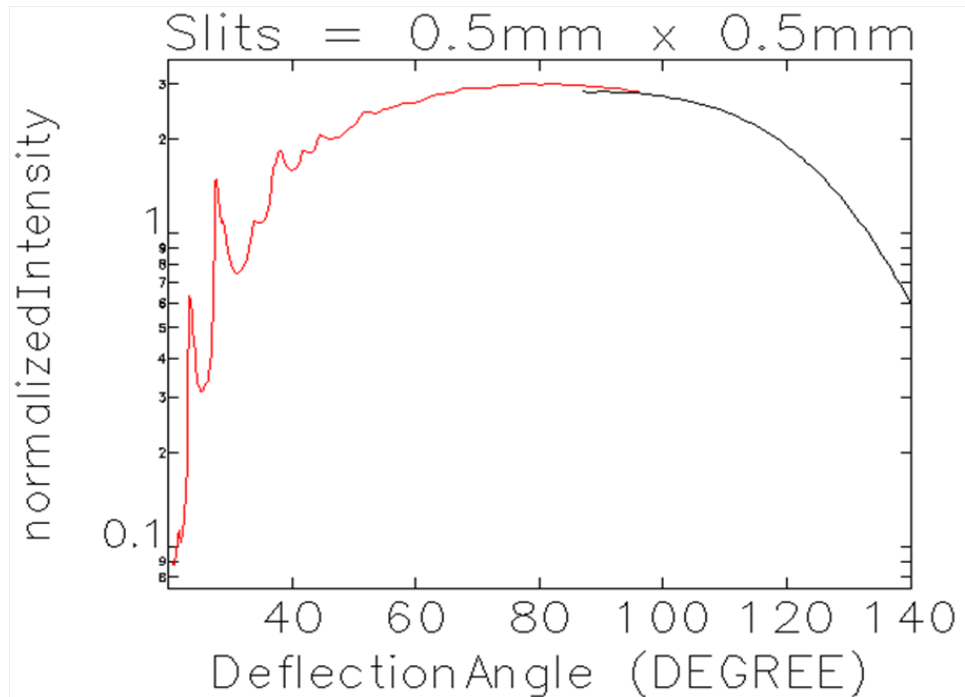

# GRID-XBPM: Thermal Calculation by Soon-Hong Lee

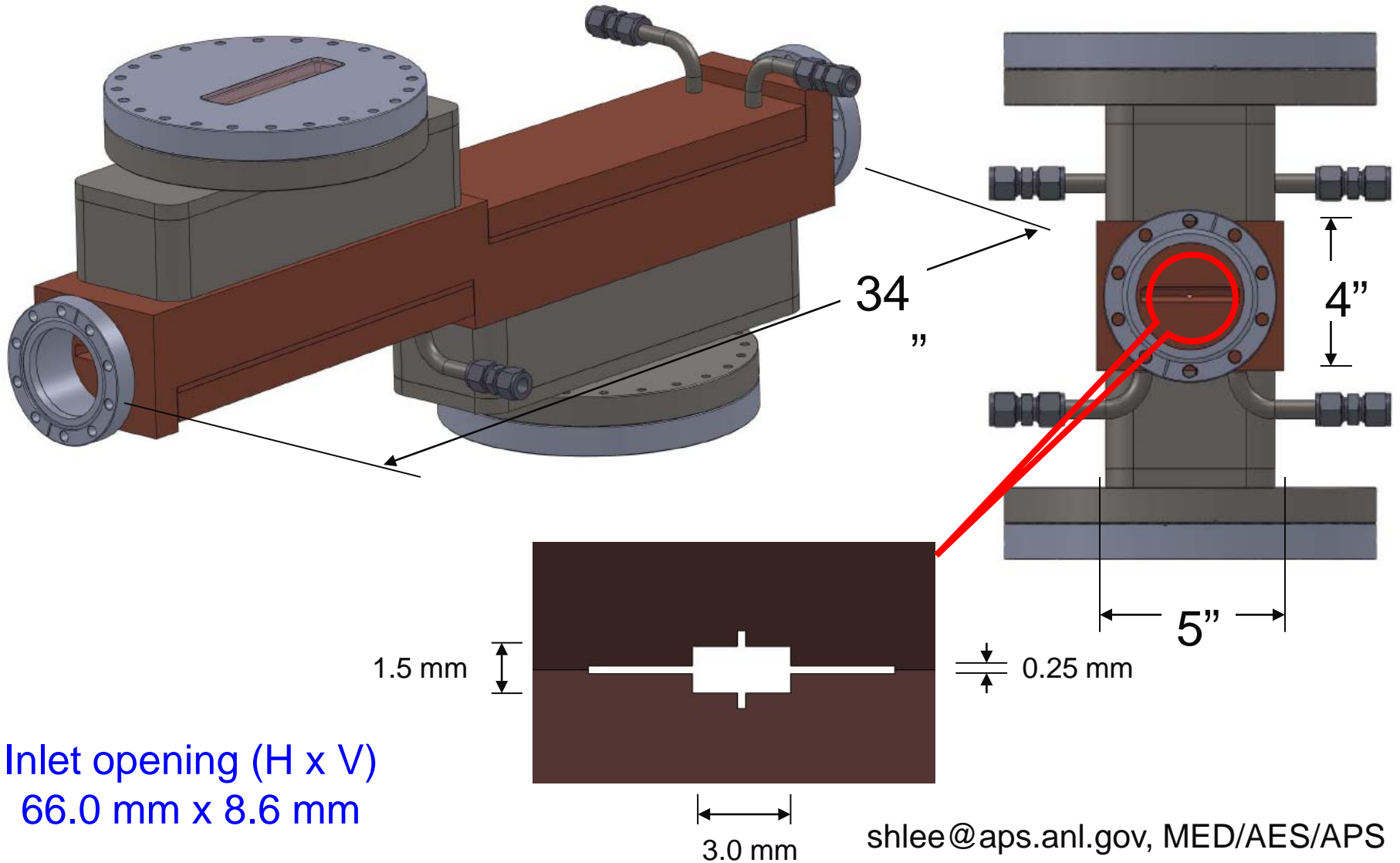

# Simulation Result (10650W + Vacuum)

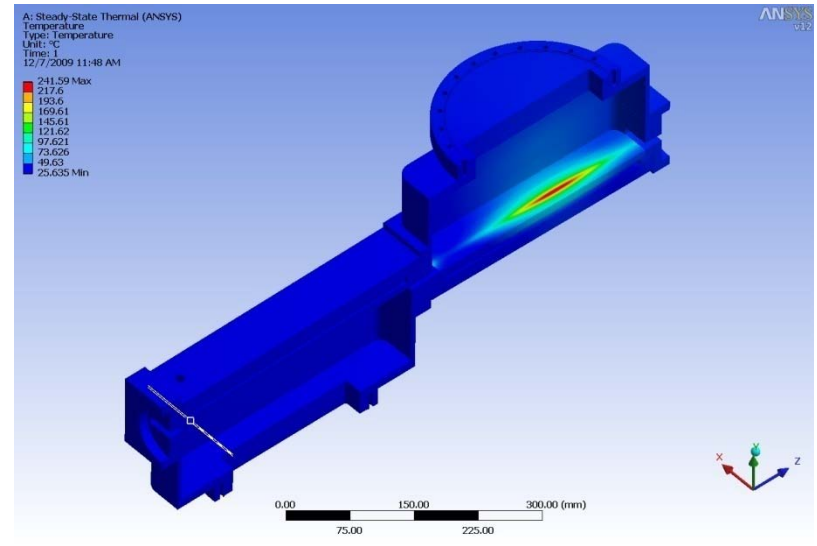
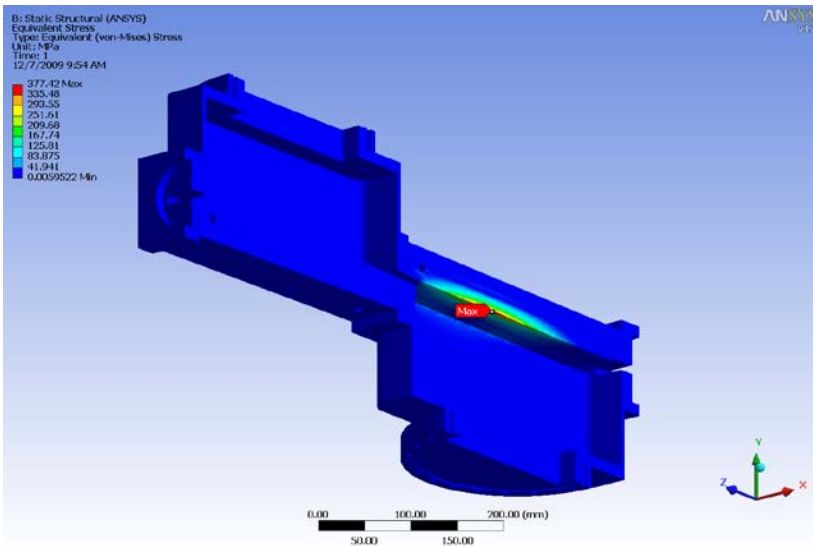

Temperature Distribution @ Case 3 (Max. 241.6 °C)

Stress Distribution @ Case 6 (Max. 377.4 MPa)

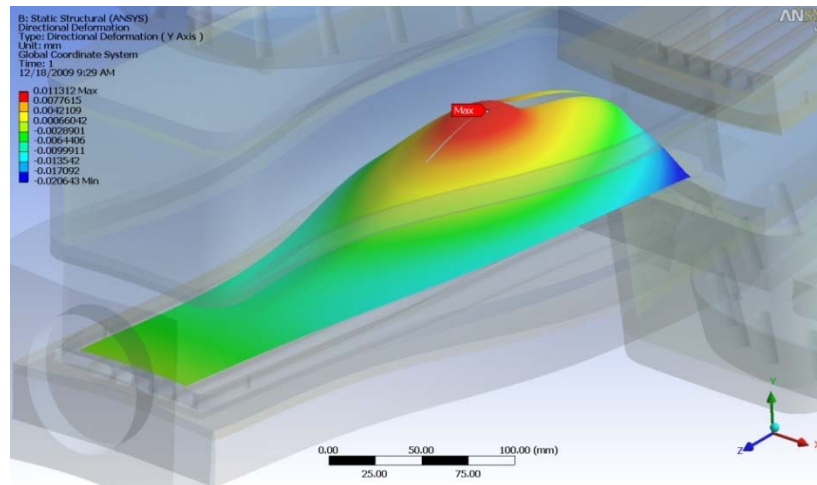

Red: 11.3  $\mu\text{m}$   
 Blue: -20.6  $\mu\text{m}$

Surface deflection @ Case 1 (Vertical direction only, 2100x)

shlee@aps.anl.gov,  
 MED/AES/APS

# Reference II - ~20kW & Vertical Orientation

Case	Beam center coordinate (x, y) (mm)	Mis-steering Case	Film coefficient (W/mm <sup>2</sup> /°C @ 25.6°C)	Simulation Results @ 19.35 m			
				Reaction Power (W)	Max. Temp. (°C)	Max. Cooling Wall Temperature (°C)	Max. Von-Mises Stress (MPa)
1	(0,0)	Beam centered	0.010	14,494	183.3	76.3	290.2
2	(-0.5, 0)	Hor. mis-steering	0.010	14,574	197.7	81.6	320.8
3	(-3, -5)	Hor. & Ver. mis-steering	0.010	20,819	101.6	427.8	
Requirements				21,300	< 300 °C	< 150 °C	<427MPa (25mm Thk) <455MPa (16mm Thk)

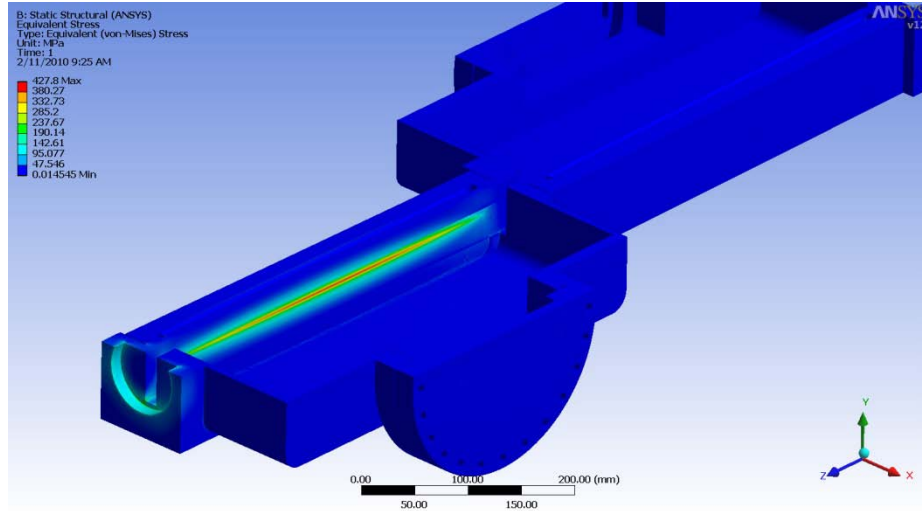
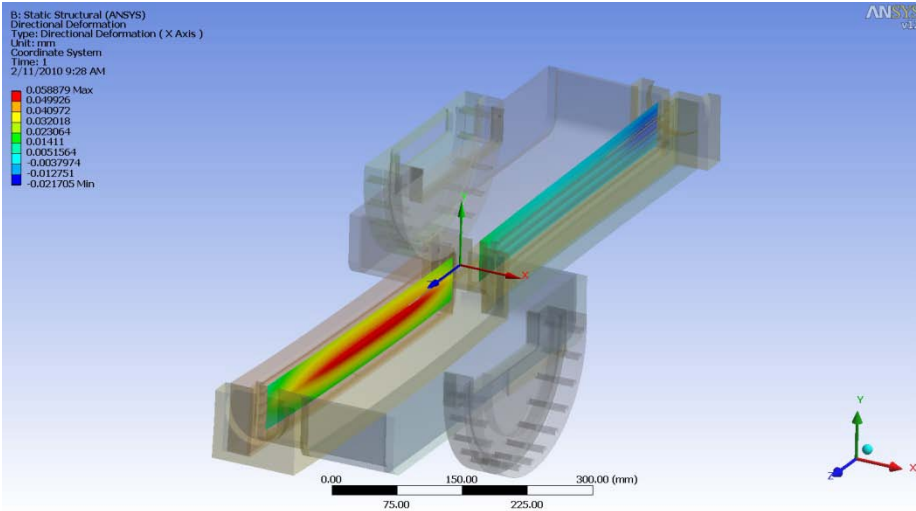

Case 3:  
 Upstream: 58.9  $\mu\text{m}$  bump (was 27.7  $\mu\text{m}$ ),  
 Downstream: 21.7  $\mu\text{m}$  bump (was 10.6  $\mu\text{m}$ )

Stress Distribution @ Case 3 (Max. 427.8 MPa)

shlee@aps.anl.gov, MED/AES/APS

# Reference II – Beam bump at ~20kW @y=-0.127mm

Comparison of Beam Centered and Missteered Cases  
(X-direction displacement: Horizontal direction bump only)

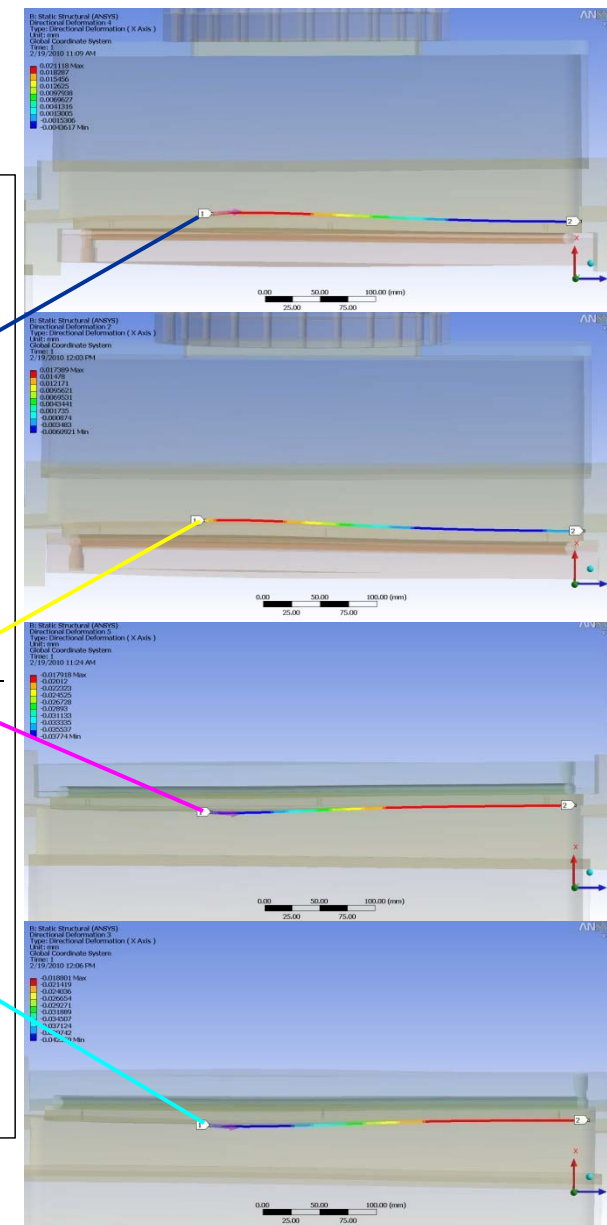
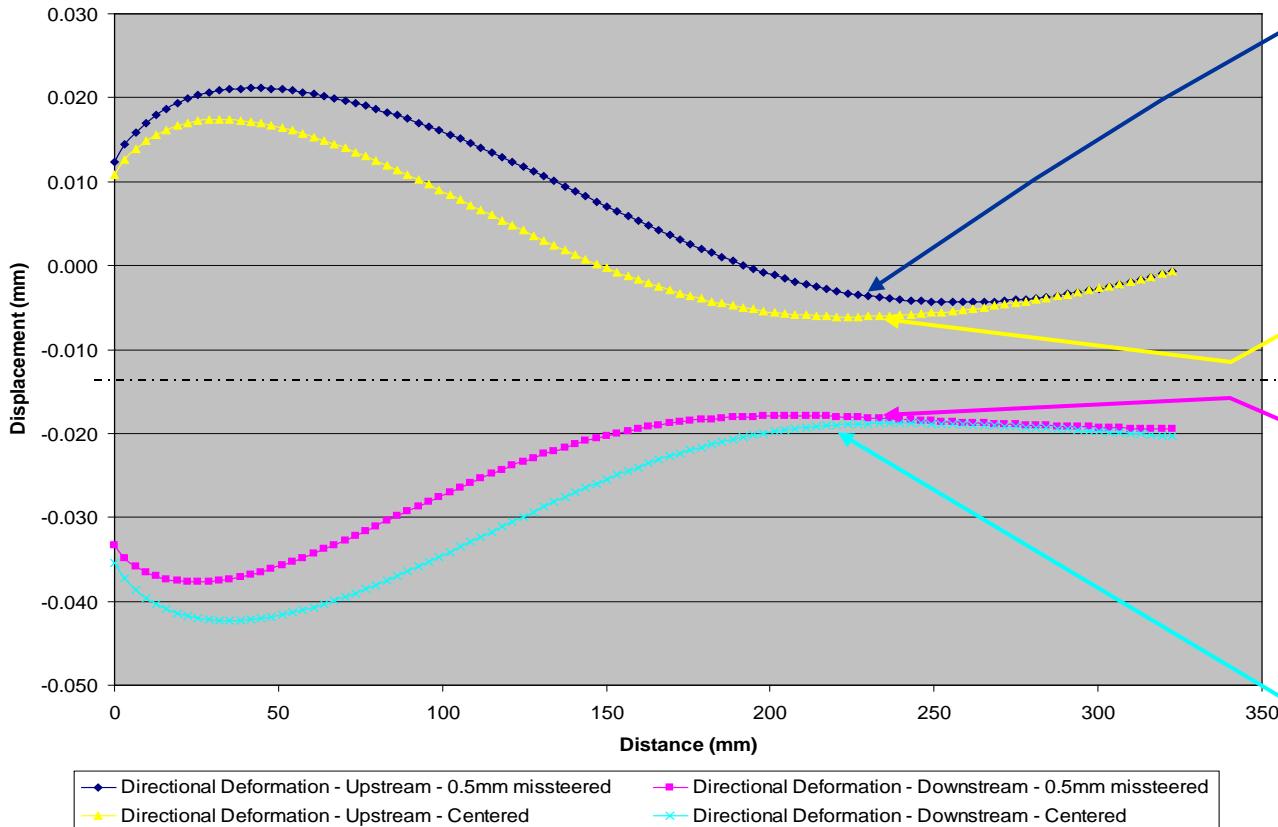

shlee@aps.anl.gov, MED/AES/APS

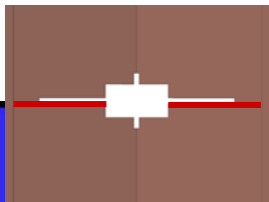



# GRID-XBPM Summary: Benefits

- (1) Use proven technology to handle the extreme power density.  
No fragile parts in the intense beam → More robust.
- (2) Use beryllium window to isolate readout detectors from active surface. No critical parts in UHV → Easier to maintain.
- (3) The limiting aperture **is** now the BPM → Simplified alignment  
→ smaller apertures can be used → Stronger S/N.
- (4) Smaller beam aperture has major impact on downstream beamlines:
  - It reduces the power load on user's optics
  - Lower beam power allows smaller collimators and shorter photon shutters → Reduces space / cost requirement; Increases speed and reliability.
  - Smaller beam uses smaller vacuum pipes → Reduces cost and improves vacuum safety.



# GRID-XBPM Summary: Problems and Solutions

- (1) Flow-induced **vibration** destabilize XBPM: Analyze the support design; make position measurements insensitive to vibration modes.
- (2) **Thermal bumps** shift XBPM active surfaces: (A) Use symmetry for cancellation; (B) Run feedback so the beam is always at center → XBPM becomes a null-detector.
- (3) Powder **diffraction** produce glitches entering and leaving the detectors: (A) X-ray filter to absorb low-energy large-angle peaks; (B) Strong cancellation due to symmetry.
- (4) **Alignments** of the parts are difficult: (1) Simplify aperture design; make less features that need to be aligned critically.
- (5) While the electric center is independent of undulator gap, the calibration factor does depend on the gap, especially when radiation pattern changes significantly in IEX and SPX: Run feedback so the beam is always at center.

# GRID-XBPM Case Study: IEX XBPM Design

## IEX XBPM Design (Target date 2011)

- Test a Undulator GRID-XBPM with one Undulator A before IEX is ready (suggested by Mohan)
- Develop XBPM for IEX elliptically polarized undulator (EMU)

## Apply lessons learned from 35-ID test:

- (1) Use independent flat plates to build GRID-XBPM. No tranches
- (2) Set exit aperture according ID properties and users' specifications
- (3) Use upstream collimator to control XBPM entrance aperture

### [Pros]

- Simple design and reduced engineering cost
- No more alignment requirement for tranches
- Not sensitive to vibrations in the vertical plane
  - mechanical support design and cooling water routing
- Allow further optimization after installation.

### [Cons]

- Less accurate mutual alignment between two plates



# GRID-XBPM for IEX-EMU: Initial Simulation

- Simulation of selected subset in K-space
  - Inner circle: 2500 eV
  - Outer circle: 400 eV
  - Vertical line: horizontal polarization
  - Horizontal line: Vertical polarization
  - Diagonal line: circularly polarized
- Calculated mono profiles at selected energy
- Calculate white beam intensity profiles
- Transmission of central cone through GRID-XBPM enables user to make informed choices: photon flux vs. beam stability.

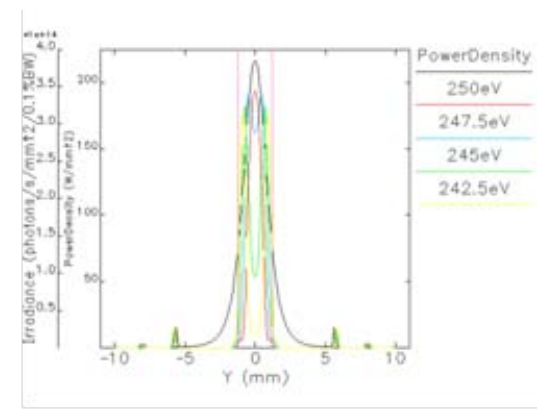
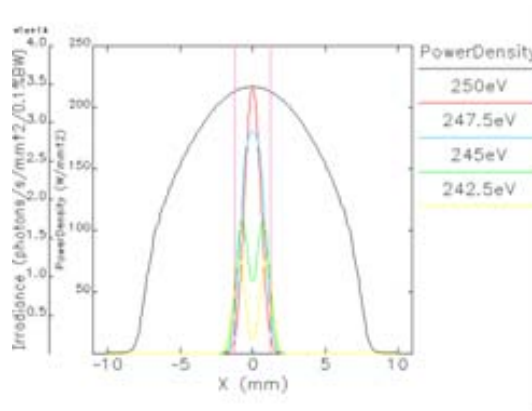
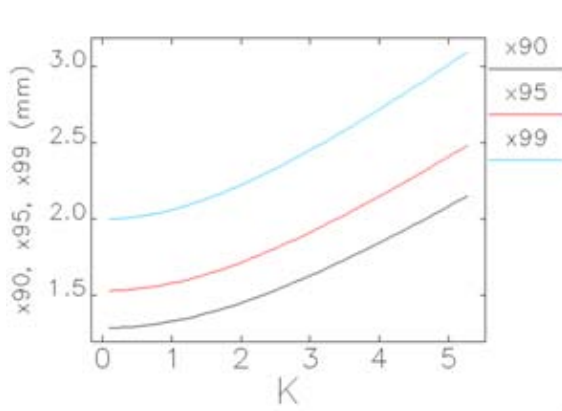
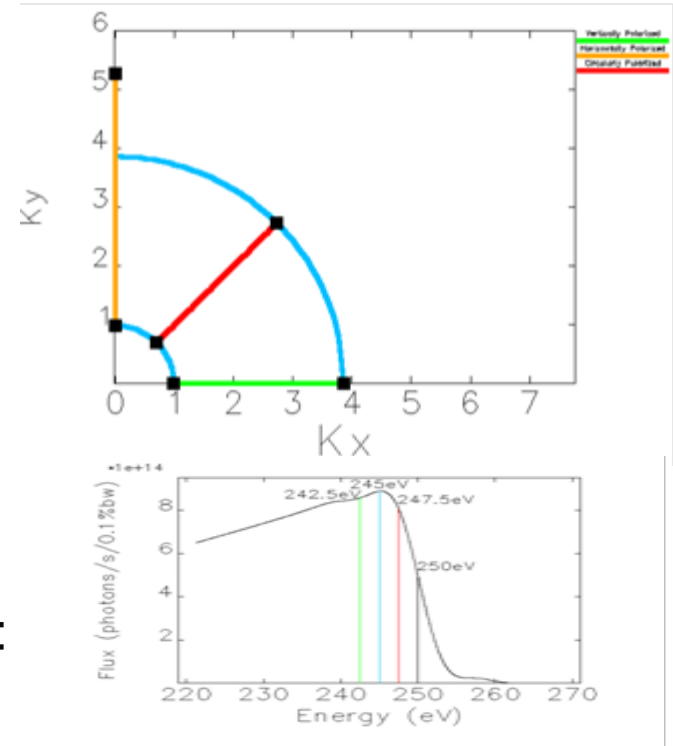

# Simulation GRID-XBPM for IEX-EMU: Circular Polarization

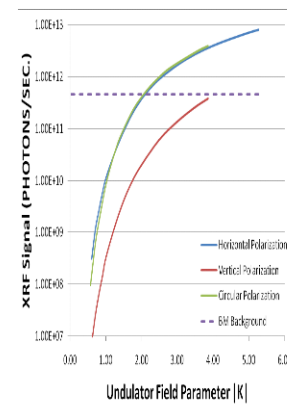
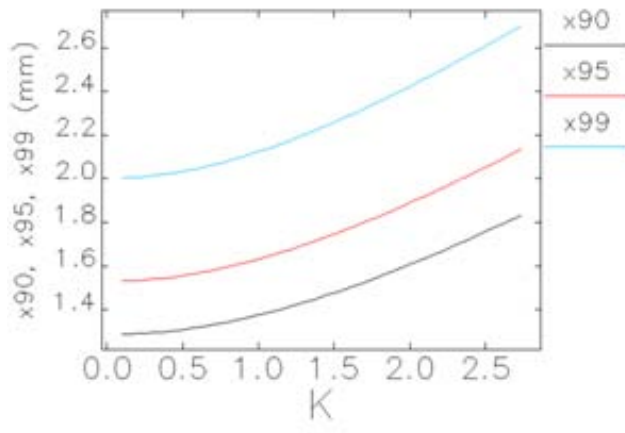
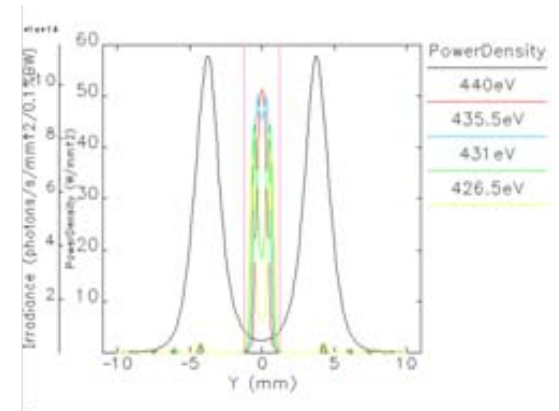
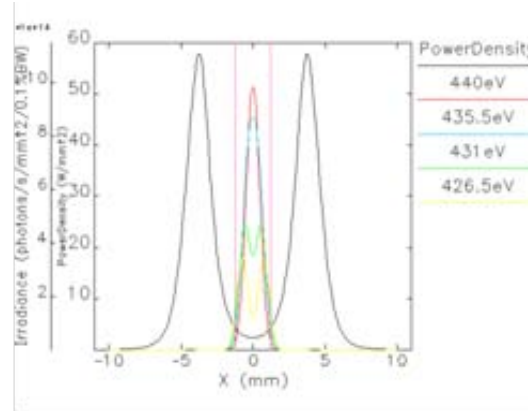
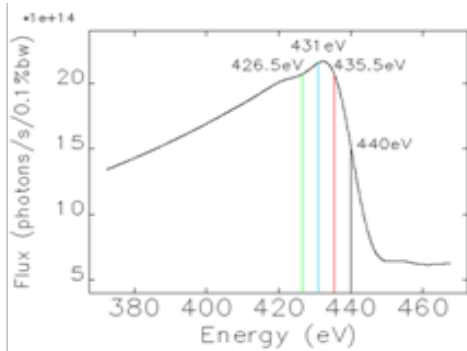

- Need to intercept up to 5% central cone flux to get good signal.
- **Surprise find:** Estimated bend magnet radiation background is much stronger than observed at S35-ID

# Summary

Grazing-incidence insertion device x-ray beam position monitor (GRID-XBPM) is a product of engineering compromises: optimized for handling undulator power, but less optimized as an XBPM. We are very optimistic for its future performance meeting the APS beam stability goals. A lot of development / optimization work are still ahead.

## Future plans

- Sector 29 test
- Refine simulation tools to perform realistic simulations
  - Validate sddsurgent
  - Implement xraylib in sdds-format
  - Realistic aperture geometry
- Detector / optics development
  - Lifetime studies, silicon vs. diamond and others
  - Suppression of bending magnet radiation background
- Develop XBPM concept for canted undulators / SPX

# Acknowledgement

**This work is the collective effort of the GRID-XBPM team**

Glenn Decker

Soon-Hong Lee

Pat Den Hartog

and myself

## **Help from many individuals**

Roger Dejus – XOP, IEX, undulator measurements

Hairong Shang – SDDS-compatible programs

Kenny Schlax – XBPM simulation (summer student)

Bob Conley and Bruce Hoster – APS machine shop



# GRID-XBPM design studies (March 2010)

