

Studies of the Heat Load on the APS Superconducting Undulator

Laura Boon

December 5, 2011

Outline

- Current work done on Superconducting Undulators
 - At ANKA
 - At APS
- Heating Sources
 - Image Currents
 - Beam Loss
 - Radiation Heating
 - Present preliminary analysis
 - Electron Cloud
 - Present future studies

Superconducting Undulator(SCU) at ANKA

- The SCU at ANKA was installed in March 2005.
- ANKA is a 2.5 GeV, 110.4 m storage ring.
- In-vacuum Undulator, 1.4 meters long
- Cooled by 3 Sumitomo cryocoolers (2 for the coils at 4K, 1 for the 10K UHV tank).
- Period length of 14 mm, peak field of 0.8 T.
- Three operating gaps: 8, 12, 16 mm full height.
 - 29 mm for injection

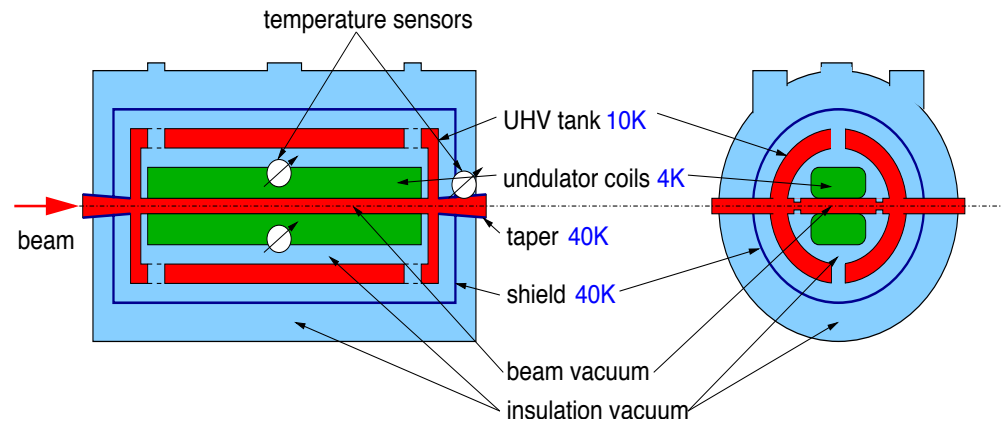

PRST-AB 10, 093202 (2007);
PRST-AB 13, 073201(2010)

SCU at ANKA

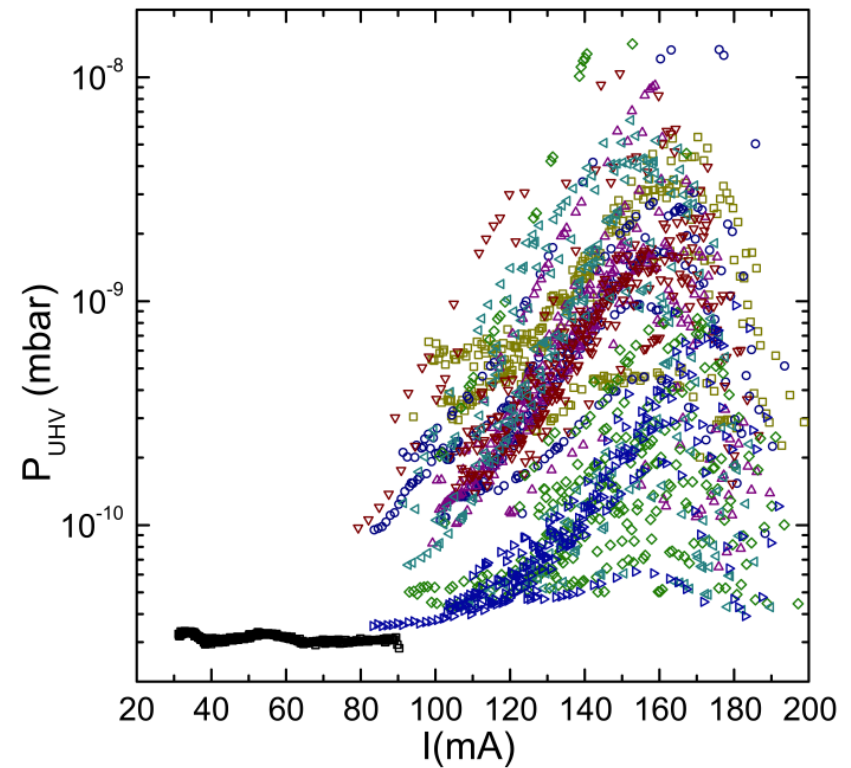
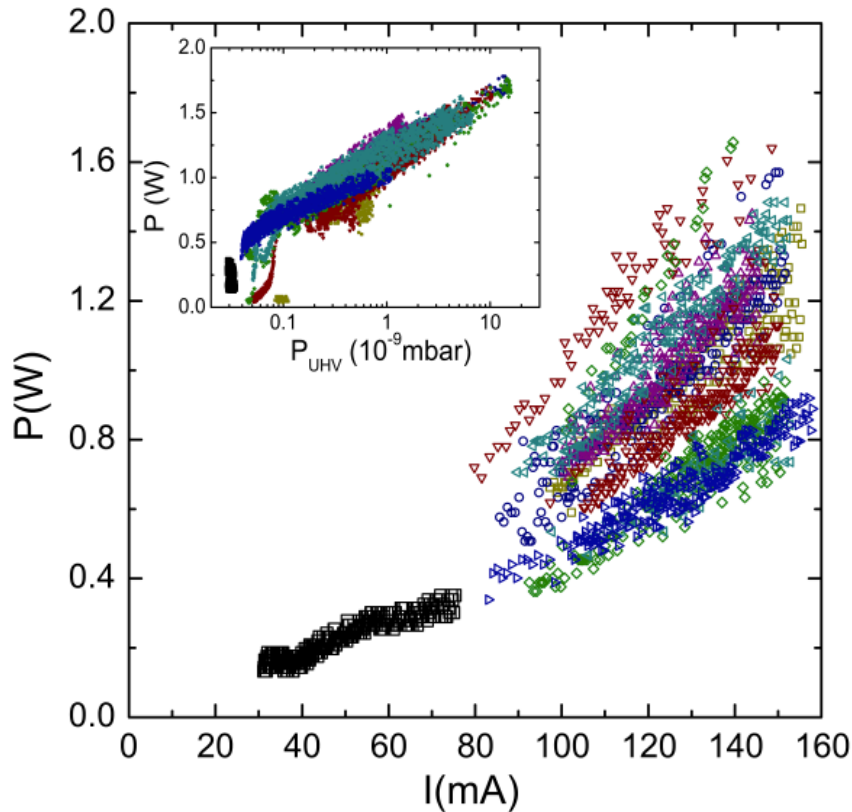

- The non-linear correlation between beam current and chamber pressure is consistent with electron cloud multipacting.
- Data was not reproducible with current electron cloud codes.

Expected Performance for the Superconducting Undulator (SCU) at APS

- Current undulators are electromagnets or hybrid permanent magnets.
 - These magnets have reached their peak fields for short period lengths.
- SCUs will allow light sources to increase the undulator peak field and therefore get higher brightness beams at high photon energy.

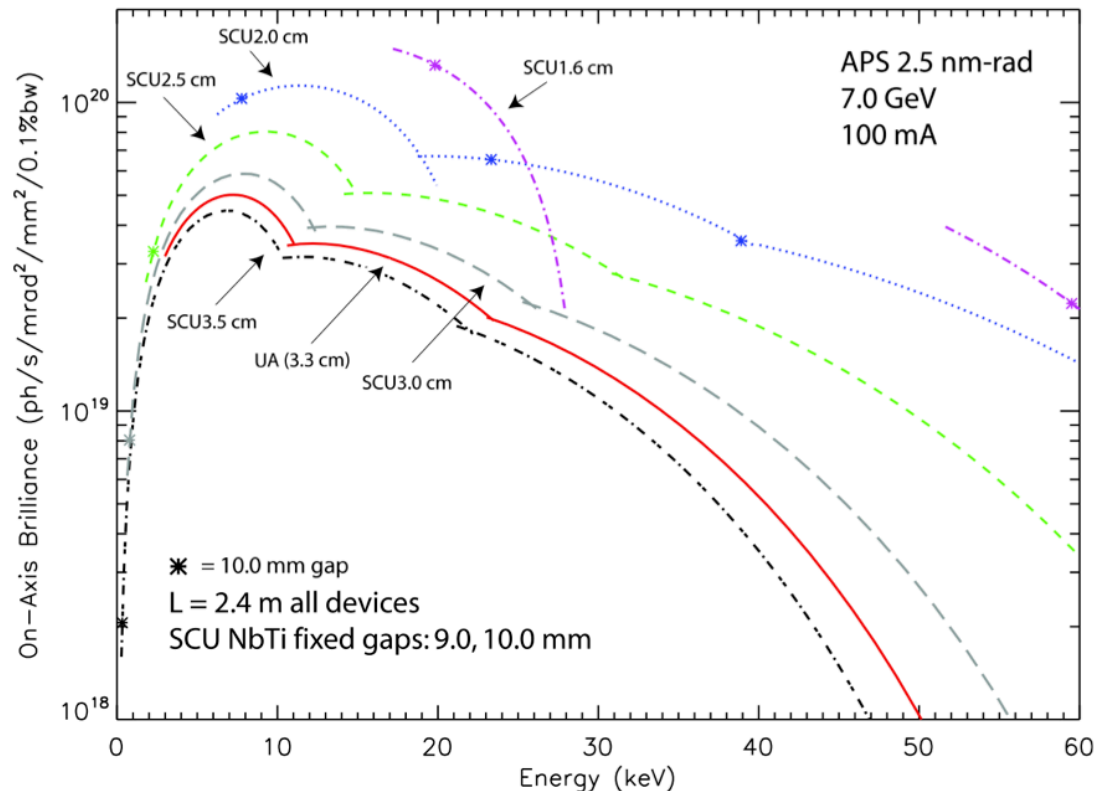

Advanced Photon Source



SCU at APS

Prototype SCU0

- Coils are 0.340 m long, 16 mm period length with 42 periods.
- Cryostat 2 m long
- Place in the second half of the straight with a hybrid permanent magnet.
- A photon absorber (PA) between the two undulators will shield the cryostat from high energy direct dipole radiation.

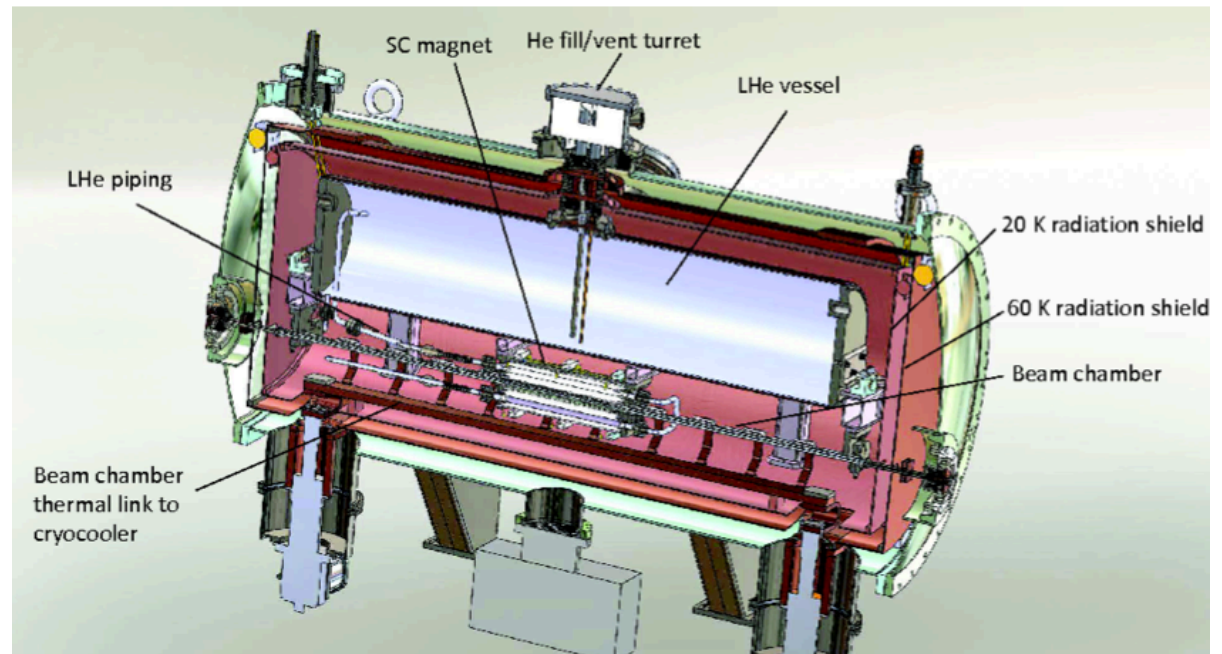

Heating Sources

- Four Heating sources are being studied for the SCU at APS
 - Image Currents or Resistance Heating
 - Beam loss in Top-up
 - Radiation Heating
 - Heating from Electron Cloud

Heat Source	Heat Load for 100mA beam (W)	Heat Load for 150mA beam (W)
Image Currents ¹	5.8	10.9
Beam Loss ²	12.6 (During top-up)	12.6 (During top-up)
Radiation Heating	*3.7	*5.6
Electron Cloud ²	**2.0	--
Total	24.1	29.1 +

¹APS_1423346; ²APS_1283081



Heating Sources- Image Currents

- Power from the resistance heating is given by:

$$P = 1.2B \left(\frac{I}{B} \right)^2 \left(\frac{\rho}{2\pi a \delta} \right) \left(\frac{R_0}{\sigma} \right)^{3/2}$$

Number of Bunches	Current per Bunch (mA) 100mA total beam	Power for 100mA(W)	Power for 150mA (W)
24 evenly spaced bunches	4.2	5.8	10.9
324 evenly spaced bunches	0.31	0.8	1.8
Hybrid mode: 56 small bunches and one 0.016A bunch	1 x 16 & 56 x 1.5	4.1	7.2

Heating Sources - Beam Injection

- When beam is injected into the storage ring some of the injected beam is lost onto the chamber walls.
- This is potentially a problem during top-up when the SCU is in use.
 - With ID4 smaller aperture beam loss is more likely to occur there.
- During Top-up
 - $C = 3$ nC are injected into the ring every minute.
 - $E = 7$ GeV Storage ring
 - $Eff = 70\%$ efficiency (30% lost on chamber walls)
 - $f =$ Injection Frequency of 2 Hz

$$P = C \times E \times \frac{1}{f} \times (1 - eff) = 12.6W$$

V. Sajaev, private communication;
APS_1283081

Heating Sources - Radiation Heating

Synrad3d

- Synrad3d is a 3D photon tracking program.
- Follows the photons as they move in the chamber.
 - Uses photon reflectivity to determine if the photon is reflected
 - All scatters are specular and elastic (for now)
 - Follows the photon until it is absorbed
- Written by David Sagan and Gerry Dugan at Cornell University
- Code in progress.

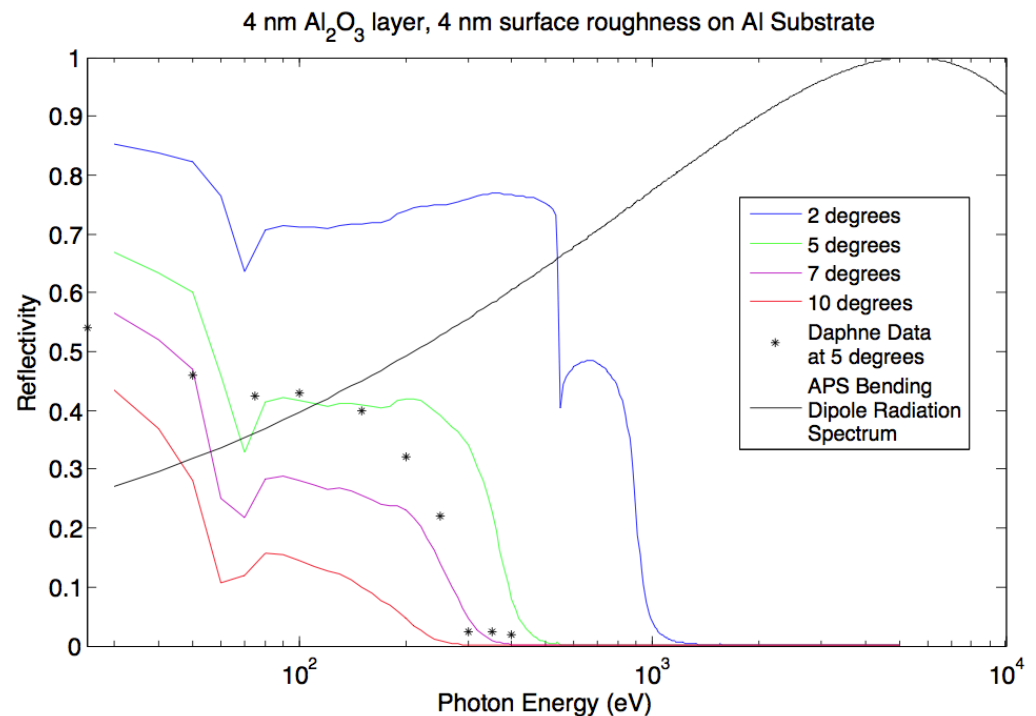

Radiation Spectra from a Bending Magnet

- Radiation spectra
 - Vertical opening angle of $1/\gamma$
 - Horizontal opening angle equal to the bend of the magnet.

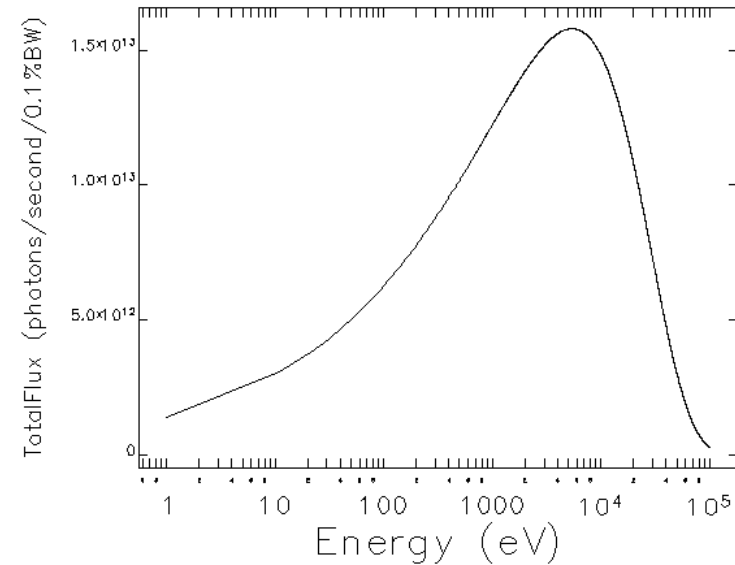
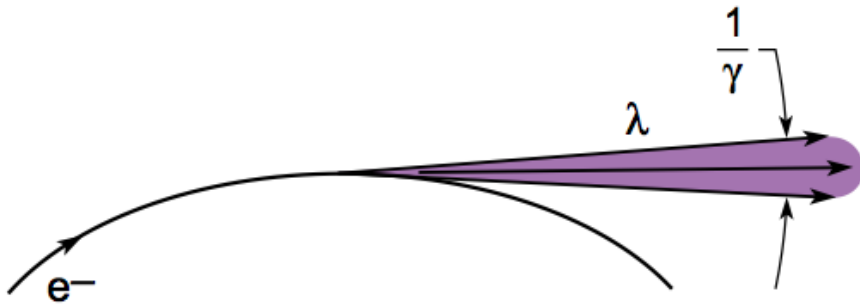

$$P[kW] = 14.07 \times L[m] E^4 [GeV] I[A] \rho^{-2} [m]$$

Heating Sources - Radiation Heating Primary Photons

$$P[kW] = 14.07 \times L[m] E^4 [GeV] I[A] \rho^{-2} [m] \quad \Theta_a = 1.9 \text{ mrad} = 2.47\% = 164 \text{ W}$$

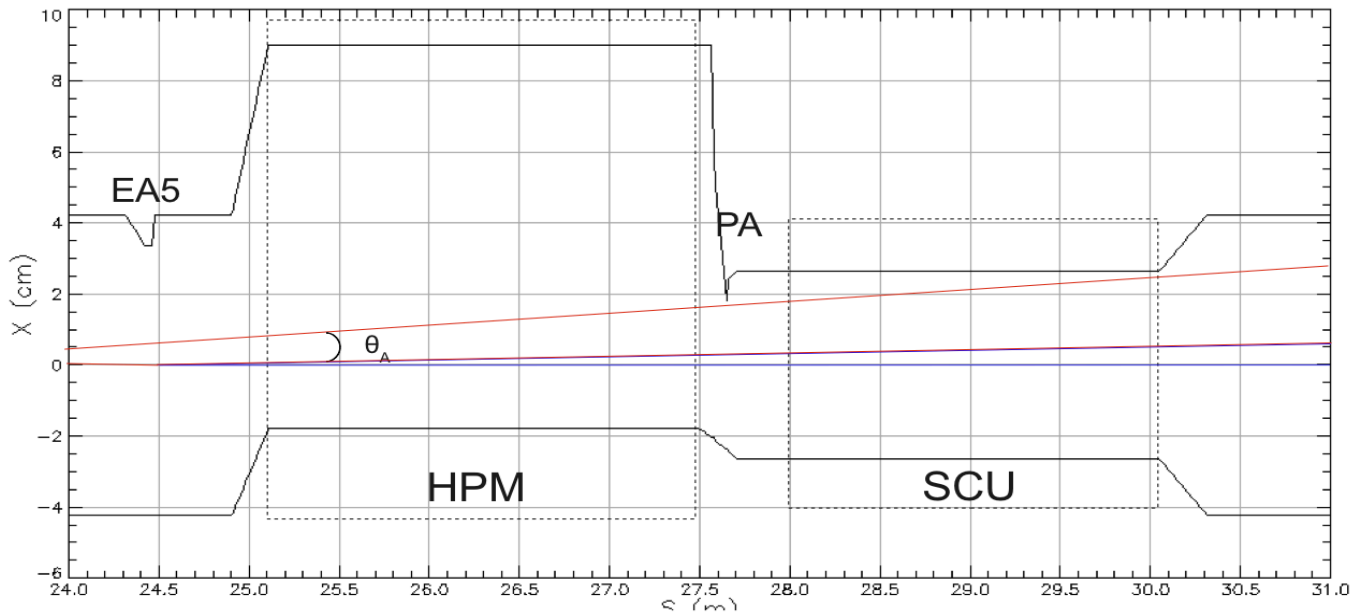

Heating Sources - Radiation Heating Primary Photons

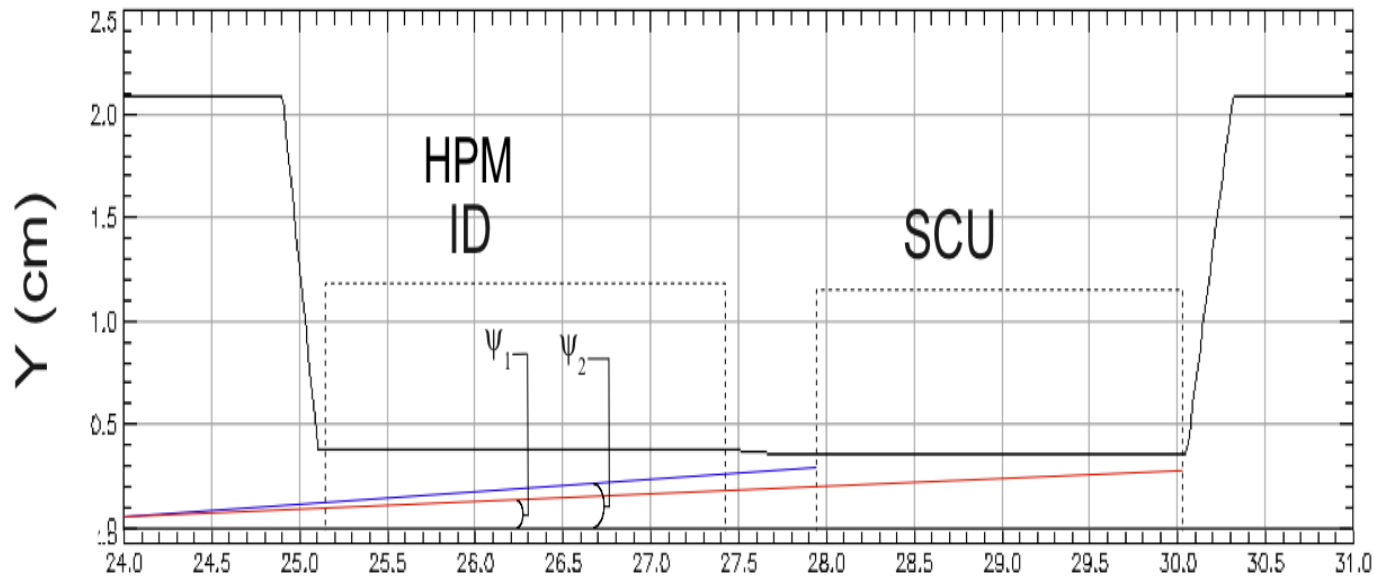

$$\int_{\psi_2}^{\infty} - \int_{\psi_1}^{\infty}$$

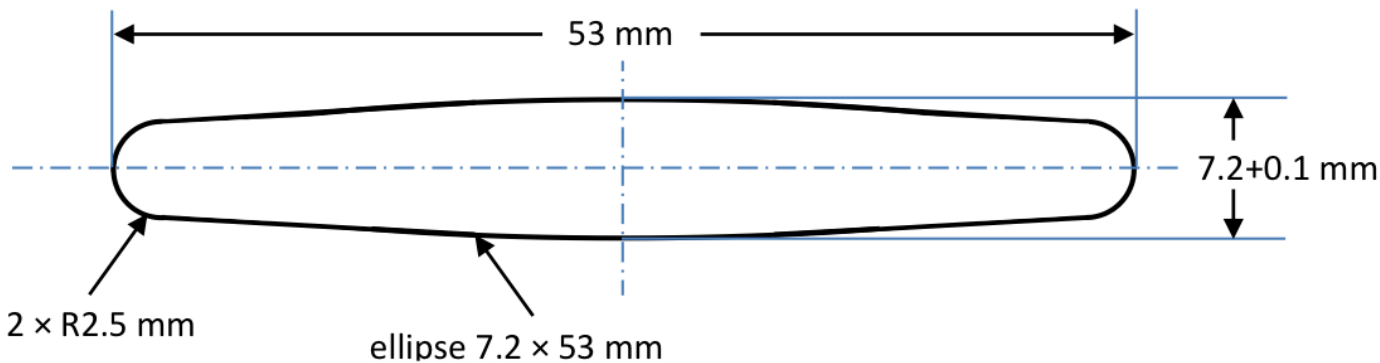

$$0.25\% = 0.42W$$

Heating Sources - Radiation Heating

Primary Photons

- Using Synrad3d without reflections the power absorbed on the SCU can be calculated using:

$$P_{sim} = E_{TOT} \times Int \times I$$

- E_{TOT} = Total energy of the photons absorbed
- Int = Intensity
- I = Current

	Calculation (W)	Simulation (W)
Main Bend	0.240	0.288
Mini-Bend	0.0017	0.0016
Total	0.242	0.290

Absorbed Photon Spectrum with no reflections

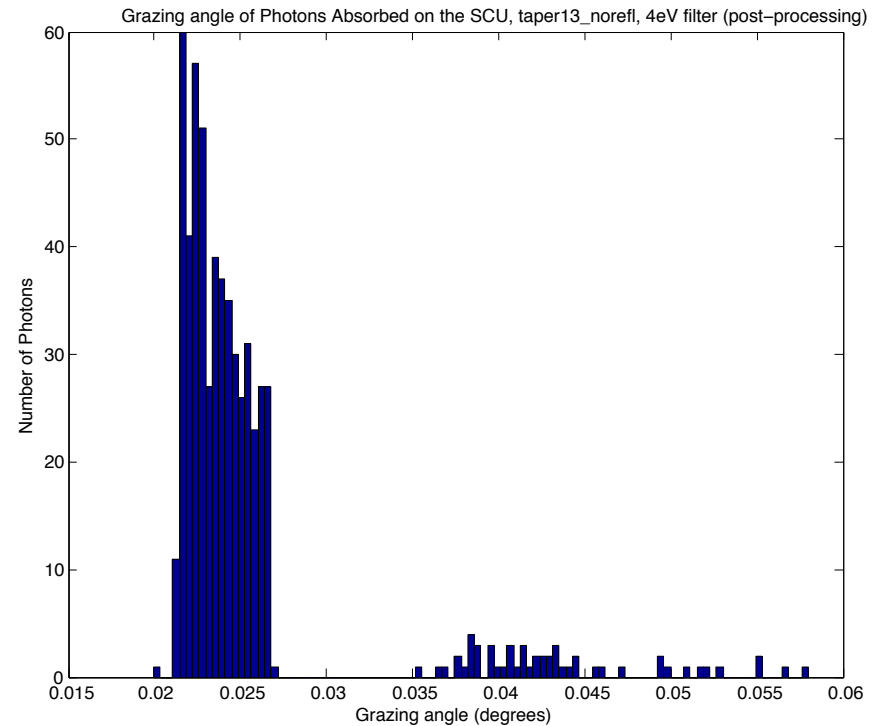
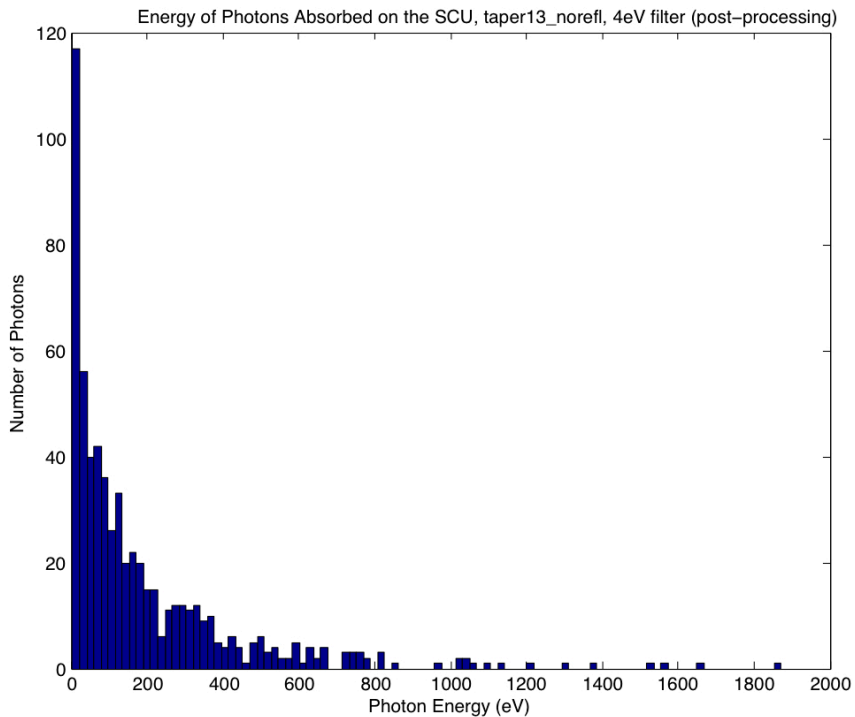

- The energy distribution of photons absorbed on the SCU, when there are no reflections
- Highest flux is low energy photons, between 4 and 700eV.
- The grazing angle of absorbed photons is dependent on the distance between the photon source and the SCU.

Radiation Heating Horizontal Beam Steering

- Off-axis beam through the bending magnets changes the trajectory of the radiation fan.
- 1W line is where the radiation fan just touches the wall.
- Need to compute the power density.

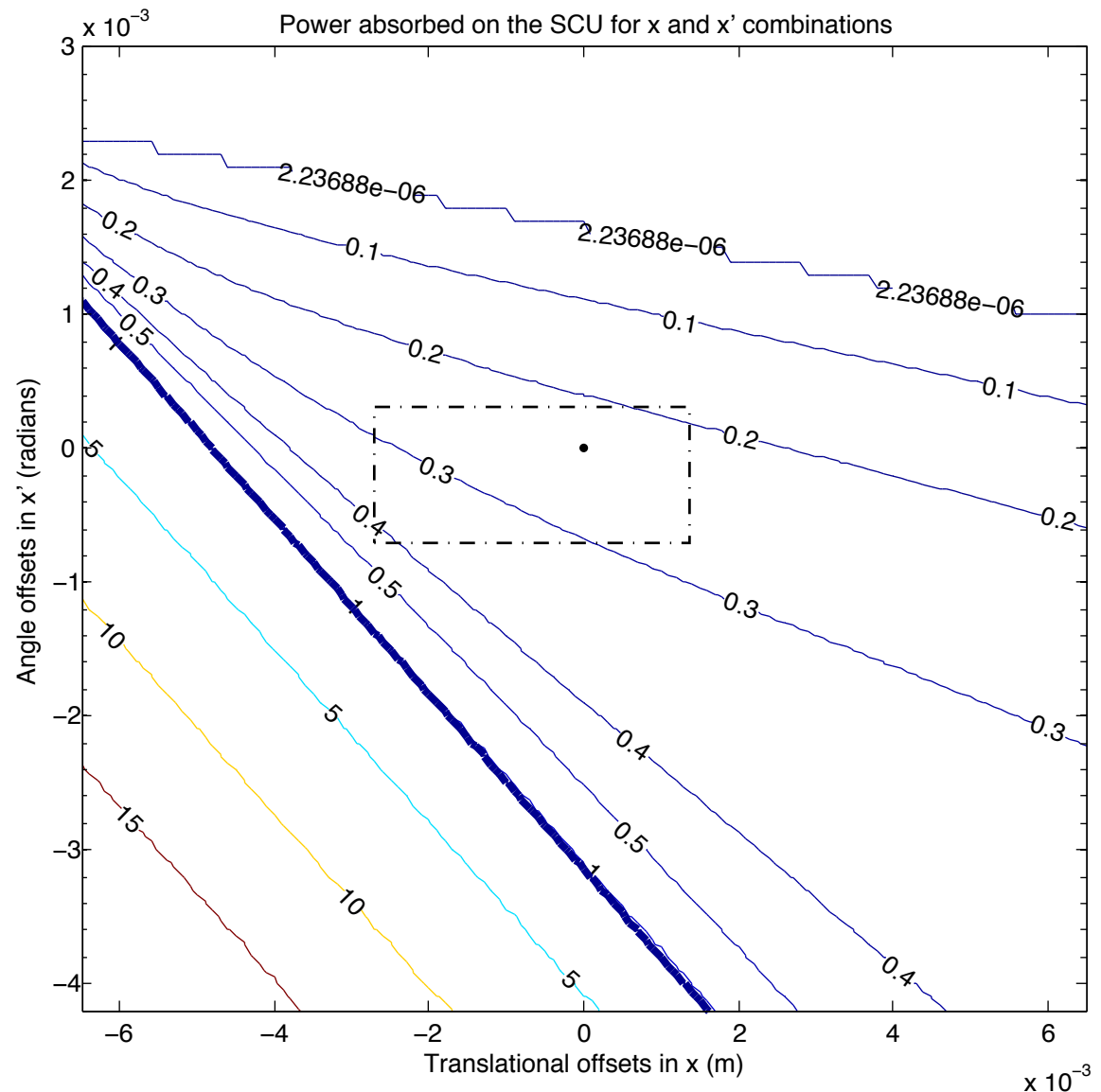

Vertical Steering

- The vertical steering breaks symmetry, and more power is absorbed on the top or bottom of the chamber.
- Need to combine x-y steering through the main bending magnet.
- Need a way to control vertical steering

$$P_{Tot} = \frac{P_{Top}}{2} + \frac{P_{Bottom}}{2}$$

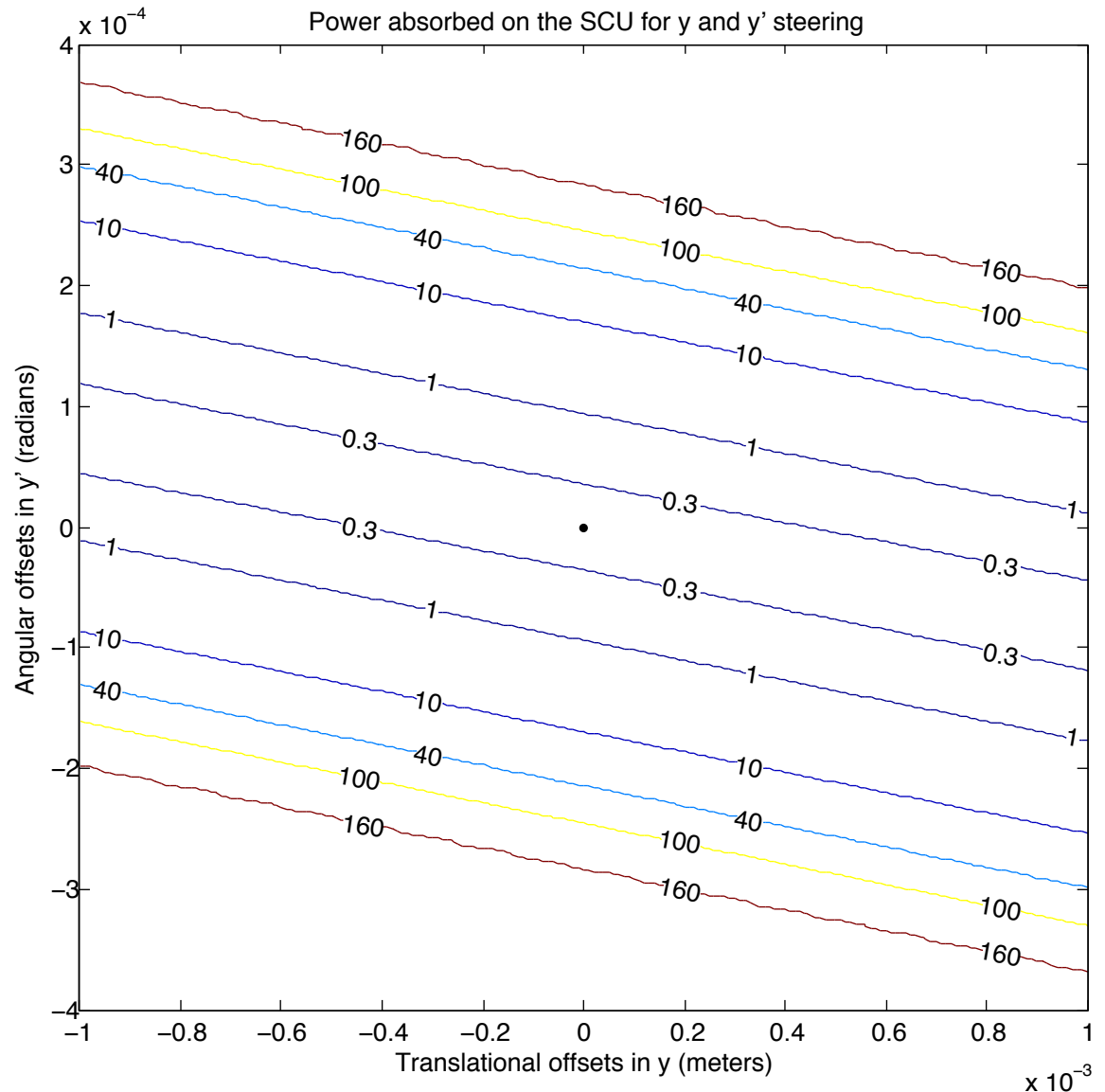

Heating Sources - Radiation Heating Photon Absorber

- Used to shield the cryostat from direct radiation.
- Designed to absorb 1kW of power.

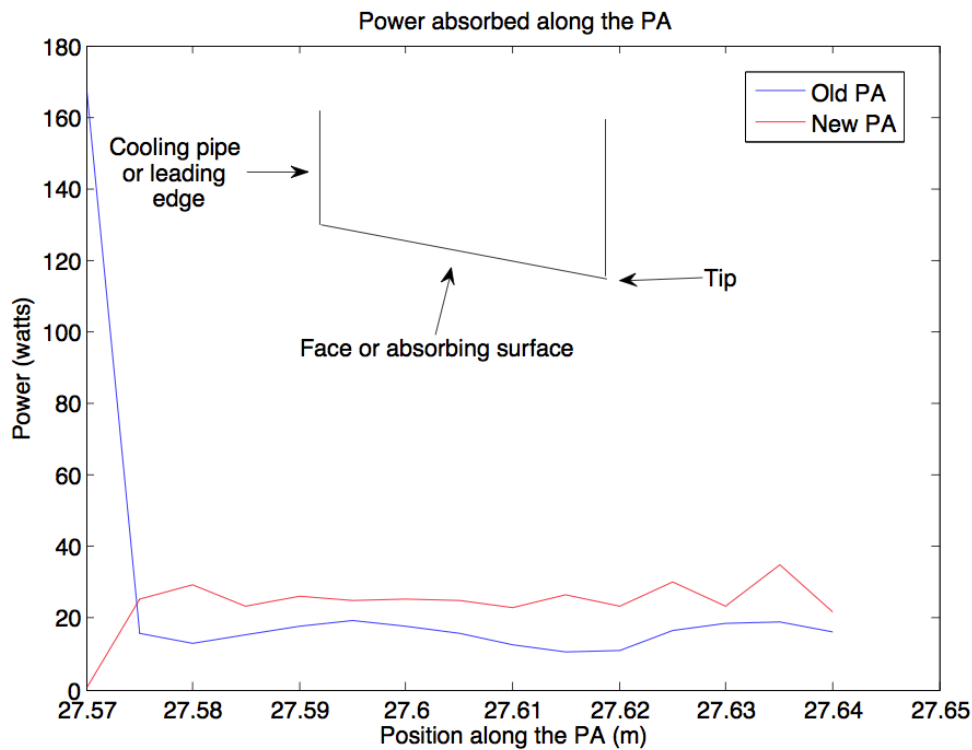
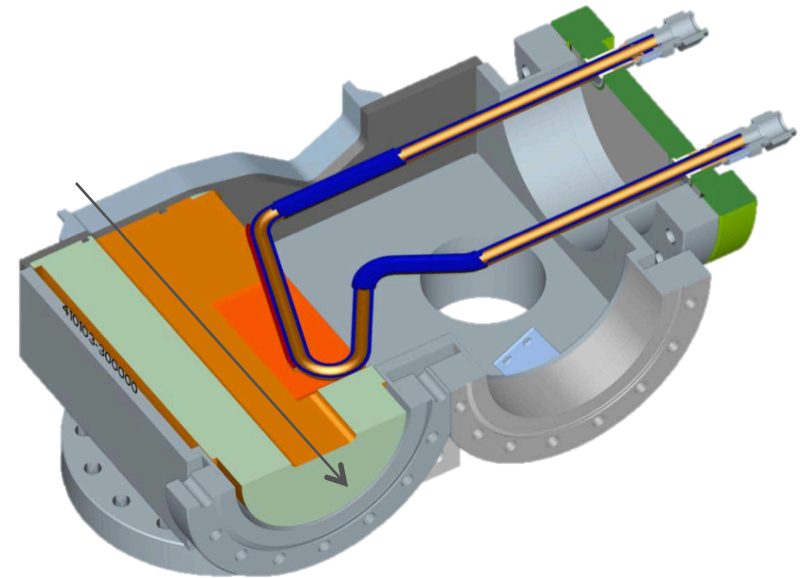

PA	Angle	Total power absorbed per 100mA
Old	19 degrees	439.6 W
New	30 degrees	456.0 W

Reflections off the Photon Absorber

- Photons can reflect off the PA assuming a specular and elastic scatter.
- None of these photons are absorbed in the SCU
- Flux along the leading edge is from reflected photons

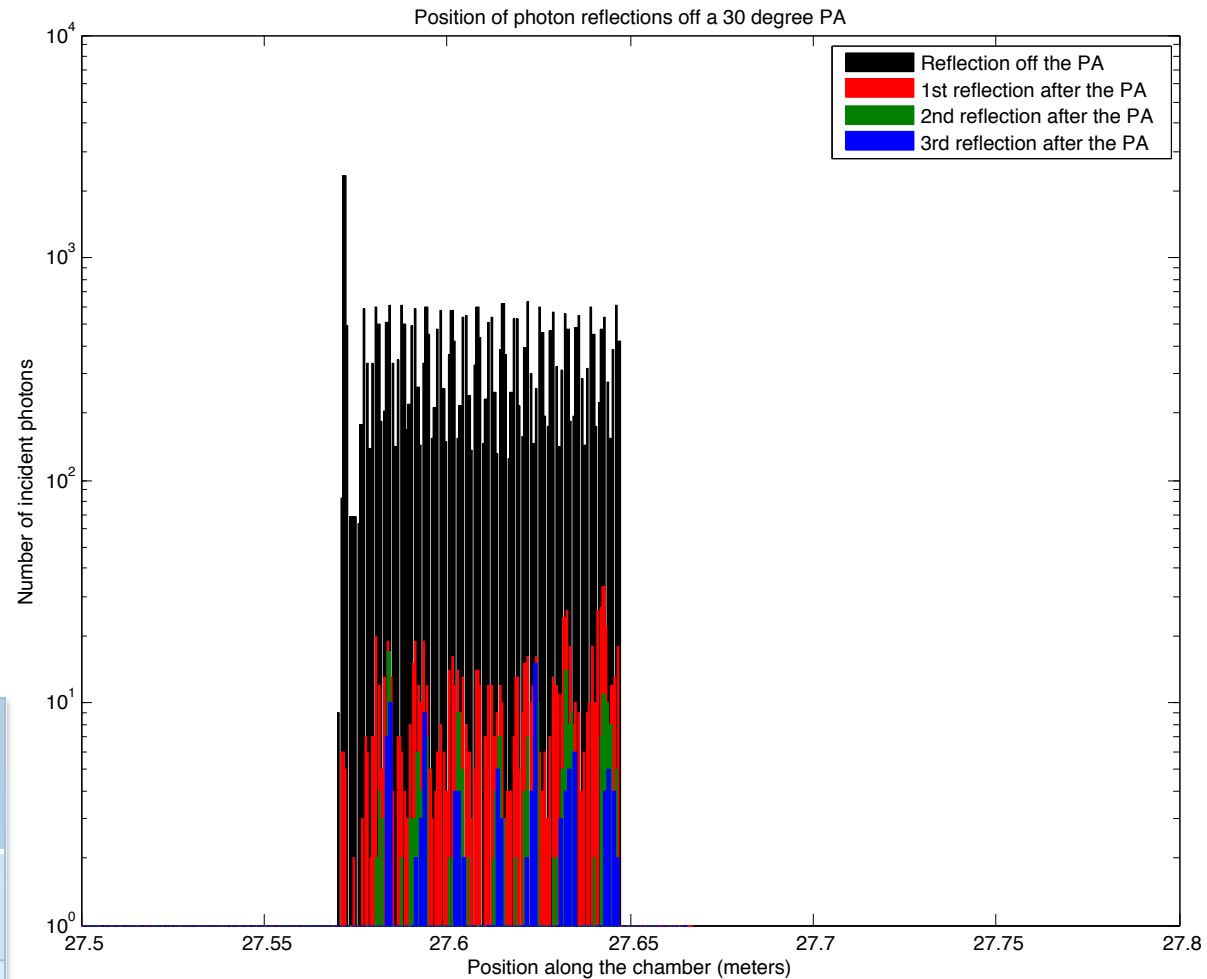

PA	Percent of photons absorbed on PA	Heat on SCU from PA
Old	97.5%	0 W
New	97.3%	0 W

Absorbed Photon Spectrum allowing reflections

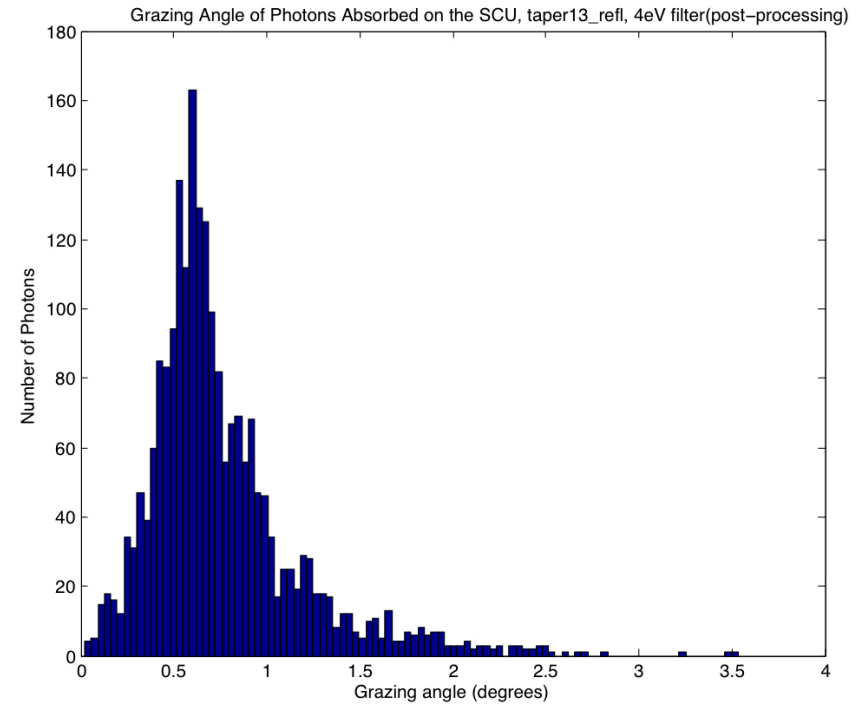
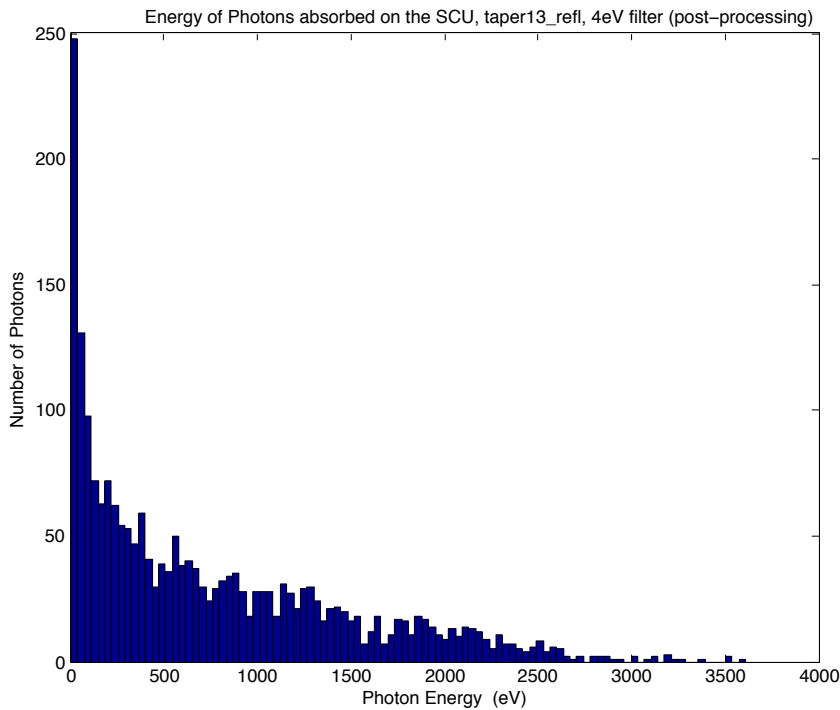

- The energy spectrum increases at higher photon energy since these photons can now reflect into the SCU

- The grazing angle of the absorbed photons has the highest flux at 0.6 degrees.

Heating Sources - Radiation Heating Photon Scattering

- Currently Synrad3d assumes a smooth vacuum chamber wall. Our studies* at APS showed that extruded Al chambers have a surface roughness of 75-400nm rms.
- Effects the reflectivity of low energy photons (10 eV to 1 keV).
- Updates to Synrad3d:
 - Assumes $\sigma/\lambda \gg 1$
 - Diffuse scattering dominates
 - Still being debugged and validated

*Analysis of the APS chambers done by L. Assoufid

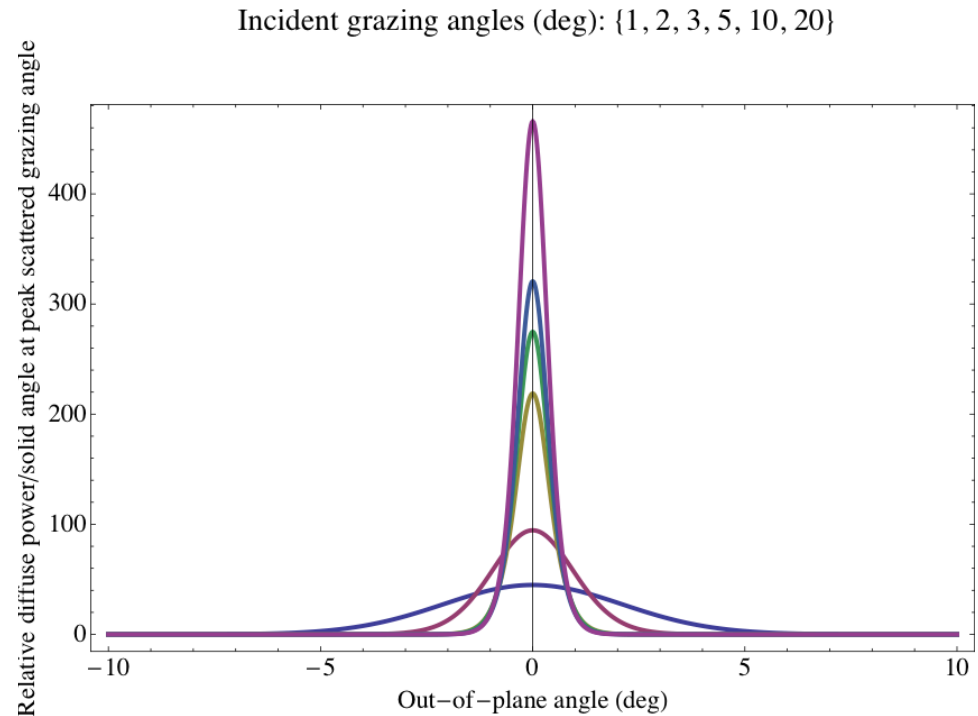

Summary- Radiation Heating

- Power absorbed from direct photons ~ 0.29 W from simulations
- Power absorbed from reflected photons ~ 3.7 W from simulations
 - This assumes specular and elastic scatters.
- Analytical calculations of beam steering showed:
 - Horizontal steering will not create a large heat load on the SCU cryostat, but the stability of this needs to be determined.
 - Vertical steering could create problem on the cryostat, studies need to be done to determine what the vertically allowed steering is, and how to limit it.
 - Still need to calculate combined horizontal and vertical steering through the main bend.
 - Separate and combined steering through the mini-bend.
 - Calculate the power density.
- Photon absorber analysis showed that the larger angle will keep direct radiation off the leading edge, though both designs successfully shield the SCU from reflected photons
- Surface roughness studies
 - It has already been shown that the chamber is rough, but studies still need to be done to determine how that roughness effects the reflectivity
 - Need to validate the updated Synrad3d model

Heating Sources - Electron Cloud

- Electron cloud can heat the chamber when low energy electrons are accelerated into the vacuum chamber by the beam
- Primary electrons are created from three processes:
 - Photoemission
 - Secondary electron
 - Fluorescence
- Secondary electrons are created from free electrons being accelerated into the chamber wall.
 - Amount of electrons created is dependent on the material and energy of the incident electron.

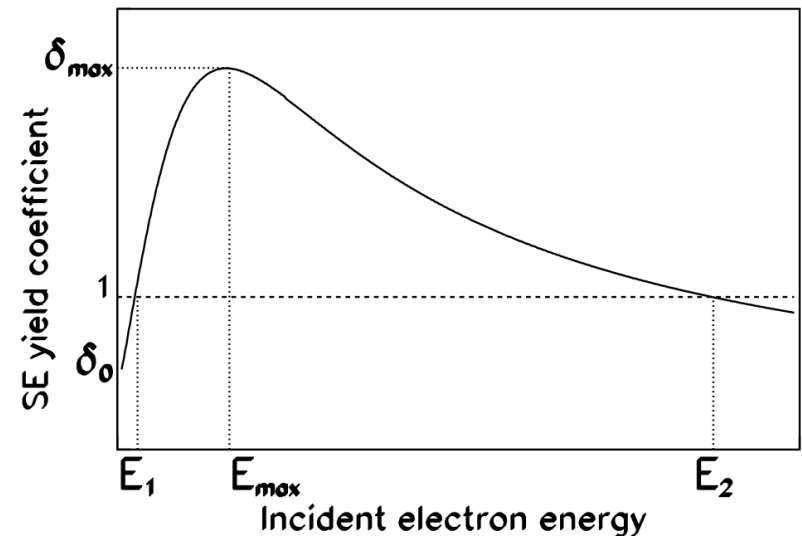

Heating Sources - Multipacting with Electron Cloud: Positron Beam

- Beam-induced multipacting is a resonance that can amplify the electron cloud density.
- Maximum signal in RFA at APS: 7-bucket spacing (19.9 ns), std chamber.
- EC codes (posint) reproduce data well when realistic secondary electron parameters used; not very sensitive to photoemission model.

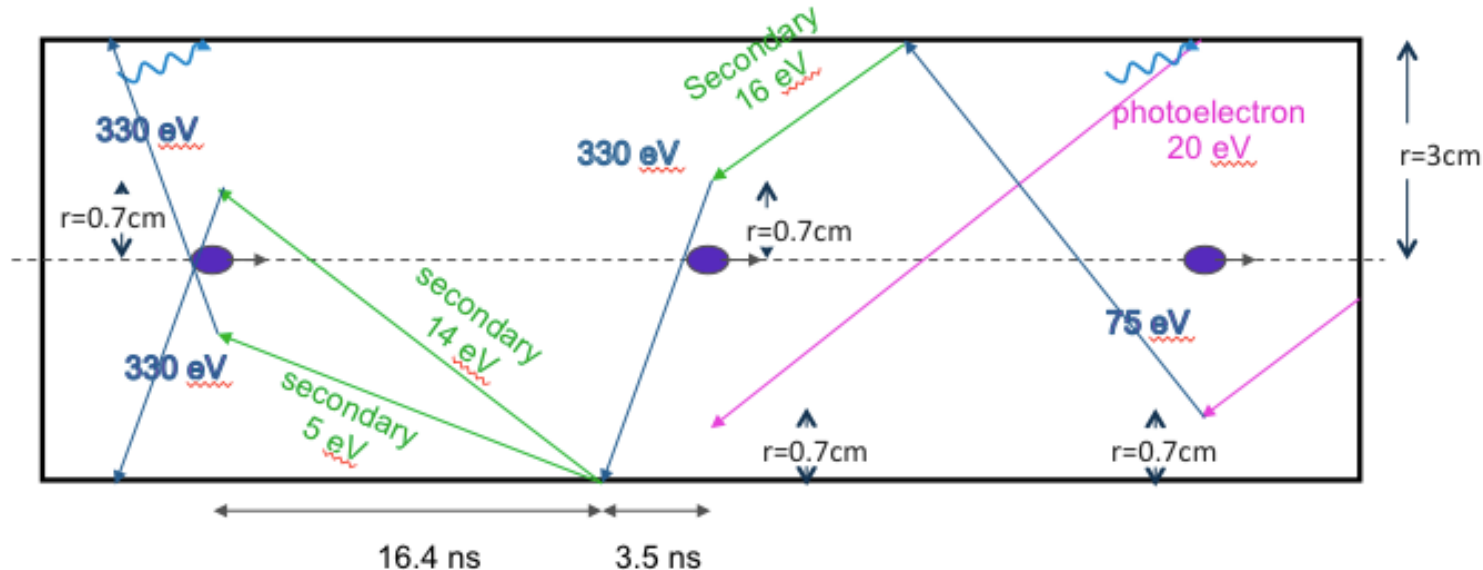
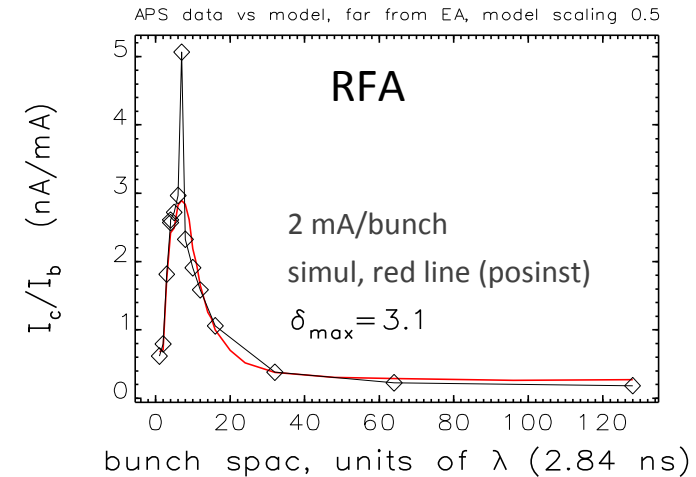

Heating Sources - Multipacting with Electron Cloud: Electron Beam

- Multipacting is a weaker effect in electron machines, but not absent – it could create heating as seen at ANKA.
- Maximum signal in RFA at APS: 11-bucket spacing (31.2 ns), std chamber.
- EC codes do not reproduce data well; we believe that the photoemission model needs to be improved.

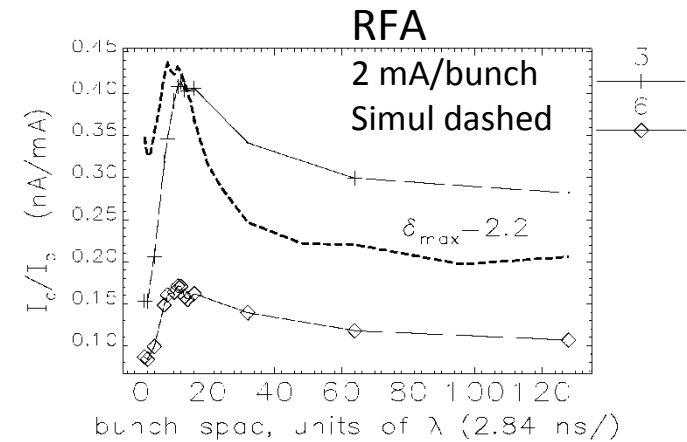

K. Harkay et al. PAC.

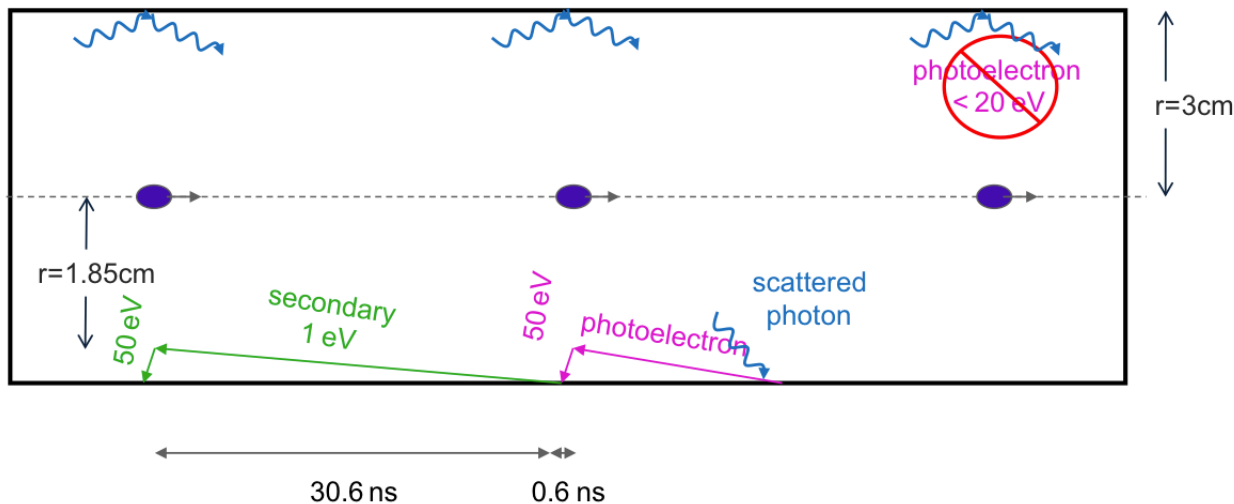

Heating Sources - Electron Cloud in SCU0

- Possible multipacting resonance using 2mA/bunch, 2-bucket spacing (5.7 ns), and 1-cm average chamber radius is shown.
- Example is not modeled in posinst since photoelectron energy assumed to be very small.
- Impulse kick approximation ($\Delta K = \Delta p^2 / 2m_e$) used for figure, but not strictly valid since bunch length (~ 1 cm) is of order of chamber aperture. Need a code like posinst to compute kicks from slices (average energy on wall is \sim keV in prelim result).

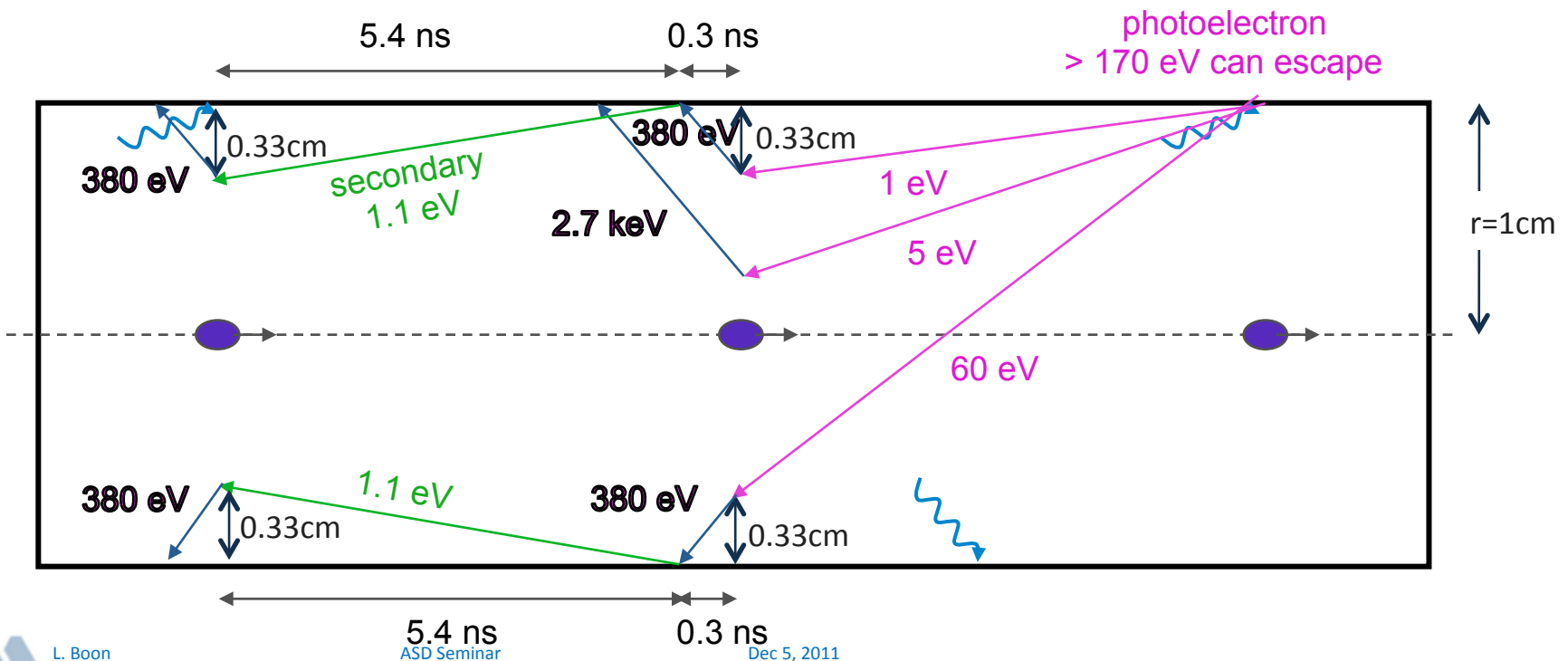

Electron Cloud Measurement

- The photoemission yields are not fully understood for the conditions of the SCU and needs to be studied to better understand electron cloud generation.
 - This includes the true primary electrons and the secondary emission from incident absorbed photons
- The goal is to measure the QE and photoemission spectrum for cold aluminum to use as the input to electron cloud codes such as ELOUD.
 - This includes the angle and surface roughness dependence of the QE
- Electron cloud is a possible heat source that needs to be studied.
- Use the results from Synrad3d and radiation heating as inputs to the generation of electron clouds in the cryostat.

Measurement of Photoemission

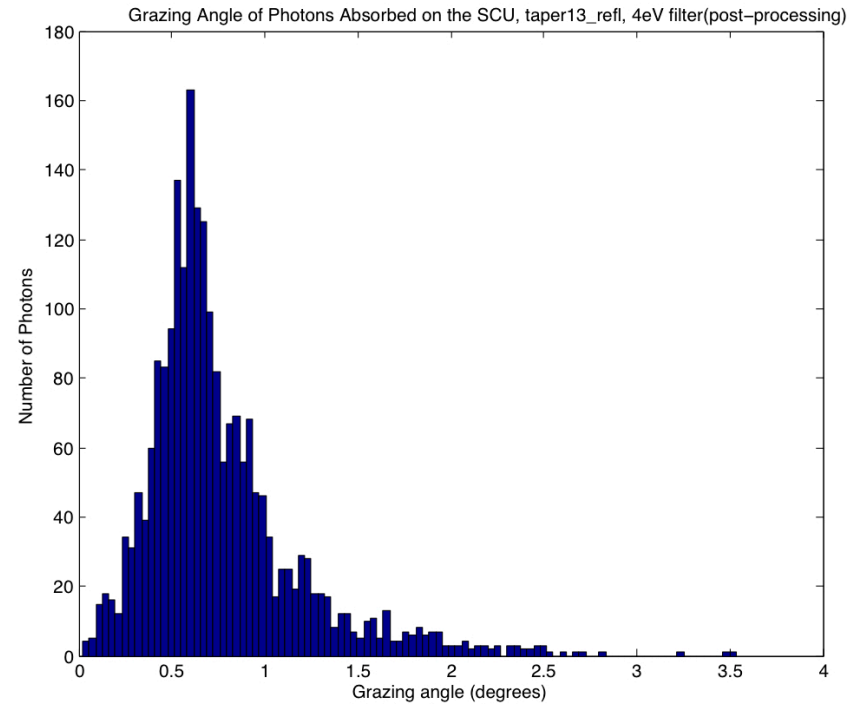
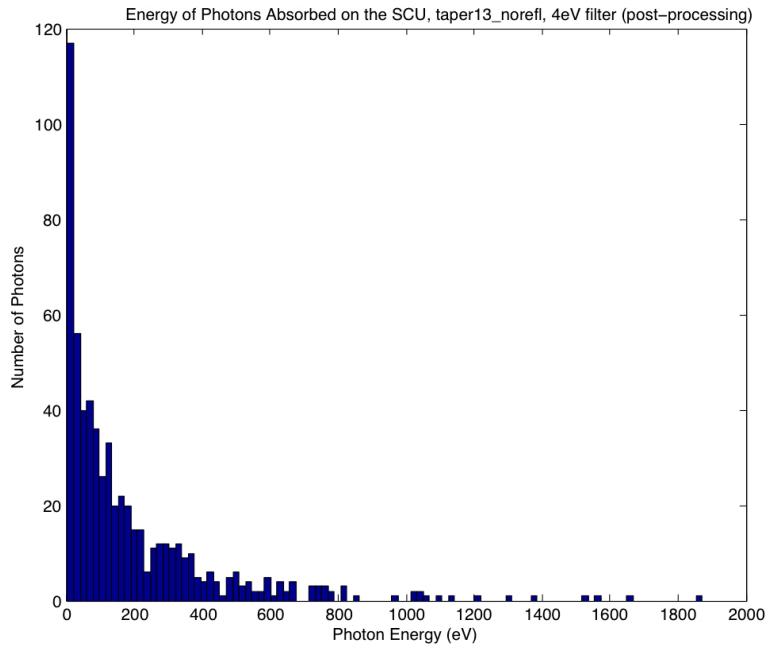

- The energy of the photons that are absorbed on the SCU between 4-700eV.
- For the QE study we will need VUV

- The grazing angle of the absorbed photons has the highest flux at 0.6 degrees.

Summary of Electron Cloud Heating

- Current Electron cloud codes are not able to reproduce the data from electron beams. One reason may be that in electron machines photoemission dominates.
- Electron cloud could be a heat source on the cryostat based on data from ANKA, and needs to be further studied and possibly mitigated for SCU0.

Questions?