

# Final Design and Testing of the DCS Pink Beam Stop

**Jeff Collins, Jeremy Nudell, and Dana Capatina**

Mechanical Engineering & Design Group  
Advanced Photon Source, AES Division

Accelerator Systems Division Technical Seminar  
Jan. 14, 2015

# Outline:

- DCS Pink Beam Stop Requirements
- Brief Discussion of Pink Beam Stop Mechanical Design
- Pink Beam Stop Experimental Program
- Conclusions



# DCS Pink Beam Stop Requirements:

## Requirements:

- The Pink Beam Stop must be able to stop the beam under the worst-case DCS beam condition
- The Pink Beam Stop must satisfy all personnel safety system (PSS) requirements
  - The Pink Beam Stop must protect the downstream lead shielding under all conditions
  - The size of the beam strike area (229 mm W x 305 mm H) is defined by ray tracing

## Worst-Case DCS Beam Conditions

Slits	Percent transm.	Power (W)	H Im. size (um)	V Im. size (um)	W/mm <sup>2</sup>	W/mm	Im.loc. (m) / station
B	66.41%	169.3	61.1	26.3	105367.9	968.5	70.95 D
B	66.41%	169.3	183.8	69.4	13281.6	334.4	79.88 E
C	100.00%	255.0	250.7	39.3	25899.4	439.7	70.95 D
C	100.00%	255.0	753.8	103.6	3264.6	148.7	79.88 E
B	31.81%	81.1	57.7	31.8	44194.7	453.0	79.88 E
C	100.00%	255.0	158.2	35.5	45429.2	658.2	79.88 E
<b>B pink stop data, for comparison</b>							
		338.8	232.1	18.5	78903.6	676.0	48.8 B

## Desirable Operating Features:

- Detection of beam presence
- Ability of measure the total power of the beam

→ Conventional design criteria limits ( $T_{\max} < 300^{\circ}\text{C}$ ) are impractical because a grazing incidence angle  $< 0.5^{\circ}$  would be required, and consequently, the beam stop length would be  $> 5$  m.

# DCS Pink Beam Stop Mechanical Design:

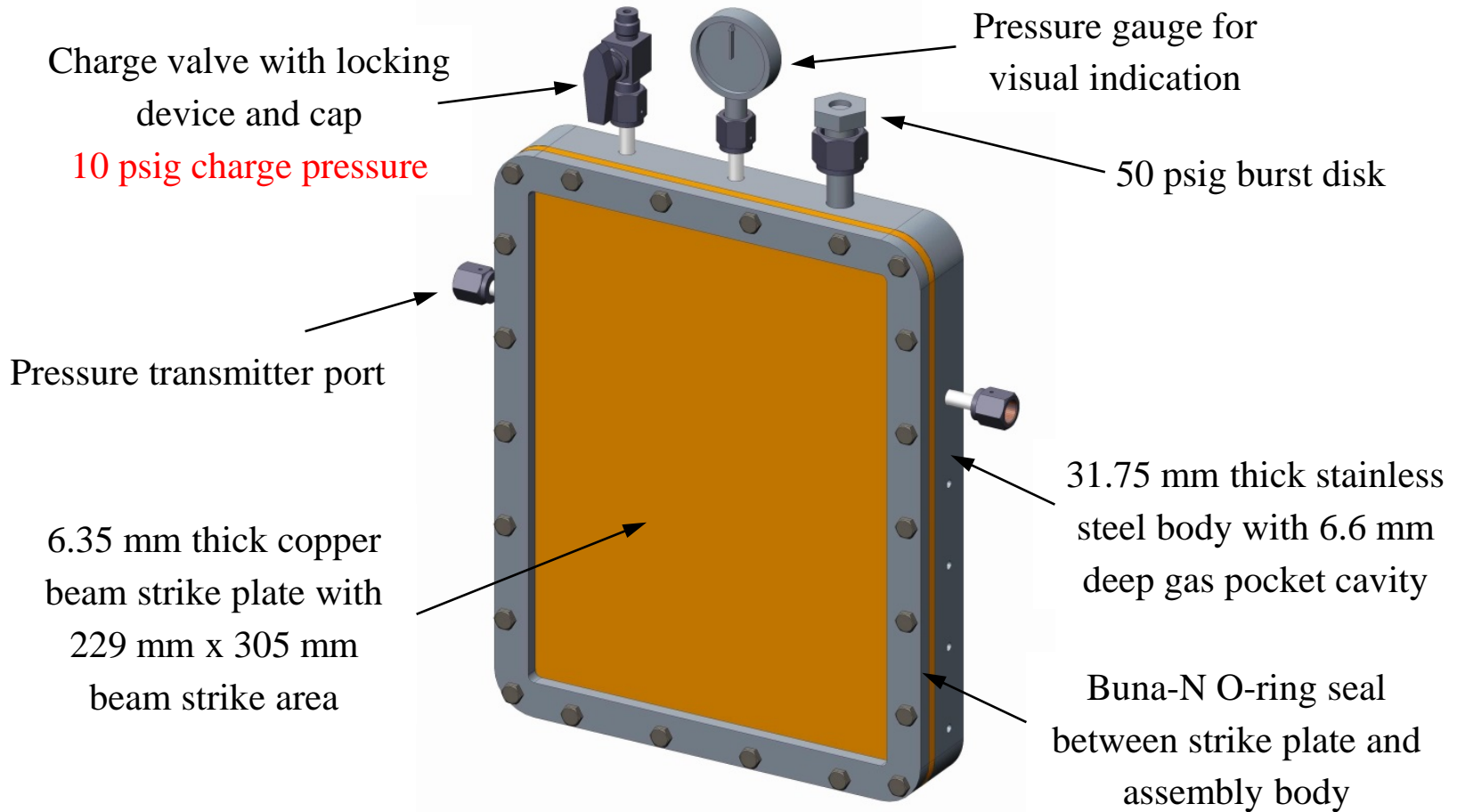

- All fittings are welded into the assembly and use Swagelok® VCR all-metal face seal gaskets
- A cavity 12.95 mm deep is milled into the assembly behind the beam strike plate
- A 6.35 mm thick copper plate is press fit into the bottom of the cavity leaving 6.6 mm deep gas volume space behind the beam strike plate

# Pink Beam Stop Installations:

E Station only

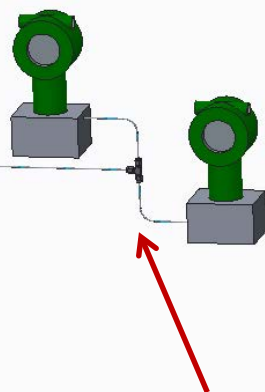
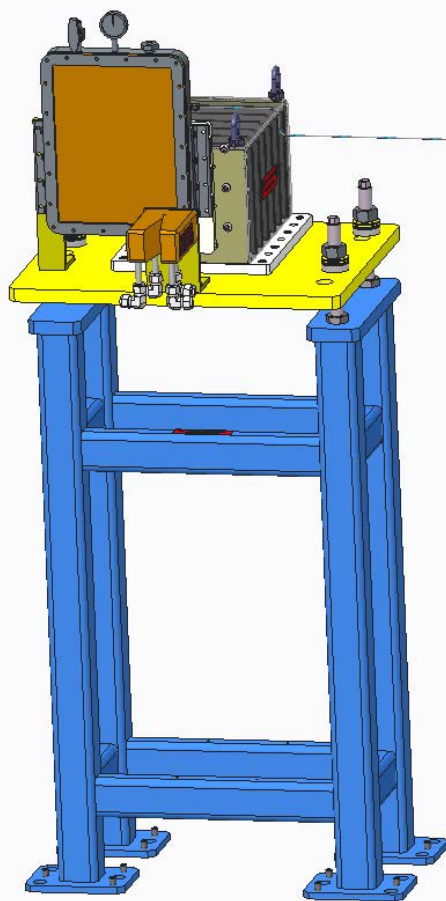

Yokogawa differential pressure transmitters for chains A & B PSS system,  
8.75 psid & 11.5 psid set points  
4 mA = 8 psid  
20 mA = 12 psid

B, C, D Stations

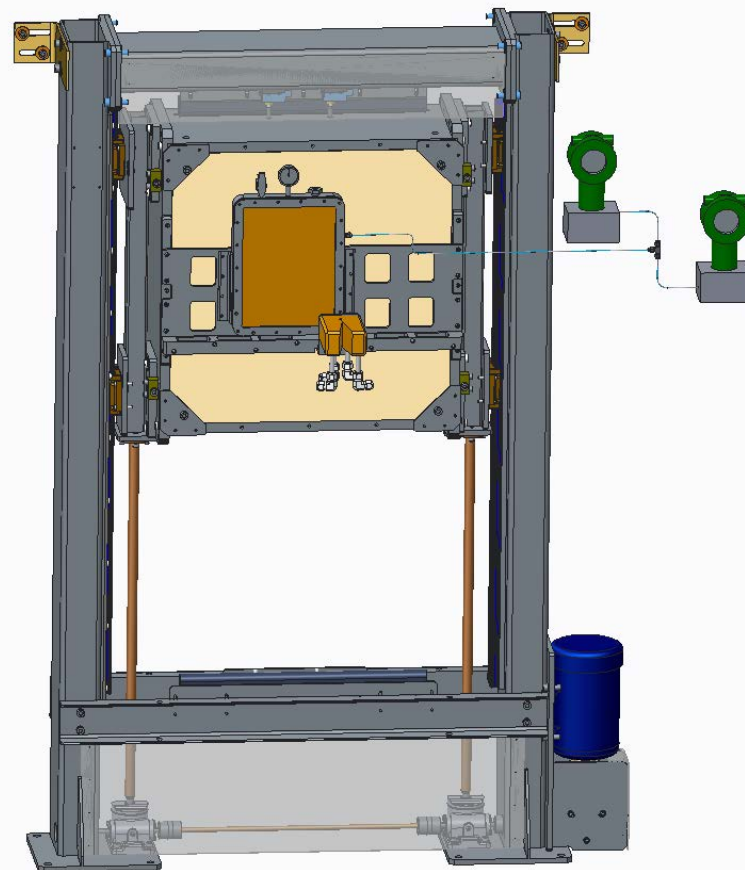

Mounted on a Fixed Table

Mounted on a Movable Lead Stop

- Gas volume of the Pink Beam Stop assembly is  $\sim 30 \text{ in}^3$
- Gas volume of the differential pressure transmitters & tubing is  $\sim 2 \text{ in}^3$

# Pink Beam Stop Pressure Set Points:

- The Pink Beam Stop is charged with air or nitrogen to a nominal system pressure of 10 psig
- The low pressure set point of 8.75 psig alerts the personnel safety system (PSS) system to close the front end photon shutter and stop the beam in the event that the beam-strike plate has been breached
- The high pressure set point of 11.5 psig alerts the beamline equipment protection system (BLEPS) system to close the beamline photon shutter and stop the beam so that the Pink Beam Stop will not exceed the safe touch temperature limit

*Safe Touch Temperature Limit: 50°C*

$$P_{Charge} = 10 \text{ psig}$$

$$P_{Lo} = 8.75 \text{ psig}$$

$$P_{Hi} = 11.5 \text{ psig}$$

Pink Beam Stop System Pressure as a Function of System Gas Temperature

System Pressure (psig)	System Gas Temperature (°C)
10.0	25.6
10.2	28.2
10.4	30.7
10.6	33.3
10.8	35.9
11.0	38.5
11.2	41.1
11.4	43.7
11.6	46.3
11.8	48.9
12.0	51.5

# Experimental Program Outline:

- Overview of laser system , test chamber and Pink Beam Stop prototype
- Calibration of the weld head focal distance vs. delivered beam diameter
- Absorption of laser energy into bare copper
- Maximum penetration depth in copper for the worst-case DCS beam condition
- System pressure response with varying beam diameters and beam exposure locations
- Pink Beam Stop minimum beam detection time
- Using the Pink Beam Stop as a calorimeter



# Fiber Optic Laser System & Weld Head:

## Laser System Specifications:

- Central Emission Wavelength: 1070 nm +/- 10 nm
- Operational Modes: CW / Modulated
- Rated Output Power: 400 W -0 W / + 10 W
- Beam Diameter (1/e<sup>2</sup>): 5.0 mm +/- 0.7 mm
- Full Angle Divergence: < 0.45 mrad
- M<sup>2</sup>: < 1.10
- Emission Bandwidth: < 6.0 nm



## FiberMini Weld Head with 100 mm Focusing Optic

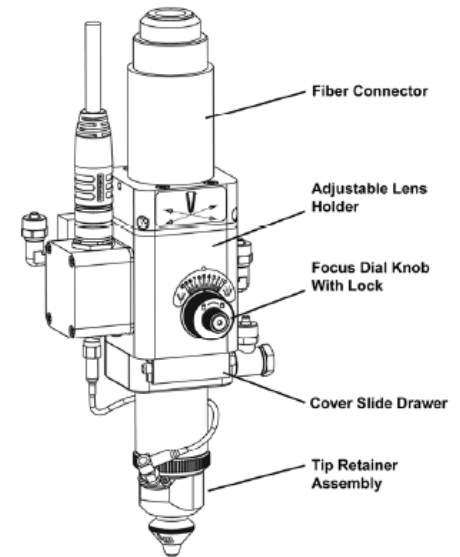

### Beam Quality M<sup>2</sup><1.1 Lasers

#### Focused Beam Quality @ 50W & 400W

Focused Spot @ 50W  
(using 512mm FL reference lens)

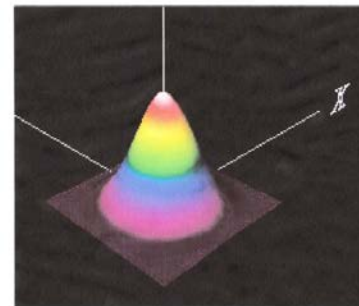

Focused Spot @ 400W  
(using 512mm FL reference lens)

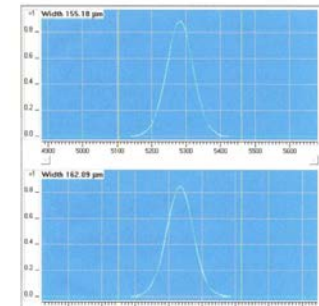



# Pink Beam Stop in the Laser System Test Chamber:

Laser weld head & 90° beam bender

Pressure tap to the Yokogawa differential pressure transmitter

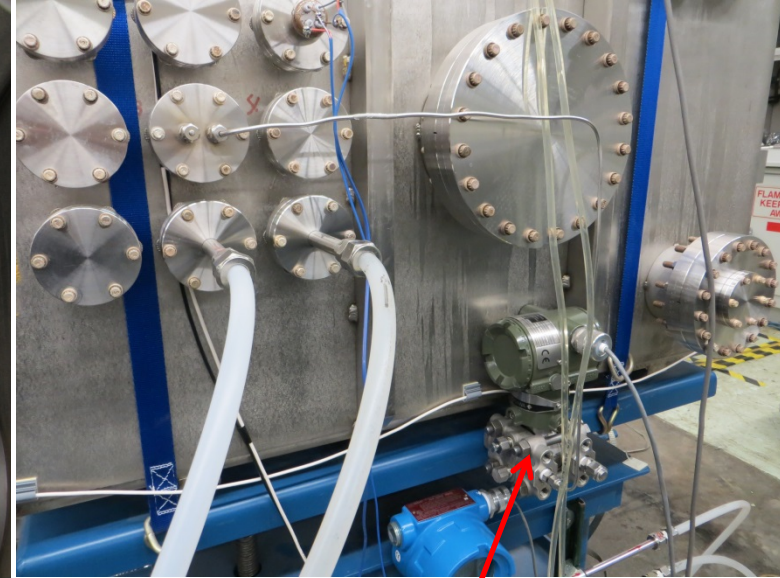
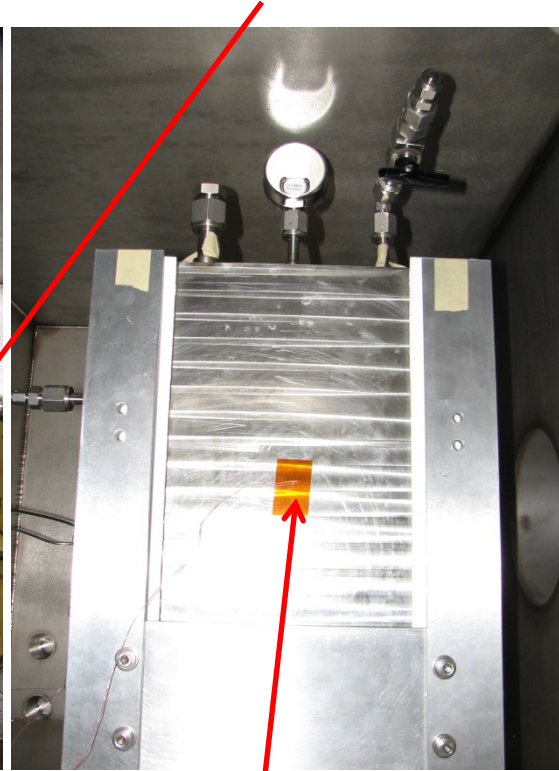
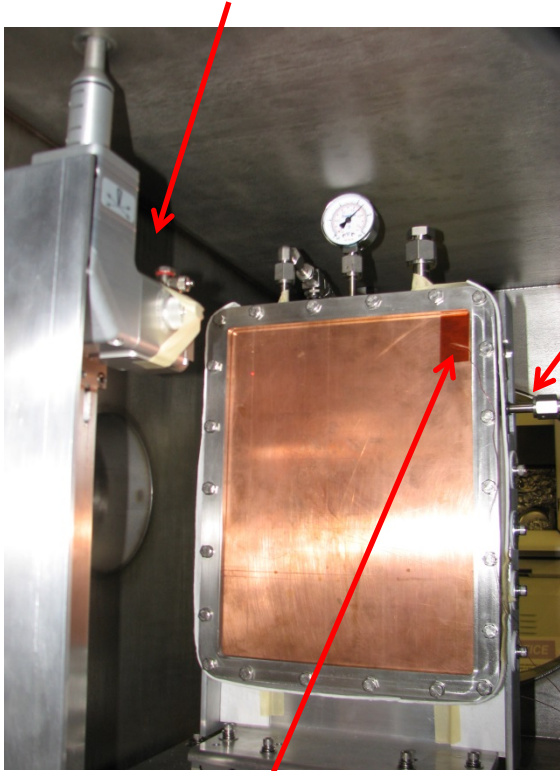

Thermocouple on right top corner of beam strike plate

Thermocouple on back center of the Pink Beam Stop assembly

Yokogawa differential pressure transmitter & capillary line into the laser system chamber

- Pink Beam Stop is thermally isolated from the holder with 1/8" thick ceramic felt and ceramic washers on all mounting bolts

# Laser System & Test Chamber:

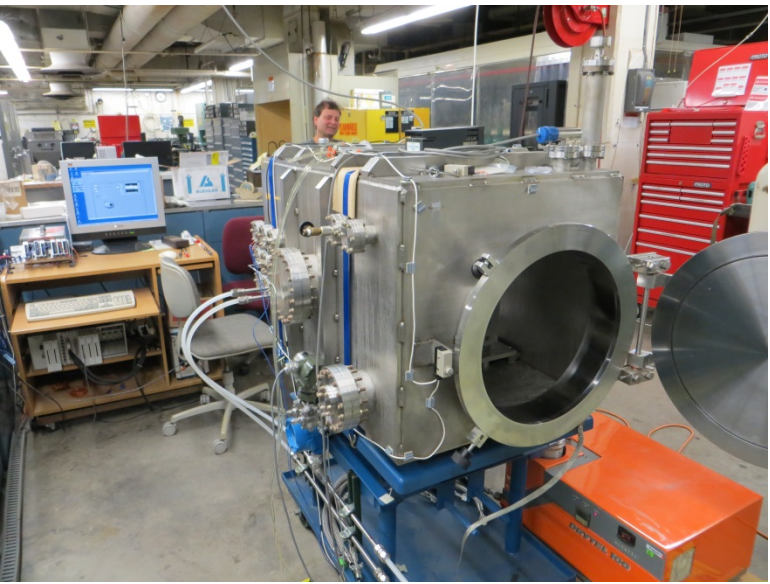
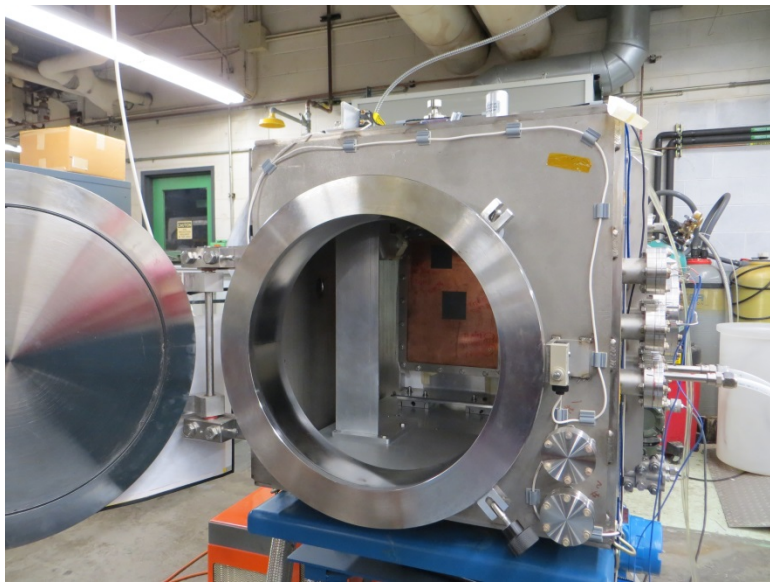
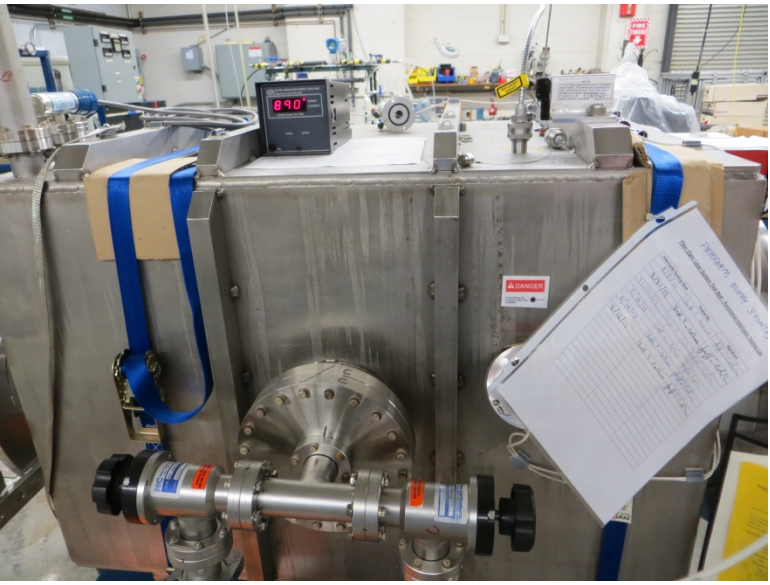
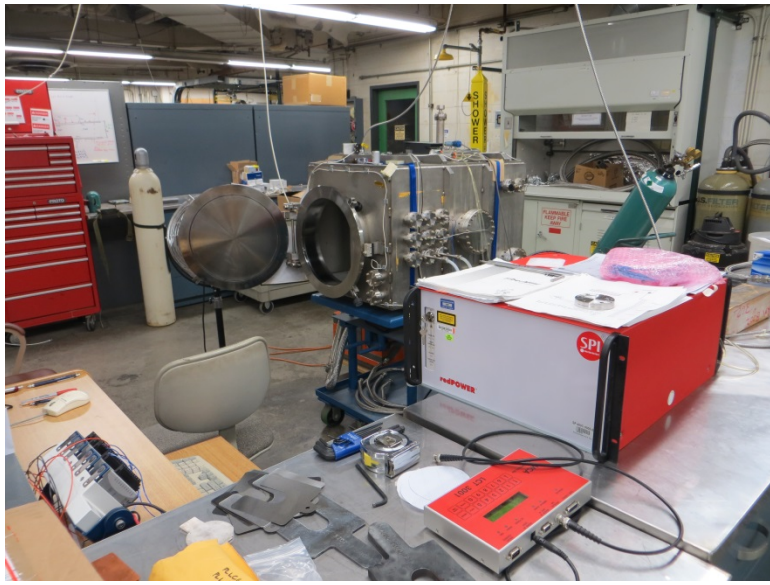

Dynamic Compression Sector (DCS) Project



# Before Pink Beam Stop Testing Can Begin...

1. Must verify the power output from the fiber optic laser system
2. Must calibrate the weld head to determine the delivered beam spot diameter vs. weld head focal distance
3. Must perform a series of calorimetry measurements to determine the laser power absorption into bare copper for the focused beam cases (64  $\mu\text{m}$  dia. beam)
4. Must perform calorimetry measurements to determine the laser power absorption on a copper surface coated with nanoparticle carbon for the raw collimated beam cases (5100  $\mu\text{m}$  dia. beam)

- Applied with an artist's air brush
- % Absorption measured to be 87.45%



# Verification of the Laser Power Output:

- Verified laser power output using a model #30 digital power probe by Optical Engineering Inc.
- Used two different heads to cover the power output range from 400W to 10W
- Meter error is +/- 3%



Laser Set Power (W)	Measured Power (W)
400	401.3
350	351.9
300	300.1
235	237.9
169.3	170.1
135	136.5
100	97.8
75	74.8
50	49.1
25	24.2
10	9.5

# Calibration of the Laser Weld Head:

*Need to match the Total Power and Peak Heat Flux for the worst-case DCS beam condition using a fiber optic laser with a focusing weld head*

1070 nm Wavelength Fiber Optic Laser and  
Laser Mech 200 mm Focusing Optic Weld Head

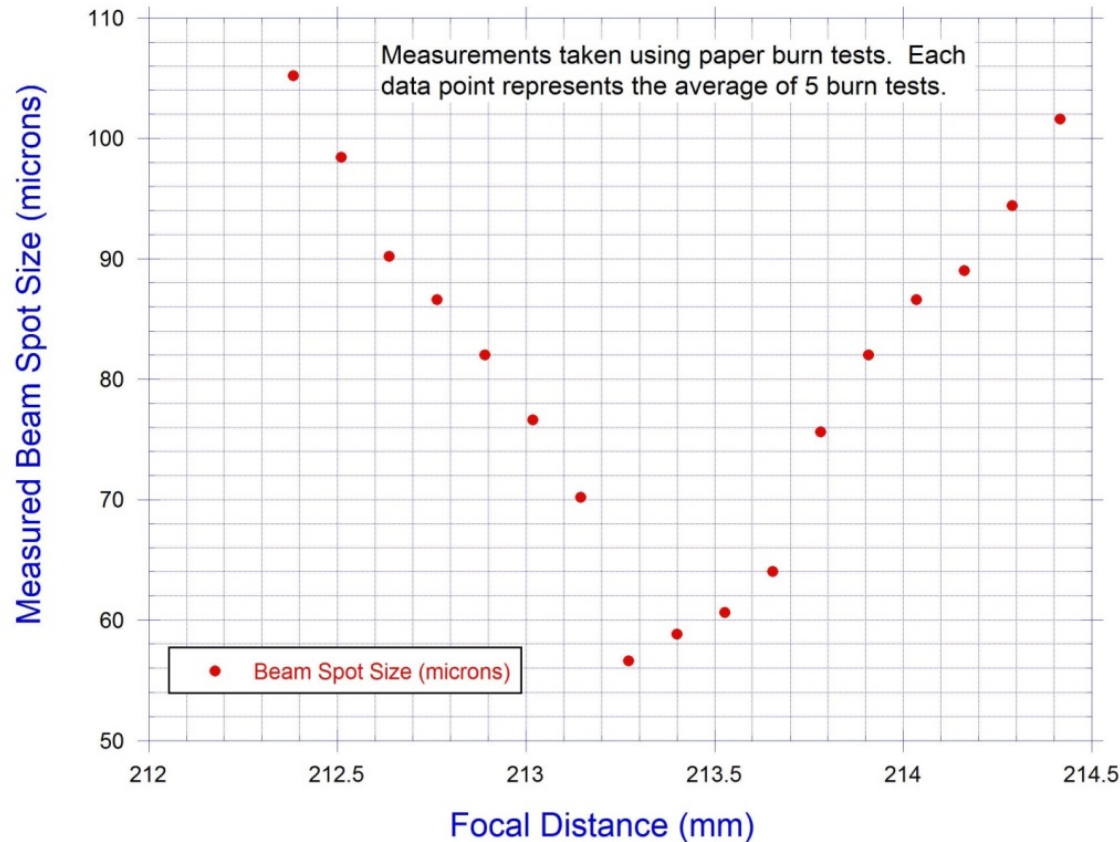

➔ Beam Diameter = 64  $\mu\text{m}$  to match the worst-case beam condition

# Laser Power Absorption into Bare Copper:

Absorption into Bare Copper using a 1070 nm Wavelength Fiber Optic Laser Source

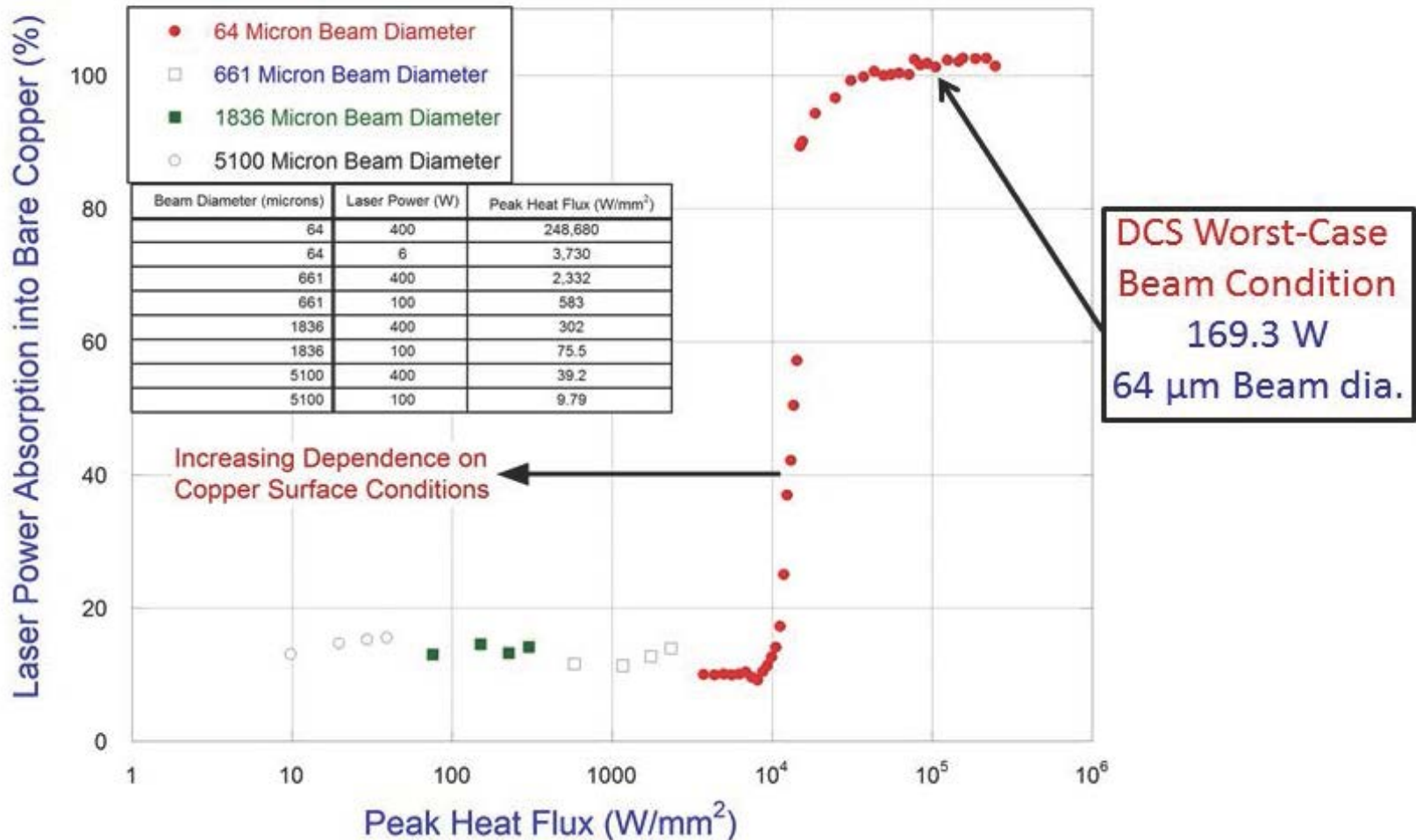

- Absorption dramatically increases between 10,000 - 20,000 W/mm<sup>2</sup> peak heat flux
- Above ~ 25,000 W/mm<sup>2</sup> peak heat flux the absorption is nearly 100%

# Pink Beam Stop Testing Conditions:

- All tests were conducted in air
- The laser beam was continuously applied onto the beam strike plate throughout each test
- The laser beam remained on until the system pressure reached just over 12.0 psig, requiring ~ 39 minutes of continuous exposure under worst-case DCS beam condition
- The system pressure and thermocouple data were recorded using a customized LabVIEW program
- The surface damage caused on the beam strike plate was imaged using a 3-D optical microscope system
- Samples were metallurgically sectioned in 15  $\mu\text{m}$  increments across the damaged area to reveal the microstructure

# Metallurgical Images for Worst-Case DCS Beam Condition:

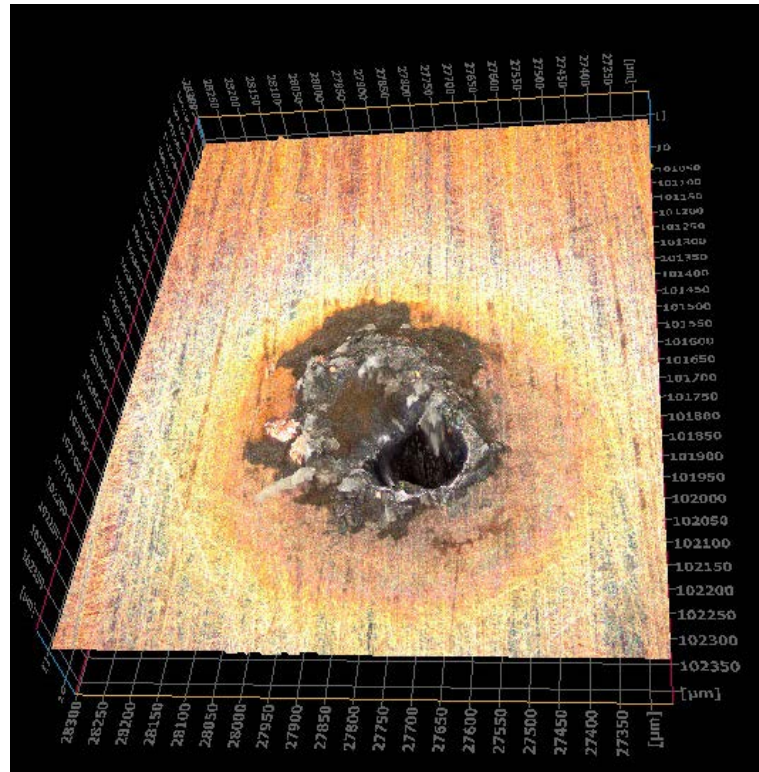
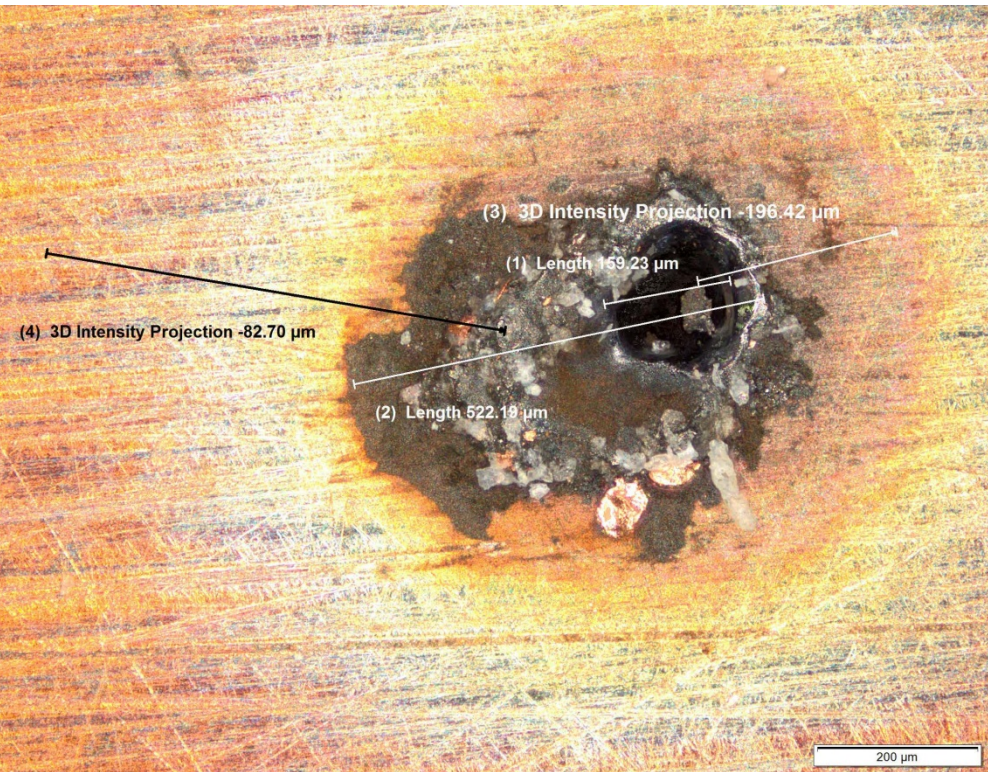

Copper Boiling Point = 2562°C

Copper Melting Point = 1085°C

[Digital Camera Movie](#)

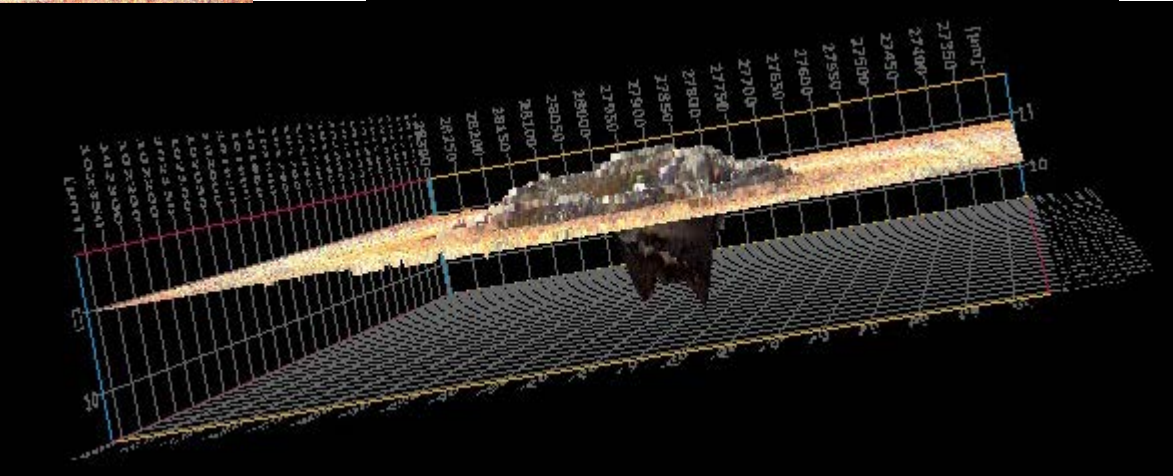

Dynamic Compression Sector (DCS) Project





# Maximum Penetration Depth:

## Wall Thickness Dependence on Maximum Penetration Depth

For the Worst-Case DCS Off-Normal Beam Condition

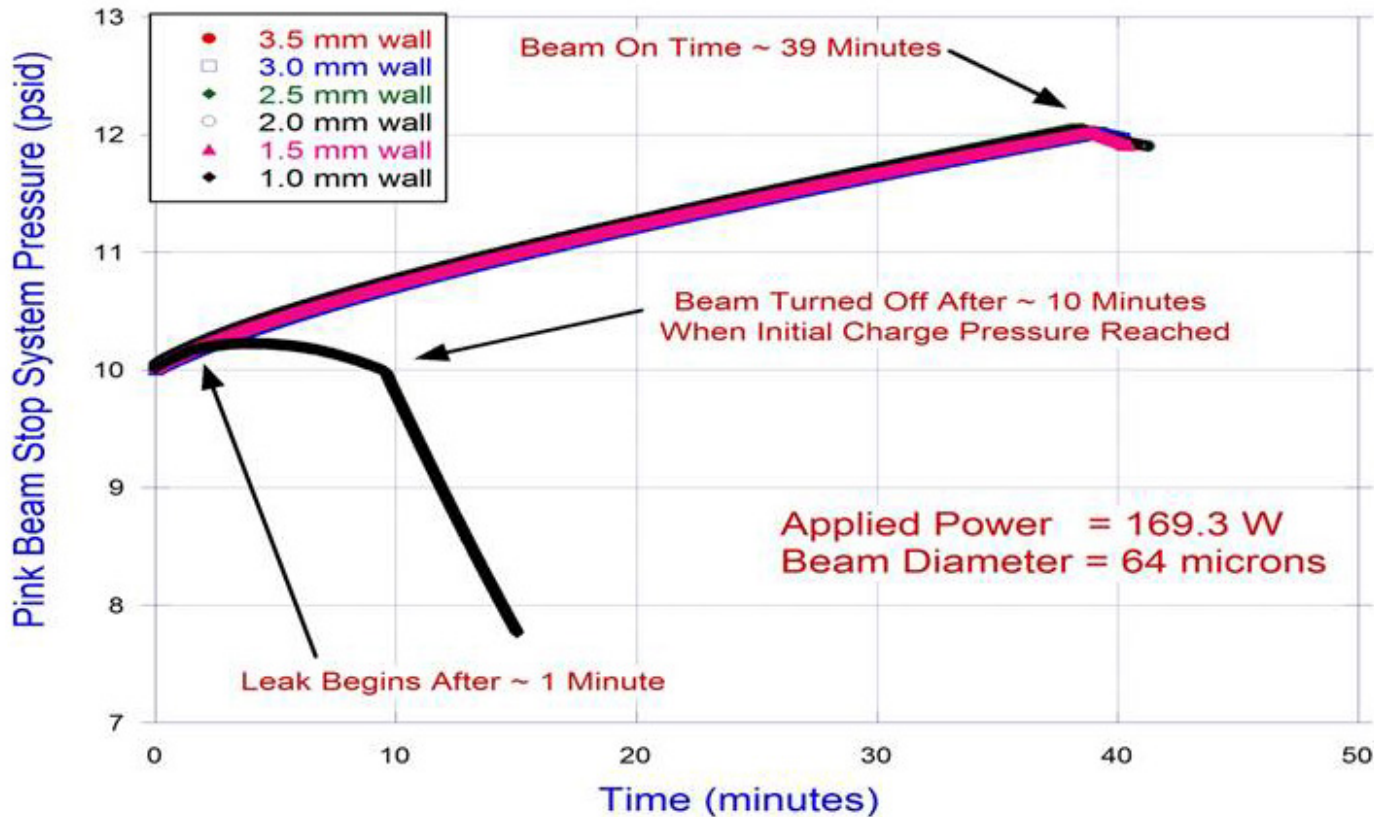

Metallurgical section of laser<sup>100 μm</sup>  
drilled hole in copper

- A leak developed after ~ 1 minutes with the 1.0 mm wall thickness case
- The maximum penetration depth with the worst-case DCS condition was measured to be 1.1 mm (→ Factor Of Safety > 5 with a 6.35 mm beam strike plate)

# System Pressure Response with Varying Beam Diameter Sizes and Beam Exposure Locations:

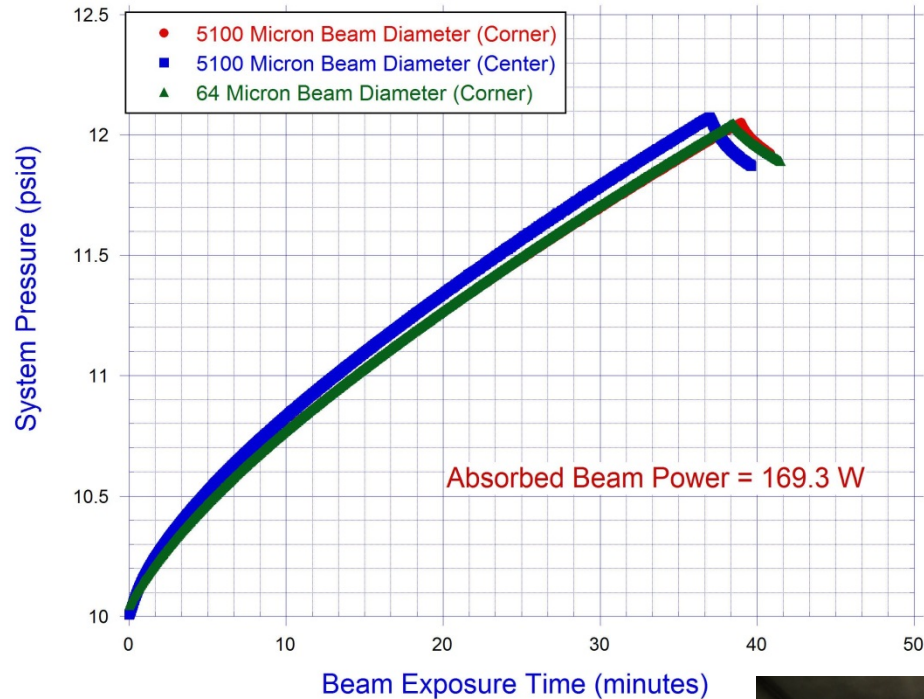

Nanoparticle carbon paint applied with an air brush

64 Micron Beam Diameter

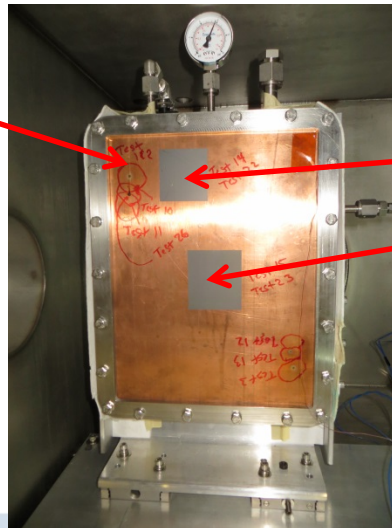

5100 Micron Beam Diameter

5100 Micron Beam Diameter

- Pressure response insensitive to beam diameter
- Pressure response nearly independent of beam location

Nanoparticle Carbon Absorption = 87.45%  
Applied 193.59 W to Absorb 169.3 W

# Pink Beam Stop Minimum Beam Detection Time:

The Time Required to Begin Increasing the System Pressure after the Beam is Turned On

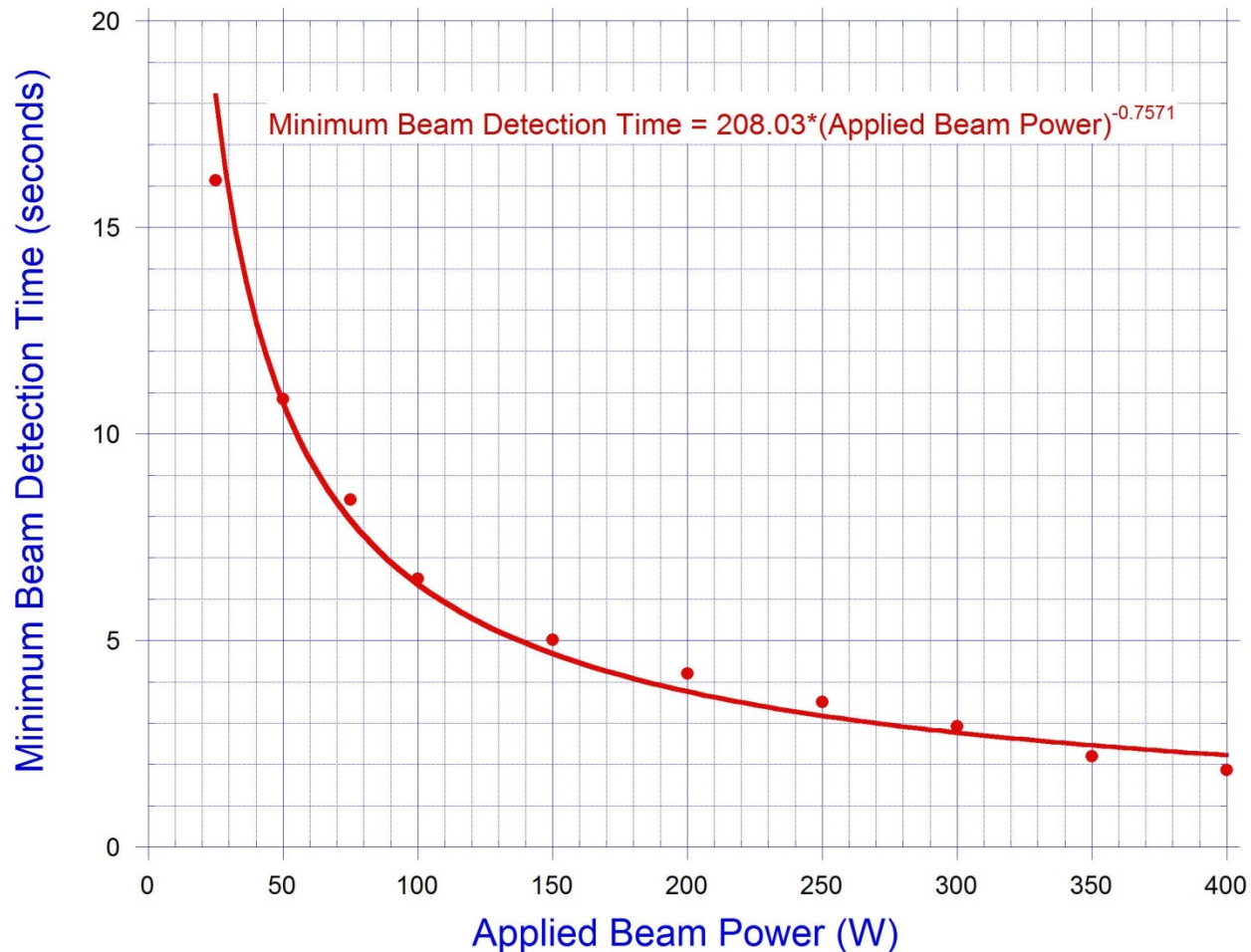

- The minimum beam detection time decreases with increasing applied power
- For the worst-case DCS beam condition the beam can be detected in ~ 4 sec.

# System Pressure Response for Short Beam Exposure Times:

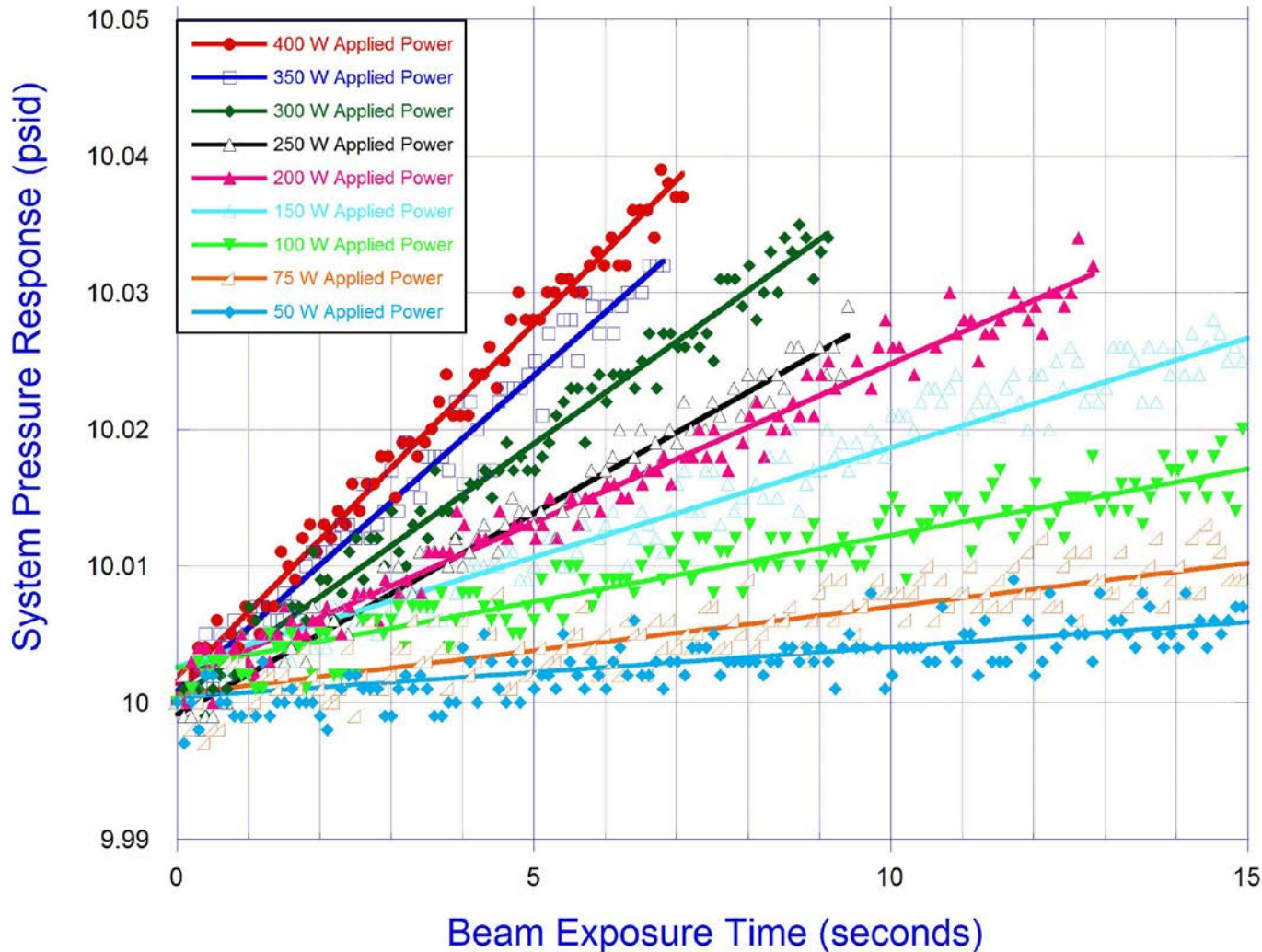

- System pressure response is rapid and very linear regardless of applied beam power
- In each case here, only a few seconds are required to capture a linear pressure slope

# System Pressure Rise Slope at Various Beam Power Levels:

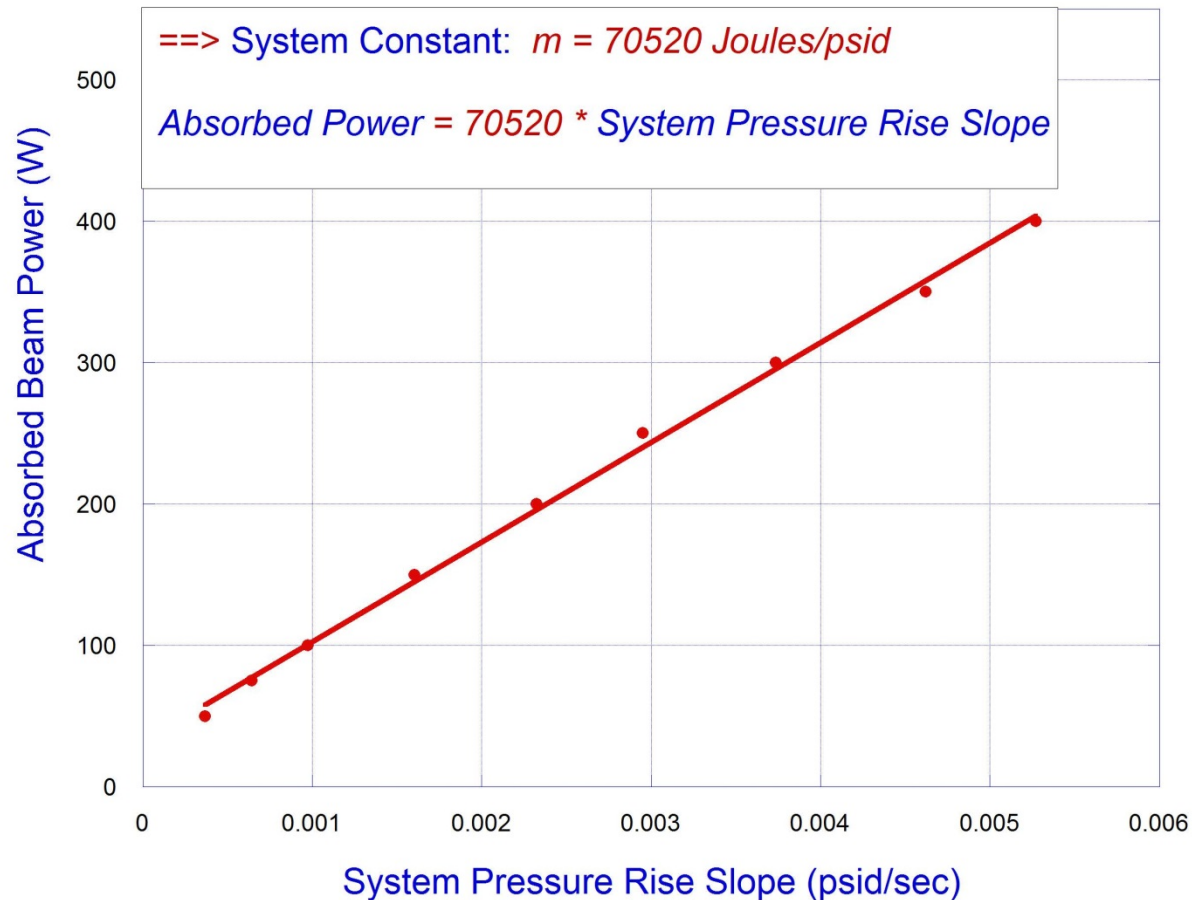

- The system pressure rise slopes from the previous plot are plotted against absorbed beam power and the results are very linear
- The [Pink Beam Stop Can Be Used as an Accurate Calorimeter](#) to measure beam power
- The calorimeter measures *Retained Power*, not Absorbed Power
- However, Absorbed Power  $\approx$  Retained Power in the first few minutes of beam exposure because free convection has not had sufficient time to influence the pressure rise slope

# DCS Pink Beam Stop Installation:

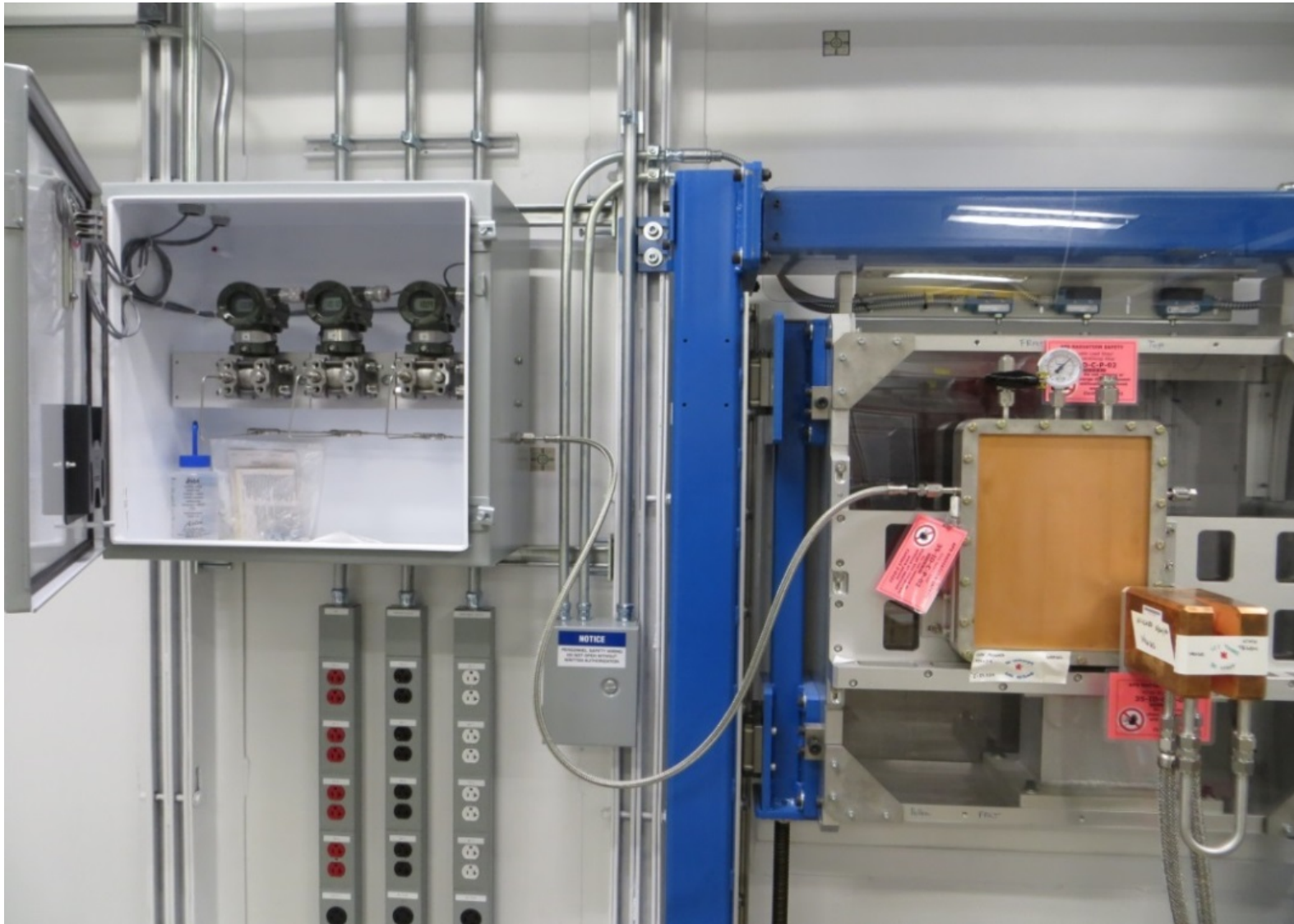

Four Pink Beam Stop assemblies have been installed in the DCS beamline

## Conclusions:

- The Pink Beam Stop will stop the beam under the worst-case DCS beam condition
- A breach in the beam strike plate can be positively identified by a drop in system pressure and this will trigger PSS to close the front end photon shutter
- Reaching the high pressure set point will trigger BLEPS to close the beamline photon shutter before the body temperature of the device exceeds a safe touch temperature of 50°C
- The Pink Beam Stop can detect the presence of the beam
- The Pink Beam Stop can be used as an accurate beam calorimeter

# Why Using A Copper Plate & Thermocouple As A Beam Stop Will Not Satisfy PSS Requirements:

## Findings:

1. We have demonstrated under worst-case DCS off-normal beam conditions that the maximum penetration depth caused by the beam strike will not exceed a depth of 1.1 mm
2. We have demonstrated that successive beam strikes on the exact same location will not drill the hole any deeper

## Conclusions:

1. Although it is highly unlikely, successive beam strikes in the vicinity of an existing hole can create a larger hole, and therefore it is possible to widen the hole and eventually drill through and breach the beam strike plate
2. The Pink Beam Stop will positively identify a breach in the beam strike plate and close the beamline photon shutter
3. A copper plate with a thermocouple used as a beam stop is unable to positively identify a breach in the beam strike plate

**→ *Using A Copper Plate & Thermocouple As A Beam Stop  
Will Not Satisfy PSS Requirements***