

Magnetic design calculations for an undulator end, a phase shifter, and both combined

Liz Moog
ASD Seminar
29 April 2015

Introduction

- An undulator should be transparent to the electron beam – no net kick and no significant offset after passing through.
- Integrals (first and second) affect the stored electron beam. The first integral is the net deflection of the electron beam; the second integral is the offset.
- In addition, users want their photon beam at a constant angle.
- The angle of the photon beam is determined by the average trajectory angle in the undulator, which is in turn determined by what happens at the entrance end of the undulator.
- The ends of the undulator are significant contributors to a well-behaved undulator.



Additional requirements for FEL undulator

- In a free-electron laser like LCLS, straightness of the trajectory is vital. The electron and photon beams have to overlap for the interaction between them to cause longitudinal bunching of the electron beam. This micro-bunching is how a brilliant and coherent photon beam is produced.
- Phase between the electric field of the x-ray beam and the wiggles of the electron beam creates the micro-bunching, so phase needs to be maintained from one undulator segment to the next.
- In LCLS-1, phase was set by magnetic tuning and installation and didn't change because the undulator gap didn't change.
- For LCLS-2, the gap will change. So active phase adjustment is needed, i.e., a phase shifter.
- Interaction between phase shifter and undulator fields prompts magnetic modeling.
- Need a magnetically realistic end for the undulator.
- Goal is to keep existing LCLS I structure to the extent possible (to save \$) while replacing undulators with the HGVPUs & adding phase shifters

Undulator end: if nothing is done (idealized case)

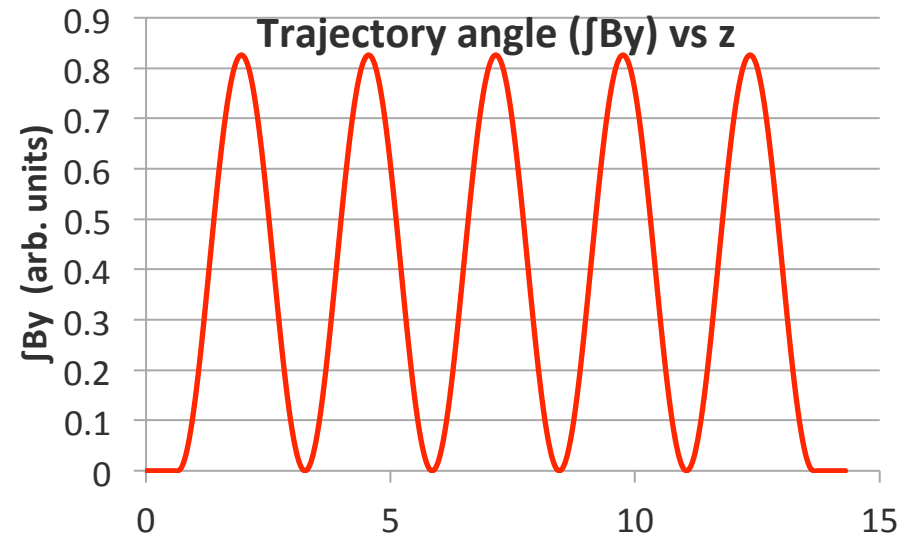
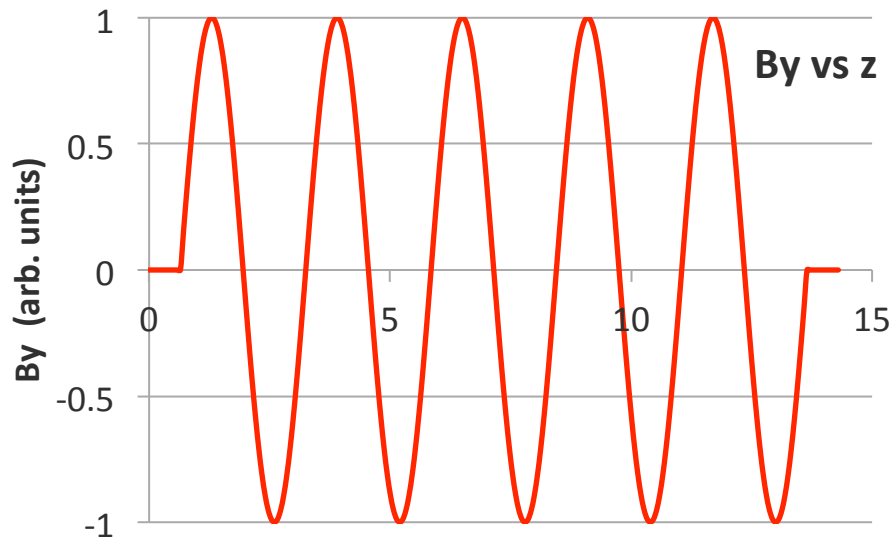

- An abrupt entry (which cannot be built) gives a trajectory angle that is always of the same sign.
- So the trajectory walks off.
- Something is needed to correct the entrance angle. Also something for the exit angle.

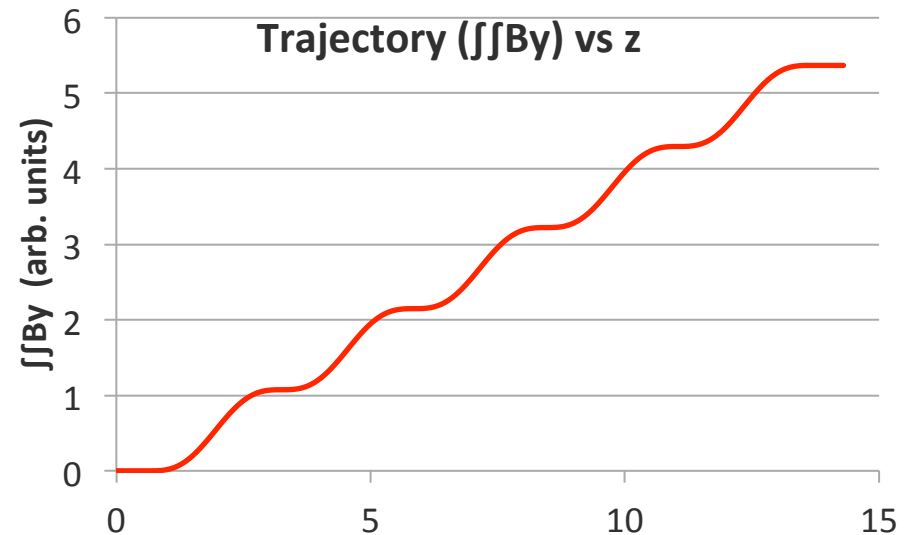

Make the end pole half as strong (idealized case)

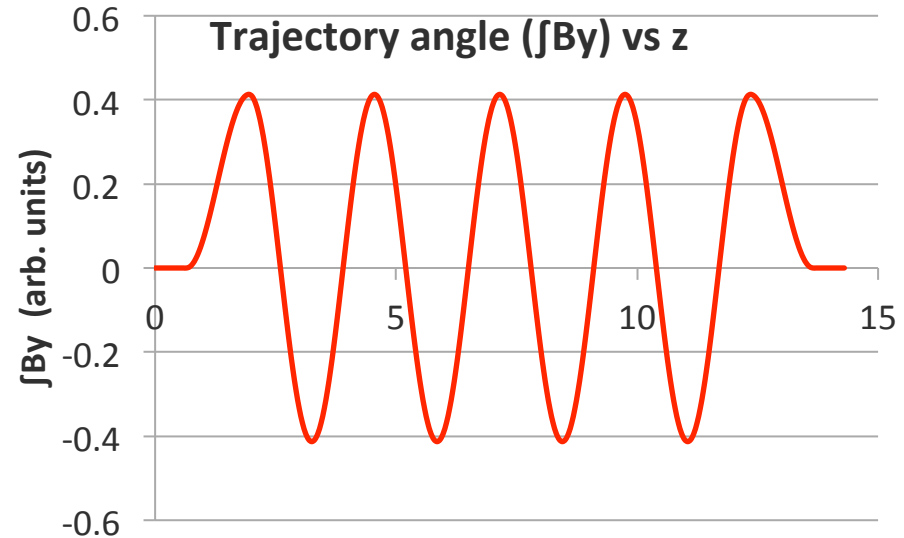
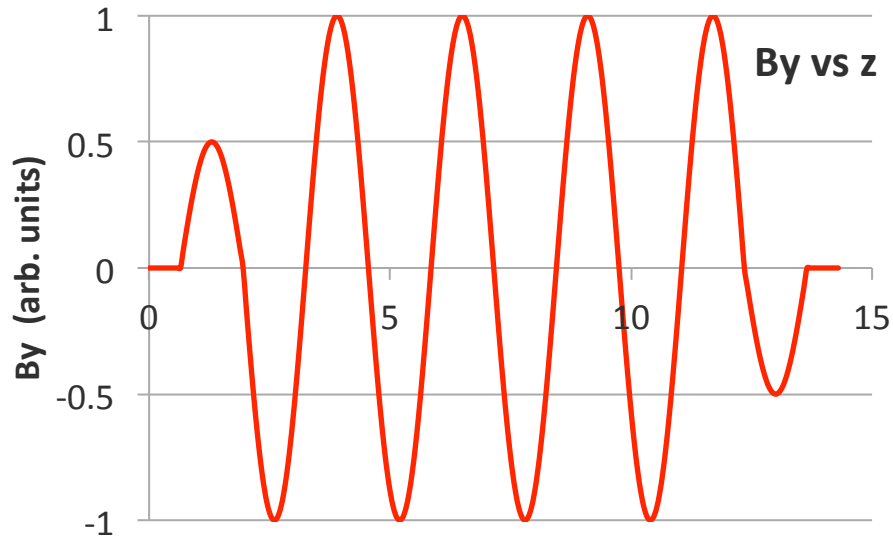

- Now the trajectory angle oscillates about zero.
- And the trajectory is parallel to the undulator axis.
- But there is an offset. Can it be eliminated?

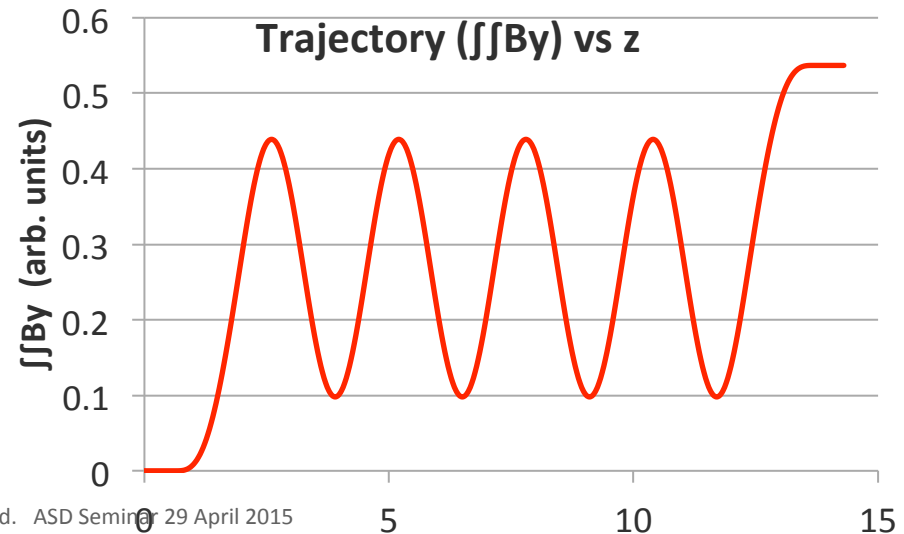

Make the end poles 25% & 75% as strong (idealized case)

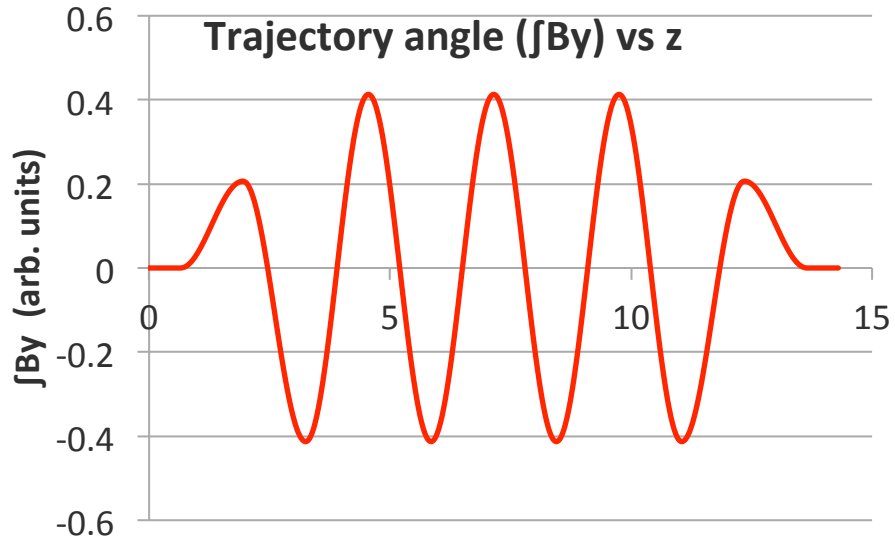
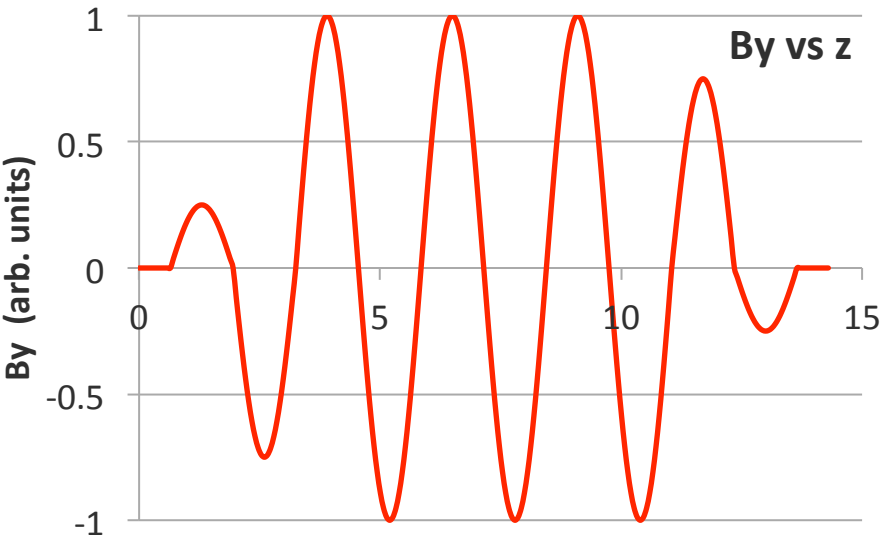

Now both the trajectory angle and the trajectory oscillate about zero, the trajectory is parallel to the undulator axis, and there is no offset.

But – how to achieve it in real life?

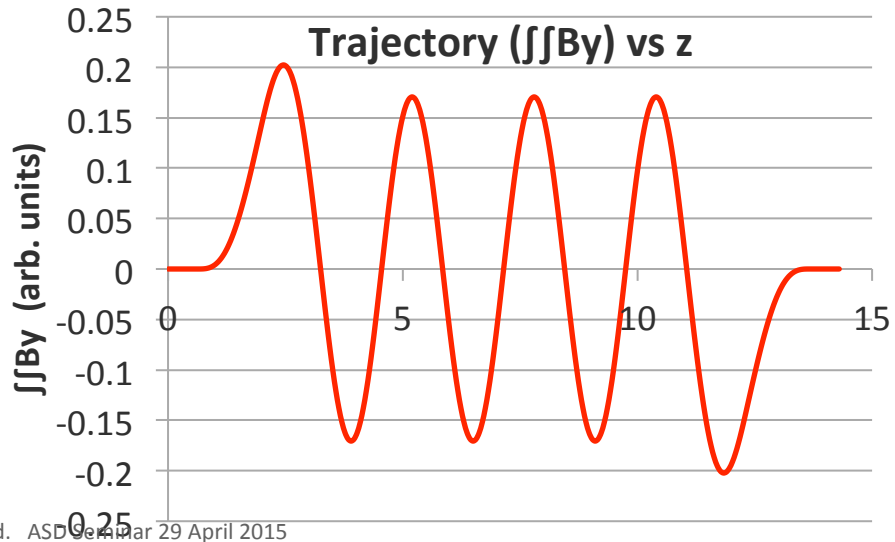

An end magnet with 50% strength?

- One could approximate that if the last magnet is half strength, the magnetic flux going into the end pole is 25% that of a full-strength pole. (There's no magnet on the other side)
- And the flux going into the 2nd pole is 75% of a full-strength pole.
- This is very approximate.
 - It ignores 3-D effects.
 - It ignores the magnetic response in the poles (and poles in an undulator are usually saturated, at least in some regions).
 - It ignores the field that extends beyond the end of the undulator
 - Flux from a magnet is not strictly limited to affecting only the adjacent pole.
- Try it in a 30-pole undulator model.



An end magnet with 50% strength?

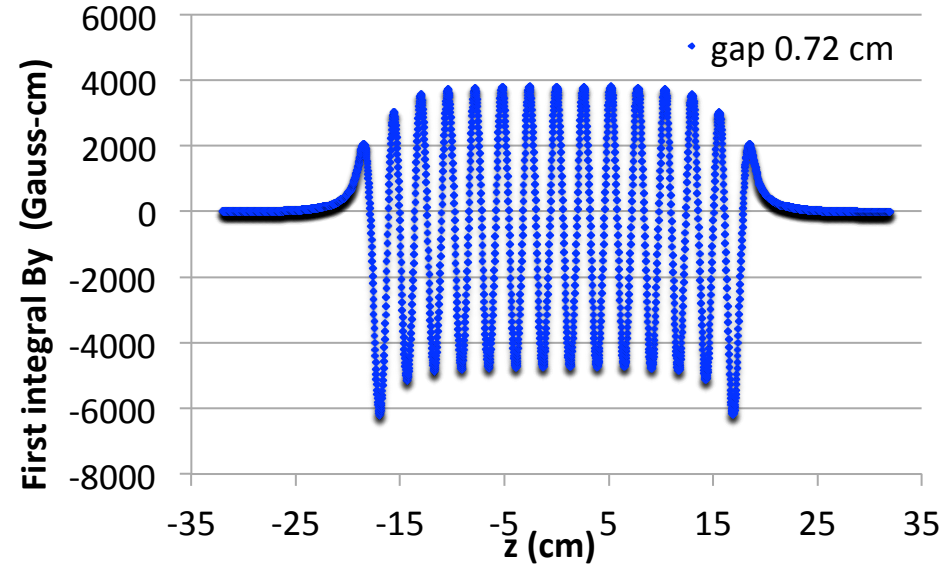
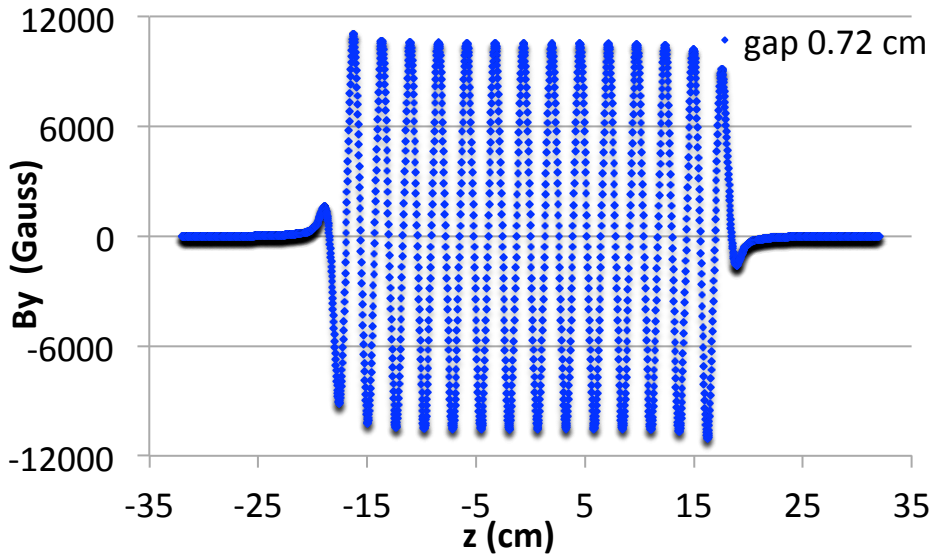

The 1st integral (angular kick) is zero after the undulator – by symmetry due to the even # of poles. Calc gives -8.5 G-cm (with attention paid to maintaining symmetry in the model). LCLS reqt: ± 40 G-cm. APS goal: < 50 G-cm

2nd integral (trajectory). LCLS reqt ± 5000 G-cm²; APS goal < 50000 G-cm²

Note that 30 poles is ~ 0.75 m long.

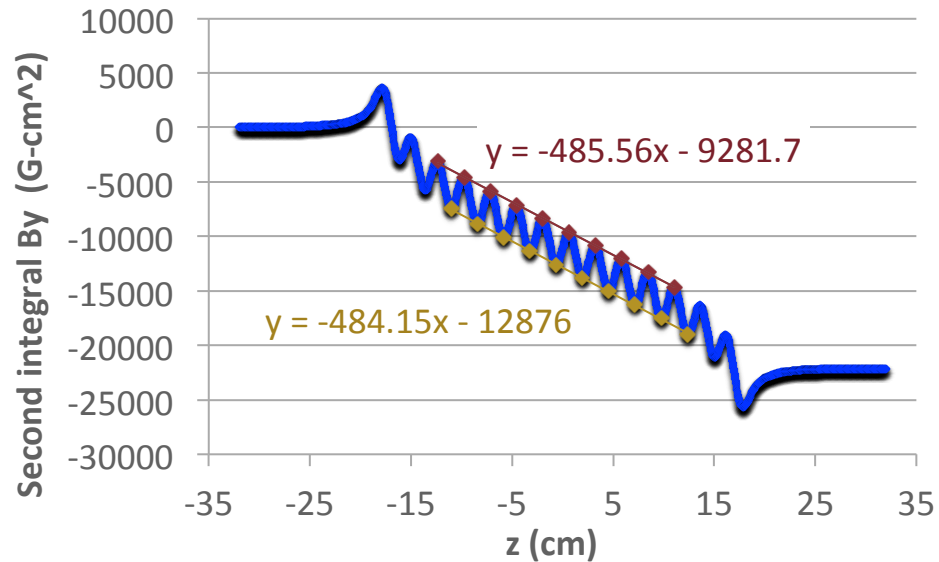

Need to adjust two magnets

- So, the simple approximation doesn't even come close
- Nikita Strelnikov tried adjusting the strength of just the end magnet, without achieving good results.
- Next step: adjust the strength of the two last magnets.

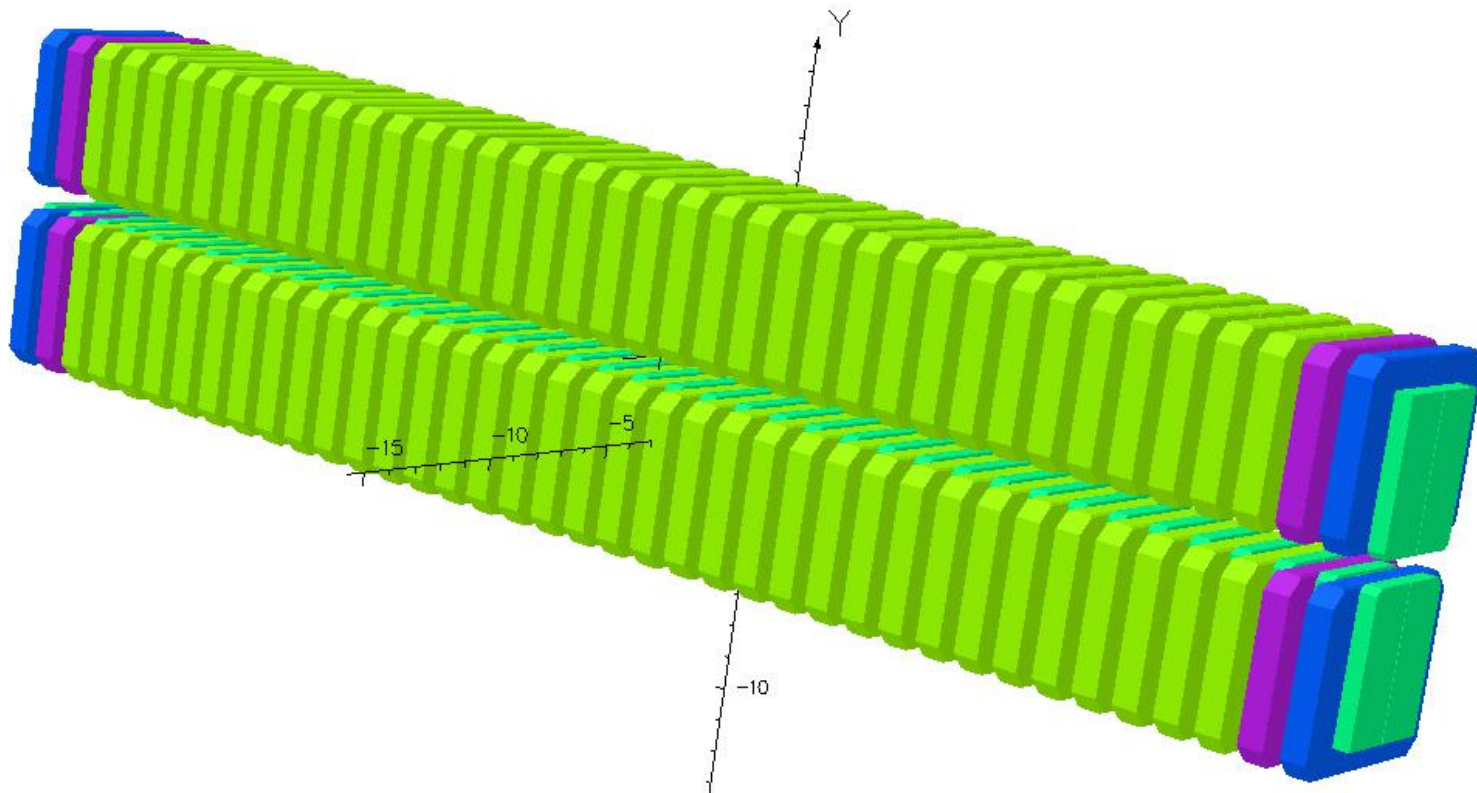

Choosing end magnet strengths

- A fully-parameterized .comi file was written for Vector Fields' Opera 3D. It allows the (even) number of poles to be changed, the strength of the two last magnets to be changed, etc.
- First integral through the entire undulator should be identically zero by symmetry since it is an even number of poles, but that doesn't mean the averaged trajectory angle inside the undulator is zero or that it doesn't change with gap. There can be a non-zero first integral through just the entrance end.
- This angular kick through the end results in the photon beam being emitted at an angle, and the angle may change with gap. However, in an FEL, the electron and photon beams need to overlap.
- Goal for a good end configuration is to minimize variation in trajectory angle with gap, and to minimize the angle too.
- Start with a 12-pole undulator for initial investigations...

Calculate trajectory inside undulator

- Seek a means of defining the trajectory angle:
- Linear fits to all points inside undulator were very sensitive to choice of ends
- Realized I was judging the quality of a means of determining the average trajectory angle by looking at the trajectory peaks.
- Ignore 3 poles at each end that are obviously bad. That leaves 6 central poles.

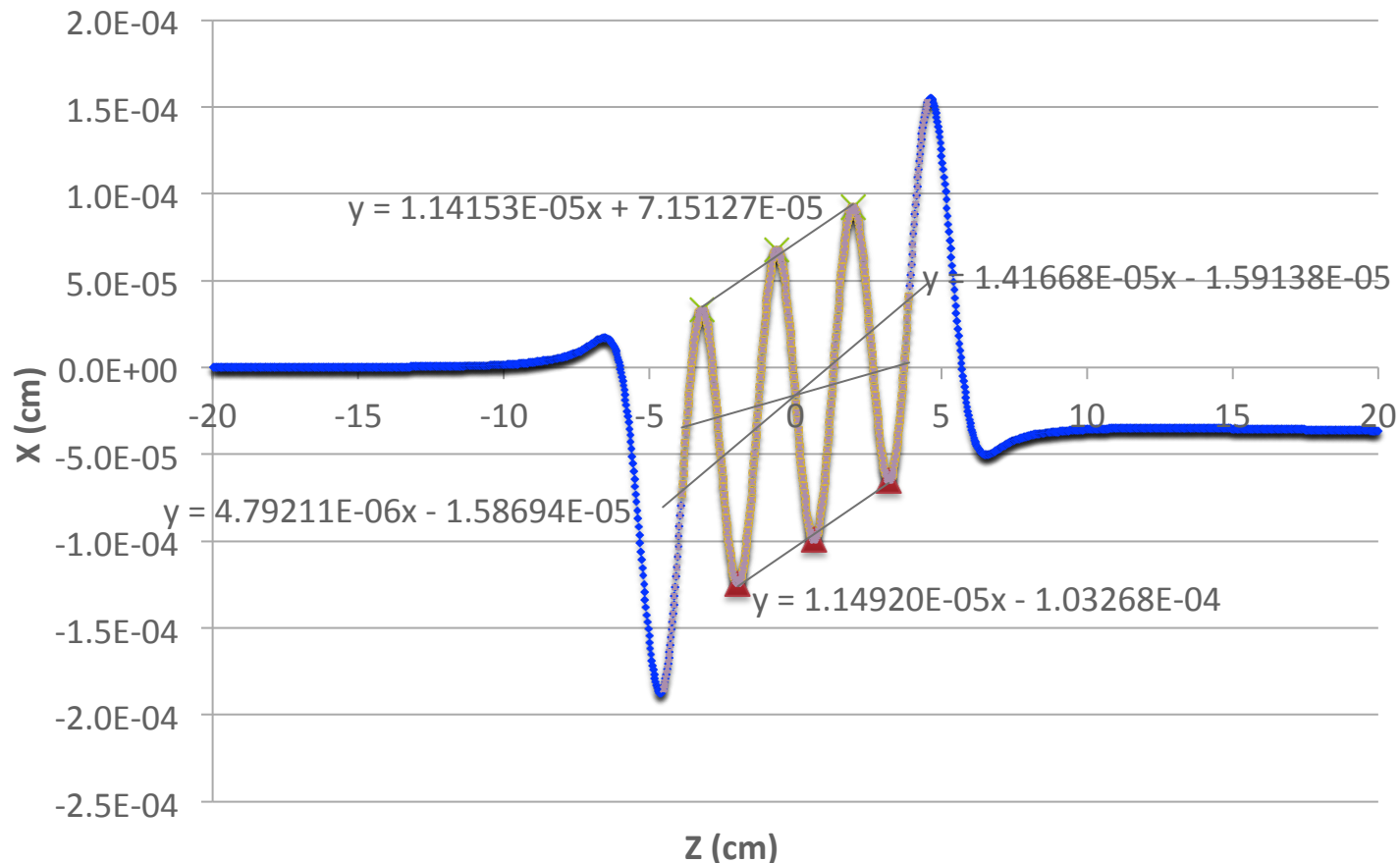

- With 12 poles, this undulator is short. Too short.
- It is being used to develop & test a process – to figure out how to address the problem generally and to automate it. Results on a longer undulator will be shown later.
- For this short undulator, average trajectories were determined as a function of gap for a variety of end configurations. End magnet strengths of 15%, 18%, 21%, and 24% were calculated, along with next-to-end magnet strengths of 65%, 69%, 73%, 77%, and 81%.
- Our magnetizer can be used to set the strength of a magnet to within about 1%, so the size of the steps between strengths can (and will) be decreased.

A few details for Vector Fields (VF) users

- Opera has a trajectory calculation built in. I began by using it, but found that the z positions where it reported the x position were not necessarily the same as, for instance, the center of the pole where the field is a maximum. When determining the trajectory angle, one really wants the positions of peak field where the photon emission is strongest.
So, instead I had Opera give B_y at z points on my grid and did the field integrals using the simple sum of $(B(z)+B(z-\Delta z)) * \Delta z / 2$.
The Δz used is 0.025 cm, so there are 104 steps per period and data points at the center of each pole and magnet.
- To allow the number of poles to be a variable parameter, a module including the pole and magnet was built and then replicated to make the necessary poles. The nested air blocks surrounding the pole and magnet were all $\frac{1}{2}$ period long. This made for an inherent $\pm z$ asymmetry in the model. It also gave a first integral of ~ 70 G-cm instead of zero. (For comparison: at APS, a goal is 50 G-cm; at LCLS, the reqt is ± 40 G-cm). Rearranging the air blocks to make separate air slices around the magnet and pole reduced the first integral to < 4.9 G-cm.

A few details for VF users, cont.

- It was convenient to use the optimizer to do the calculations on my chosen grid, because of the handy results file the optimizer prepares with all the results together in the same data file.
However, the optimizer runs .comi files differently than when you run the comi file as a lone job and the conversion is not robust yet. A .comi file that ran fine by itself didn't work when run by the optimizer. After much head-scratching, a code walkthrough with Mark J, etc., and, finally, consultation with VF, work-arounds were found.
 - Separate sections of .comi code were used to assign the magnetization directions of all the magnets and to assign different MATERIALLABELS to the end magnets. If the VOLUMELABEL designating the field direction was set second, it also changed the MATERIALLABELS in unwanted ways. The workaround was to swap those sections of code.
 - Initially, separate BH files were created for the different magnet strengths and code was written to select the appropriate file for the given run. It worked. In the optimizer, however, the same BH file was always read. The work-around was to use the MATERIALS command to set a linear mu and skip the BH file. (The BH curve for the magnet is usually a straight line anyway, so this doesn't change the results).

Results for constant next-to-end magnet strength

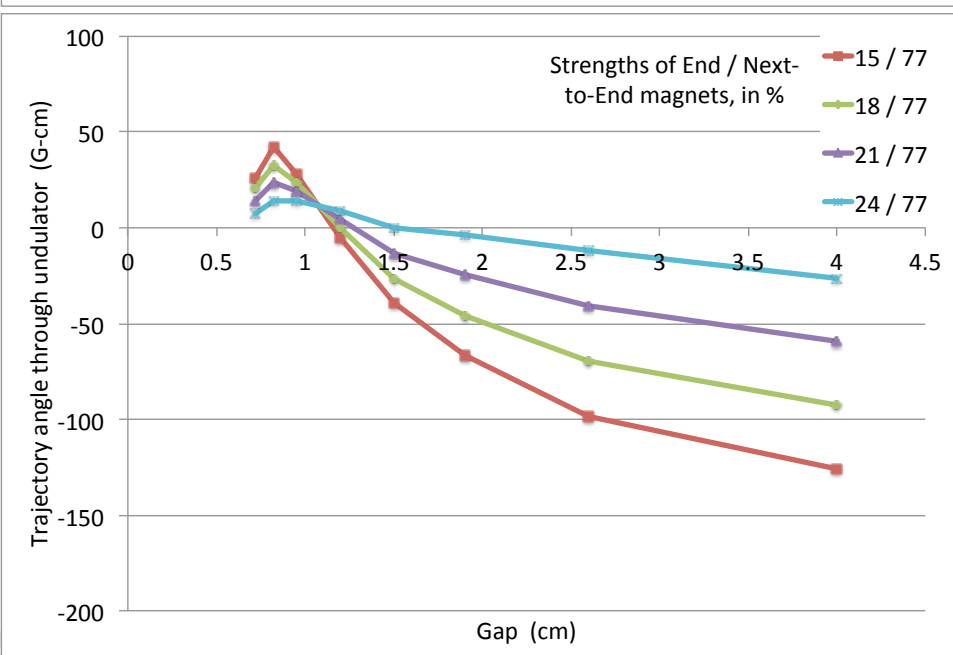
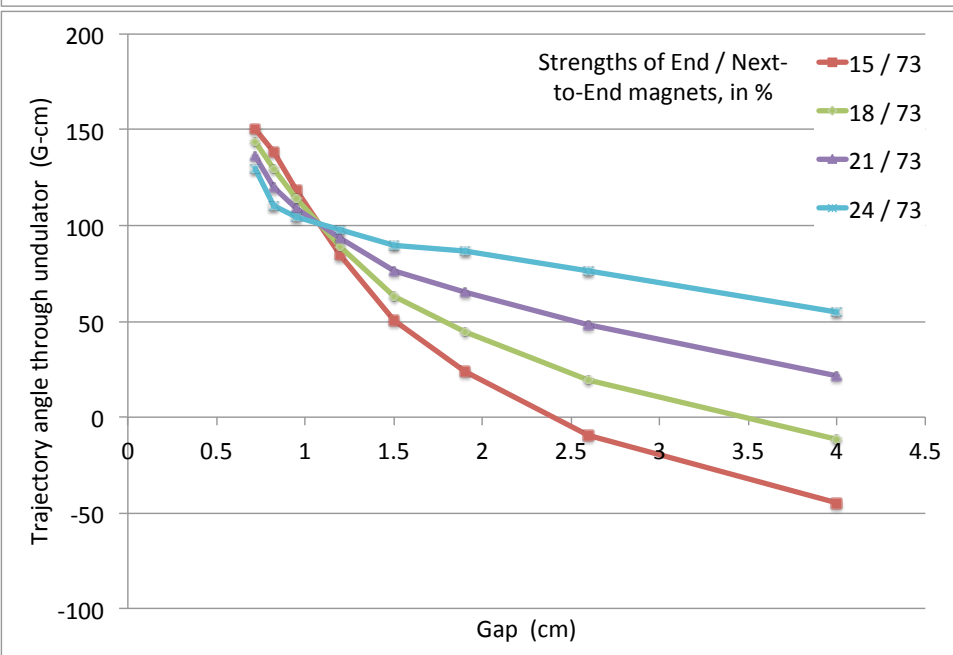
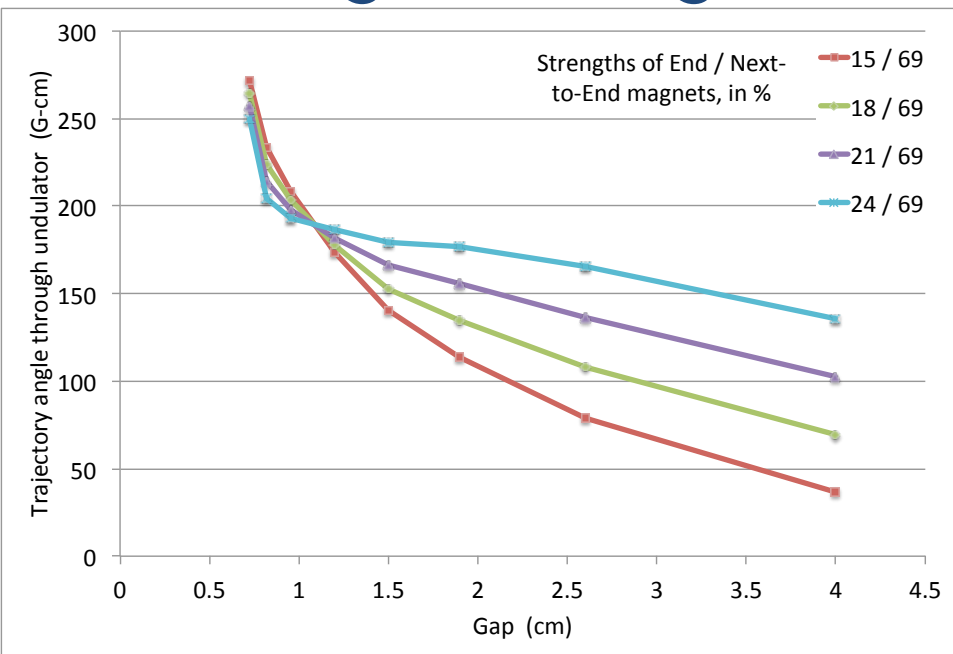
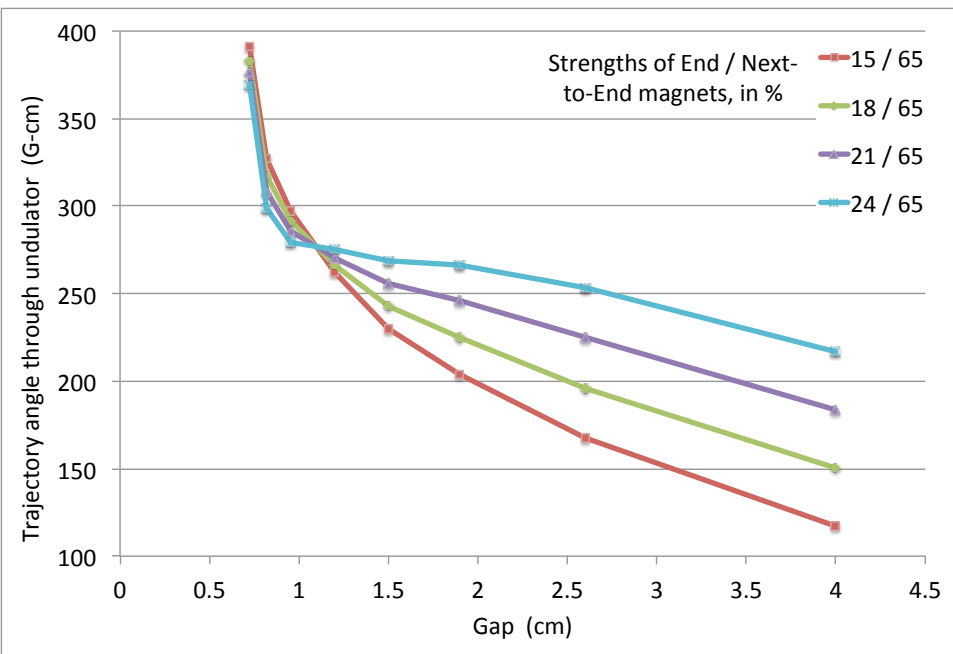

Results for constant next-to-end magnet strength, cont.

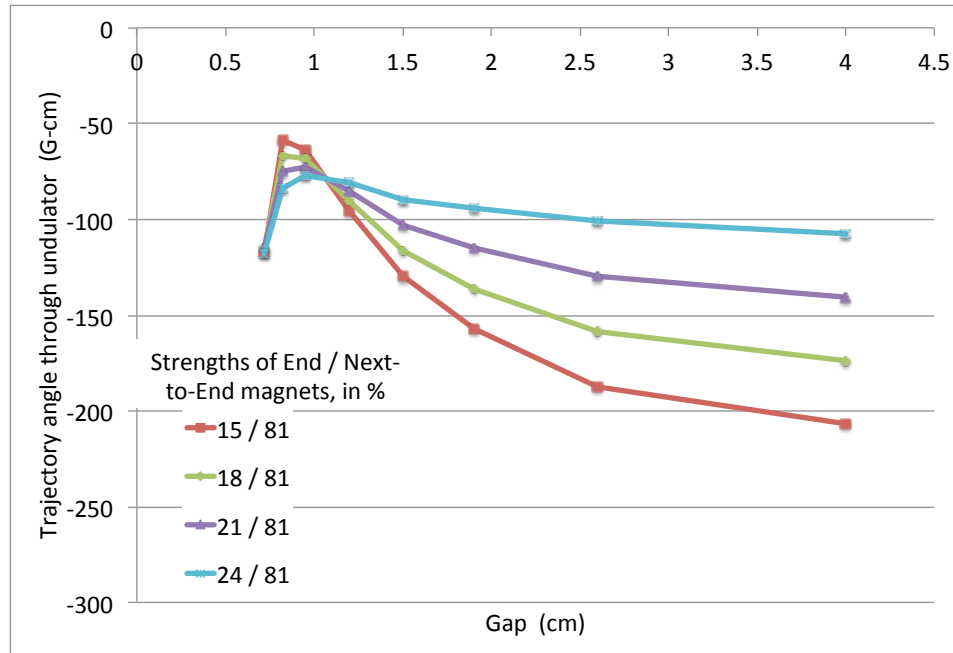

- As move from graph to graph, next-to-end magnet strength changes.
- Range of angles always spans 300 G-cm, but the zero changes between graphs.
- Notable effects:
 - Slope at smaller gaps changes dramatically
 - Offset from zero trajectory angle moves
- Smallest slope at small gaps is for 77% strength next-to-end magnets. Trajectory angles are also closest to zero.
- Smallest variation, from +14 to -26 G-cm, is for a 24%-strength end magnet.

Model of 40-pole undulator

- Magnetic model calculations (using Opera-3D from Vector Fields) were made for a 40-pole-long, 26-mm-period undulator

29/Aug/2014 15:24:15

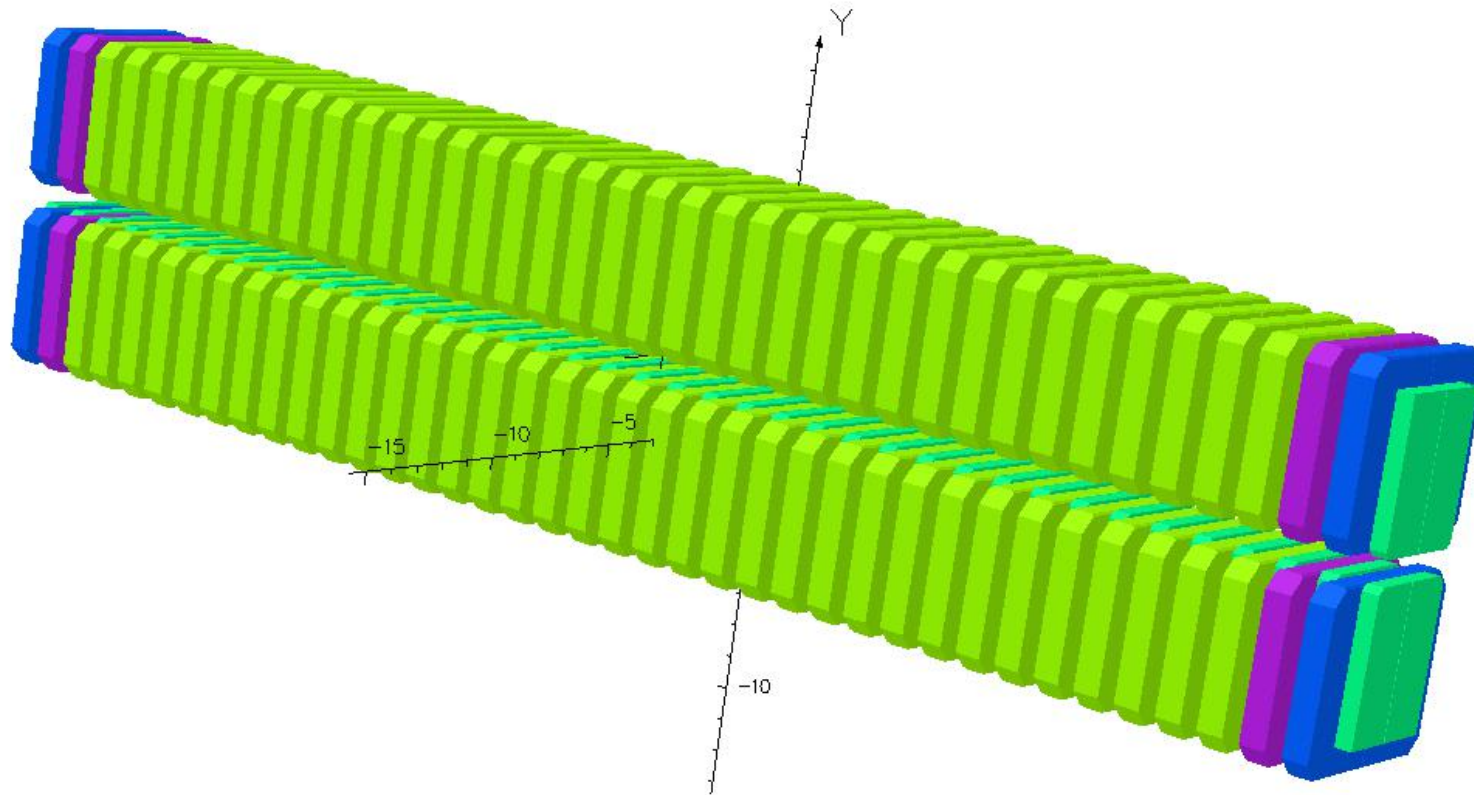

UNITS	
Length	cm
Magn Flux Density	gauss
Magnetic Field	oersted
Magn Scalar Pot	oersted cm
Current Density	A/cm ²
Power	W
Force	N

MODEL DATA
LongUnd40.op3
Magnetostatic (TOSCA)
Nonlinear materials
Simulation No 1 of 1
3832919 elements
3349937 nodes
Nodally interpolated fields
Activated in global coordinates
Reflection in YZ plane (X field=0)
Reflection in ZX plane (Z+X fields=0)

Field Point Local Coordinates
Local = Global

opera
simulation software

By vs z was calculated for a variety of gaps (40 poles)

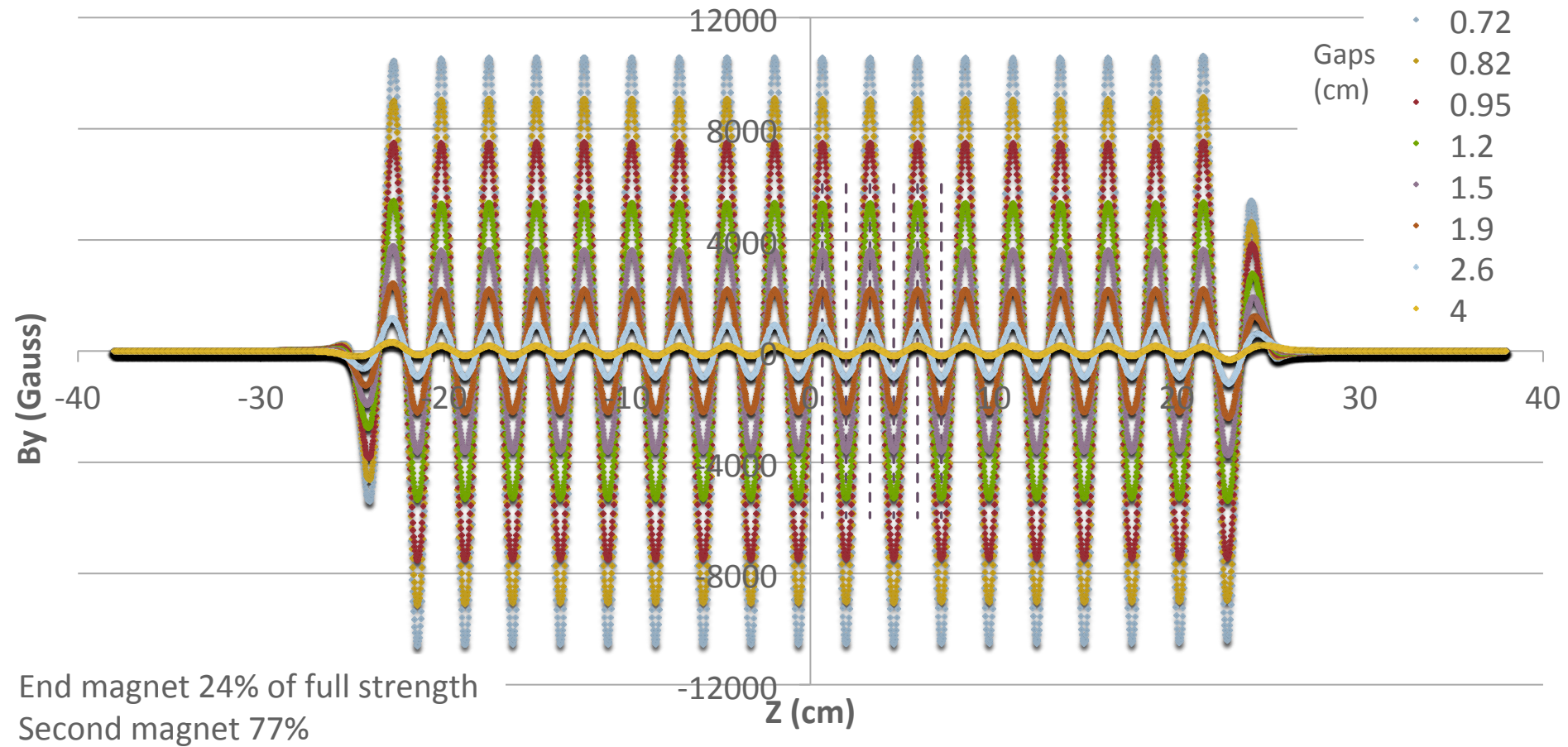

Trajectory is the 2nd integral; use it to find traj angle

- The angle of photon emission is the angle of the average trajectory in the main part of the undulator.
- Fitting all the trajectory points to a straight line is too sensitive to where the 'main part' starts & stops, so instead use the peaks in the trajectory and omit 5 poles at each end (the standard we use for phase error determination).

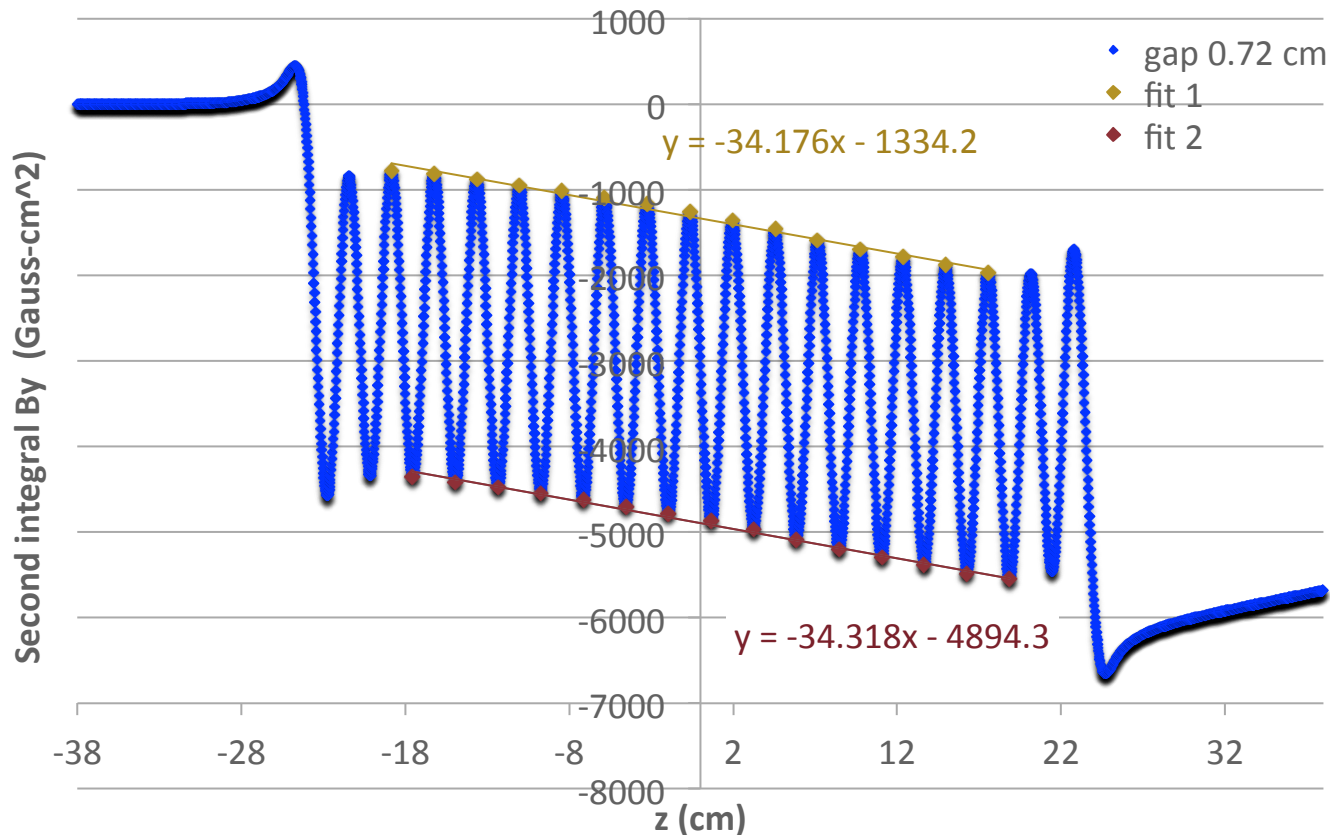

Look at trajectory angle vs. gap (40 poles)

Finding the trajectory angle was repeated for a variety of gaps, shown below. Some further refinement may be possible.

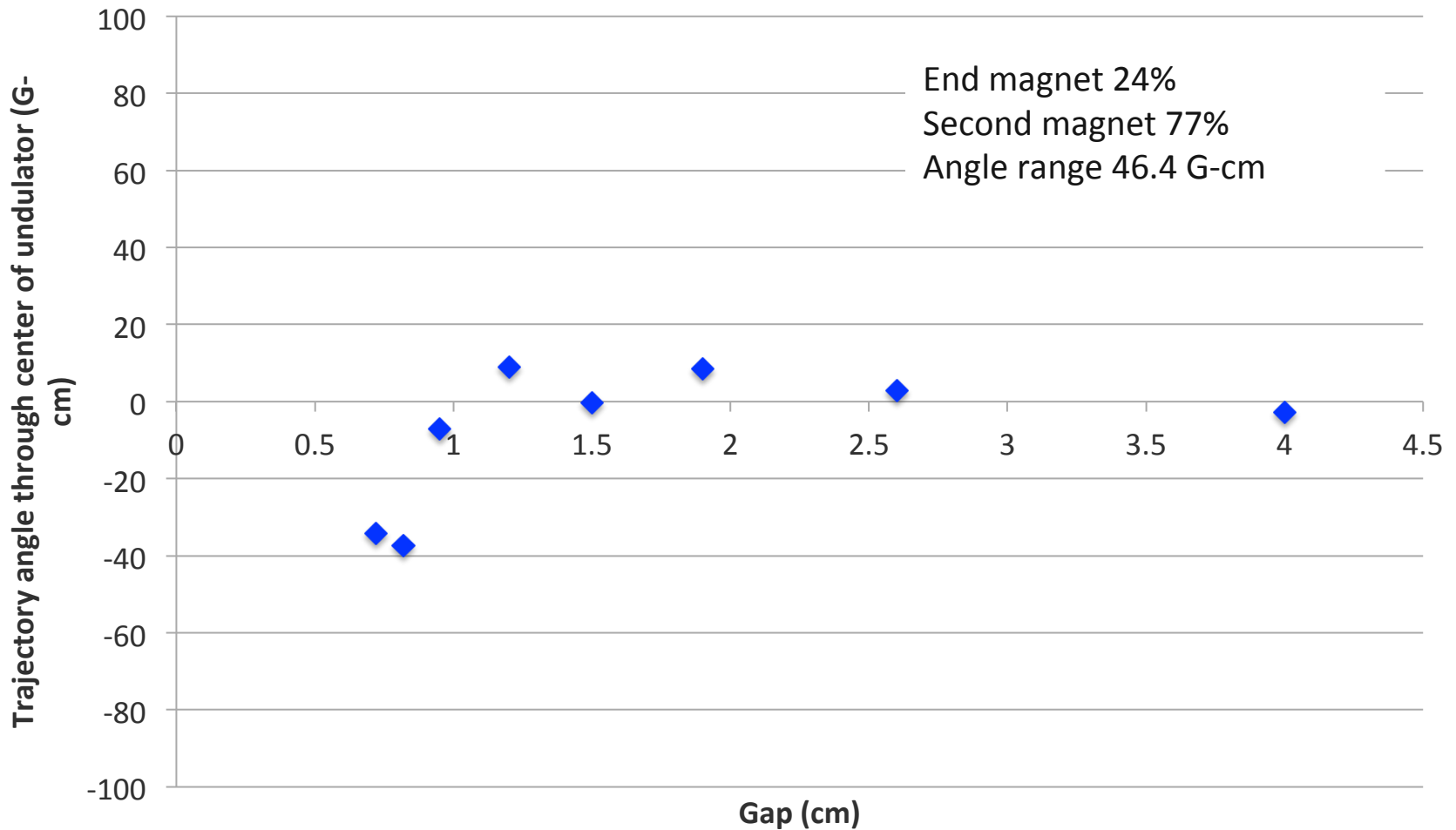

Comparison for different length undulator models

- Repeated the calculation with 20 poles at minimum gap only and 40 poles vs gap.
- From that, decided on 30 poles to refine the end pole strengths.

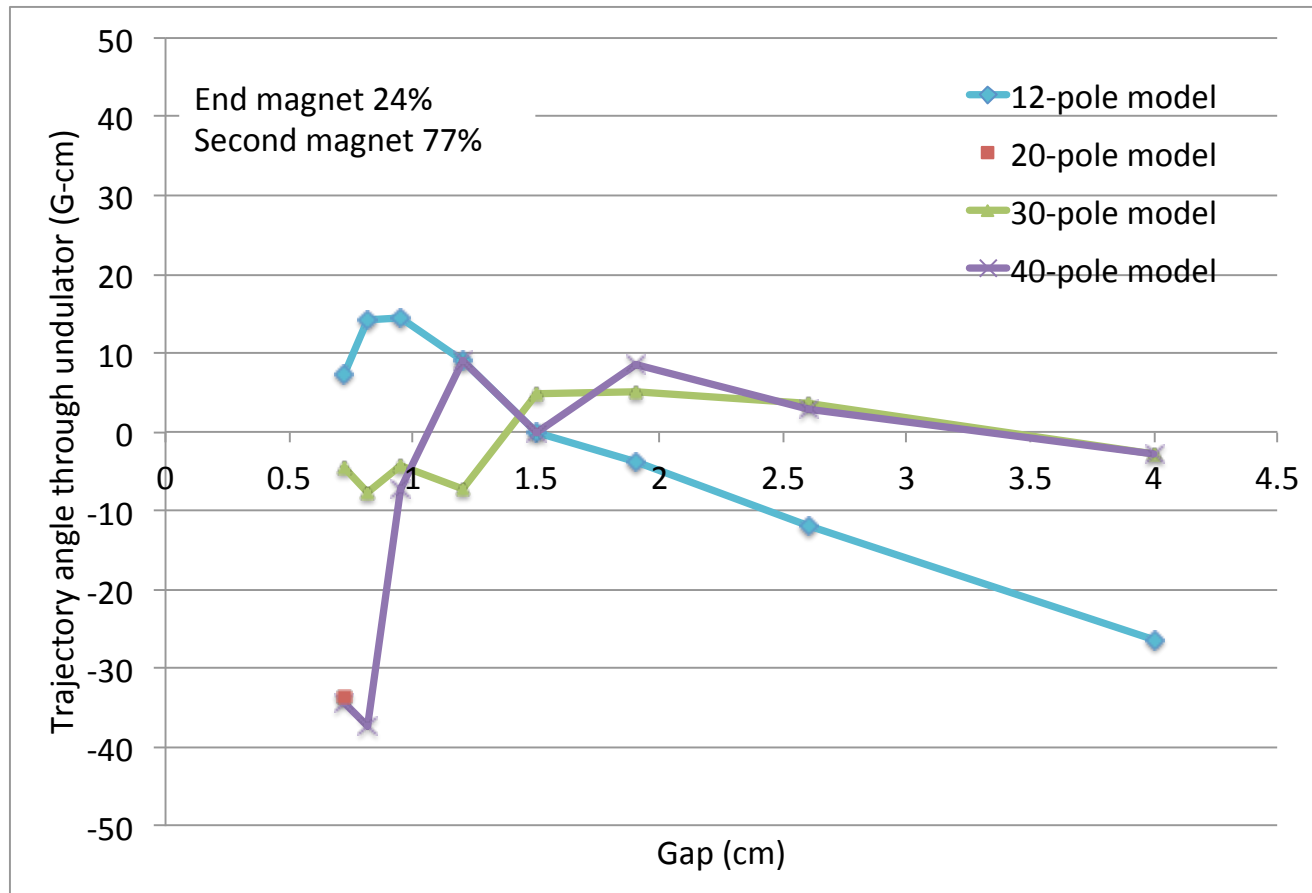

Consider end magnets with 30-pole model and in steps of 1% in strength

- The 24% / 77% end magnet strengths looks good, but see whether the optimum is slightly different with a longer model.
- Also, with smaller steps in magnet strength, see if it can be refined further. Also will give a feeling for tolerances.
- Ran a new series of calculations with end magnet strengths of 22, 23, 24, 25, and 26%, and with next-to-end magnet strengths of 75, 76, 77, 78, and 79%.

30-pole model results (constant next-to-end magnet)

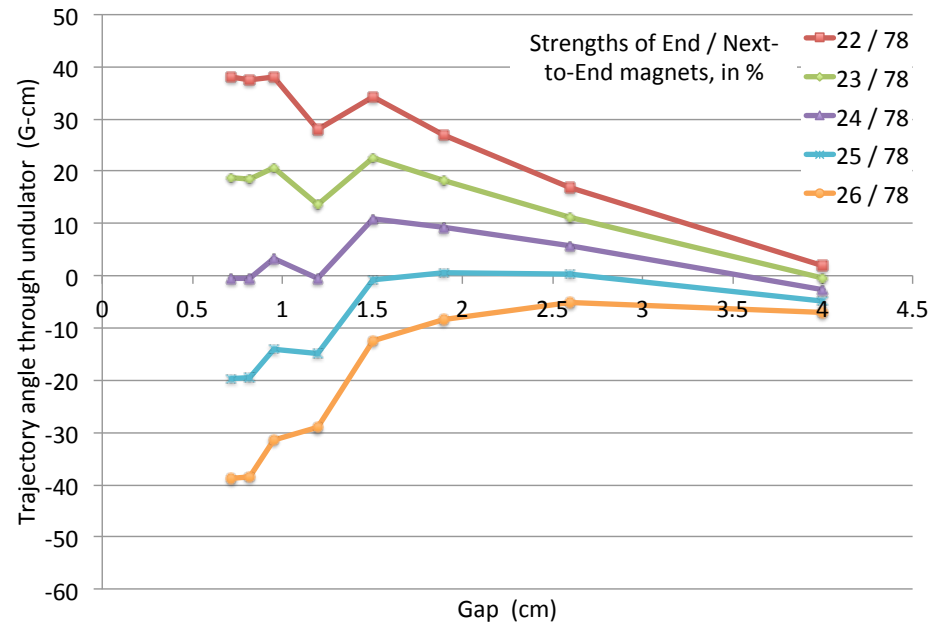
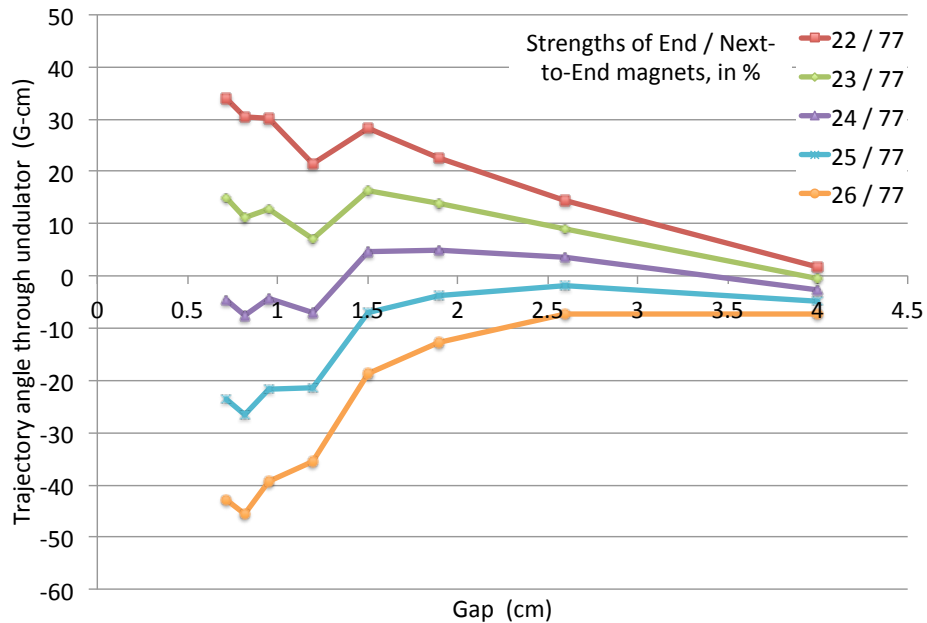
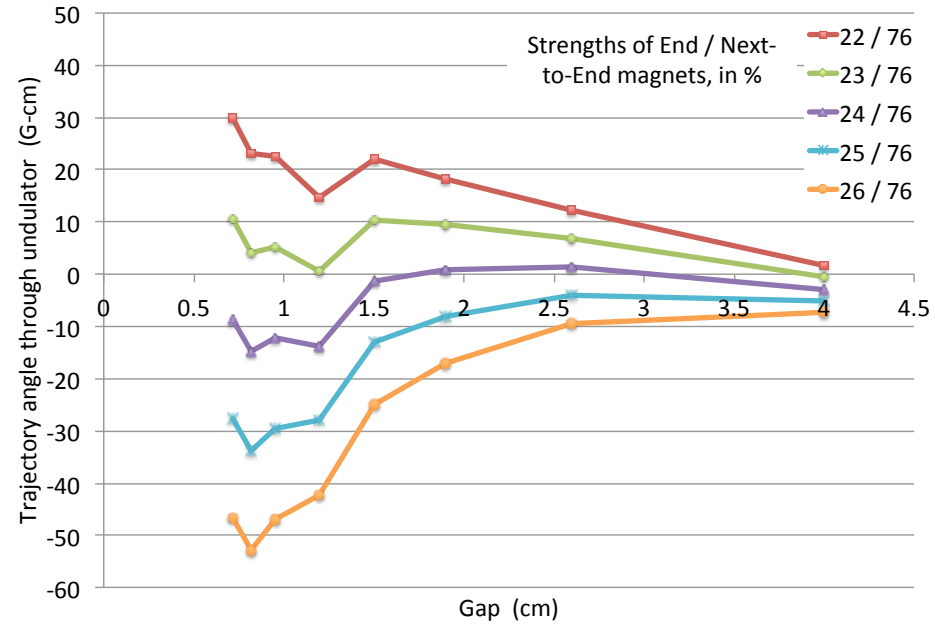
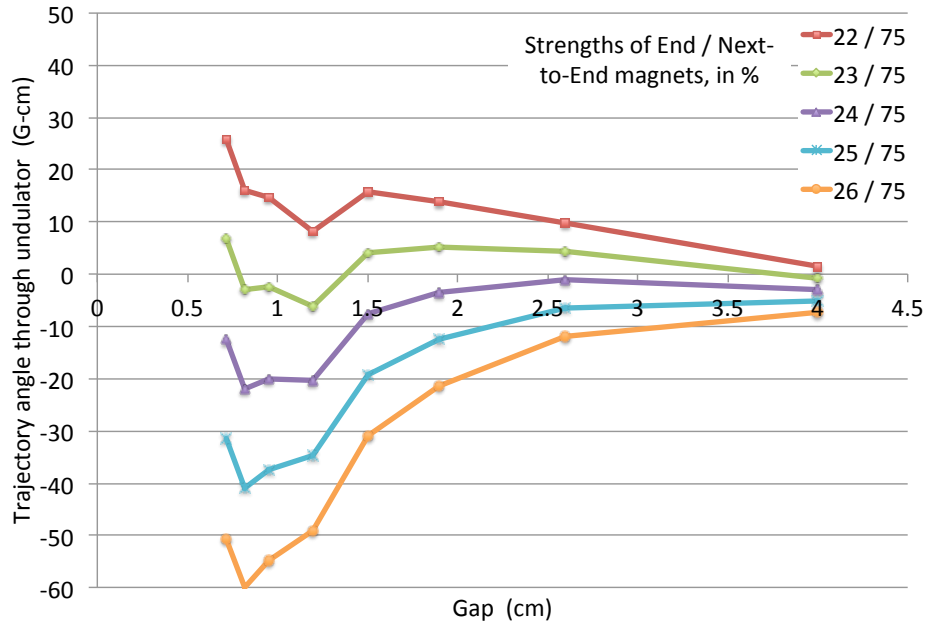

30-pole model results, cont.

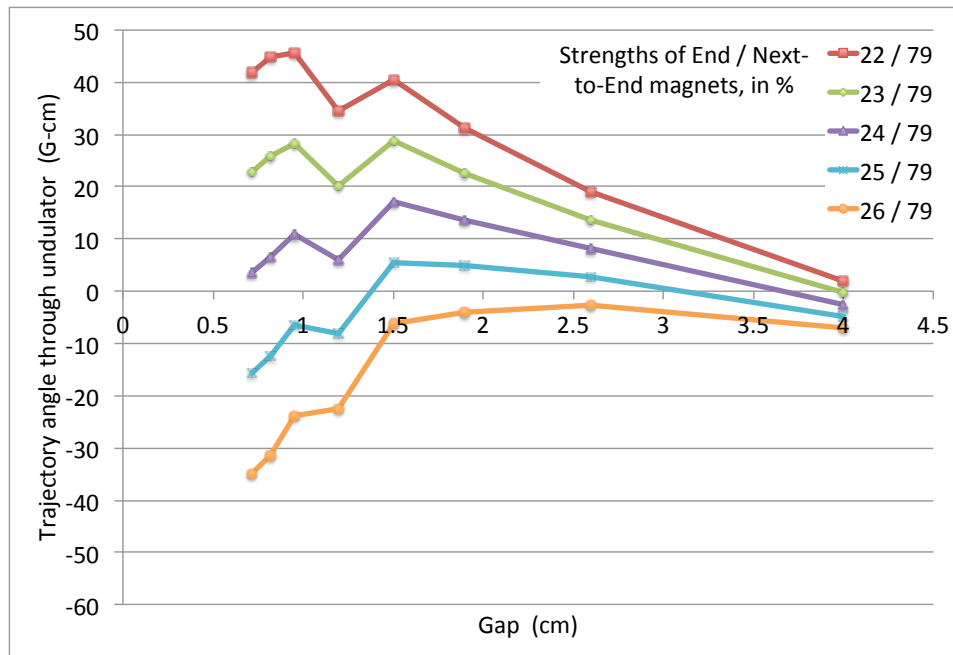

- Considerations for choice:
 - Seeking a flat gap dependence at small gaps leads to a choice of 77 or 78% for the next-to-end magnet.
 - A small variation in angle over the gap range, while bracketing zero, leads to 24%.
 - 23% or 25% give slightly larger range in angle along with a shift in angle.
 - 76% or 78% give the same range in angle but result in a shift in angle.



30-pole model results (constant end magnet)

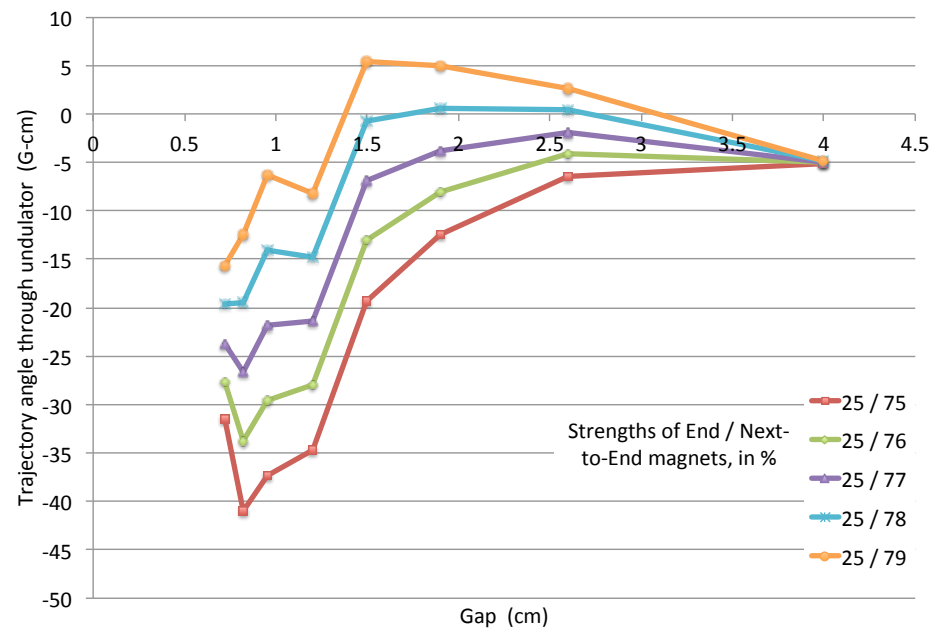
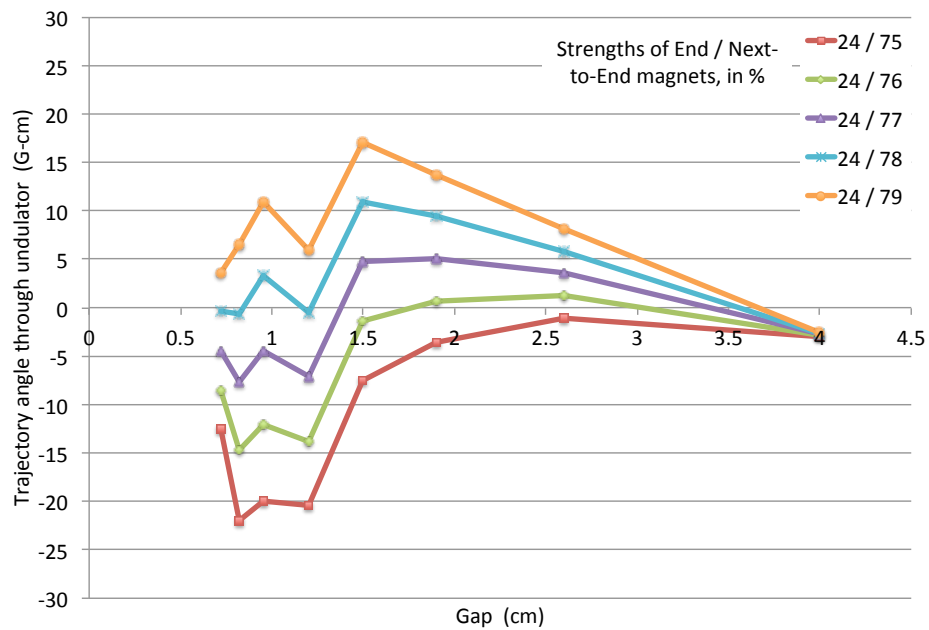
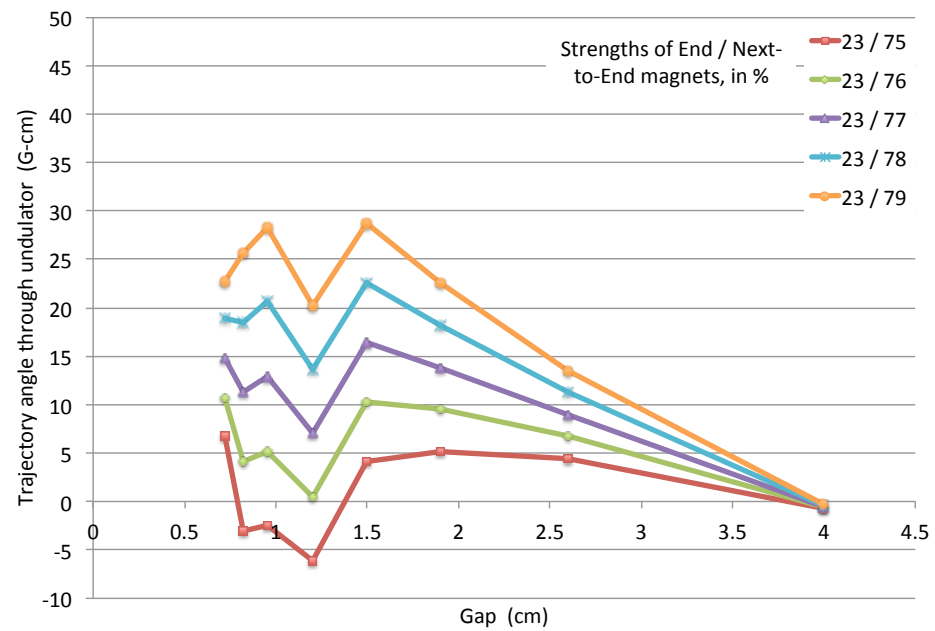
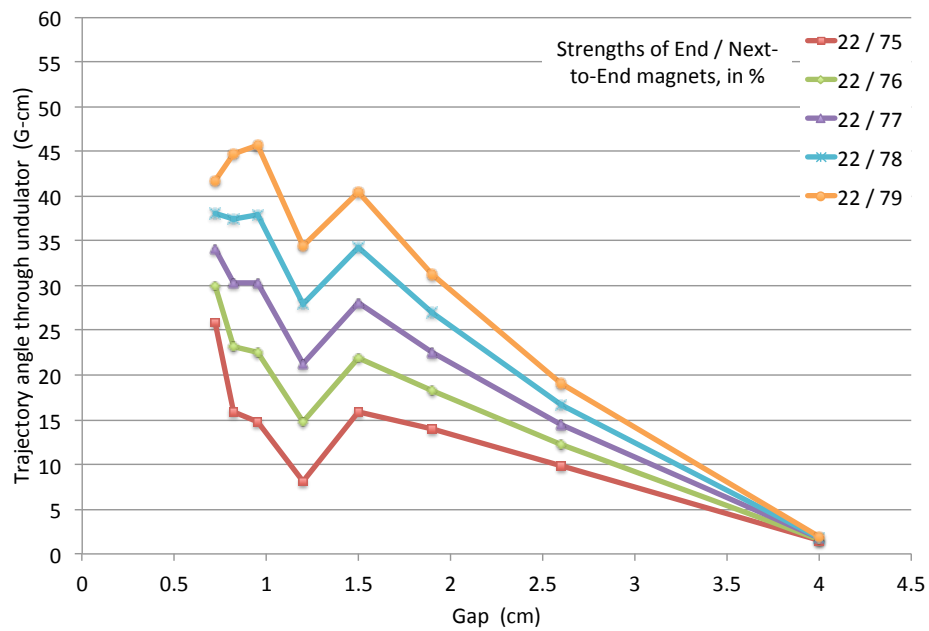

30-pole model results: another view, cont.

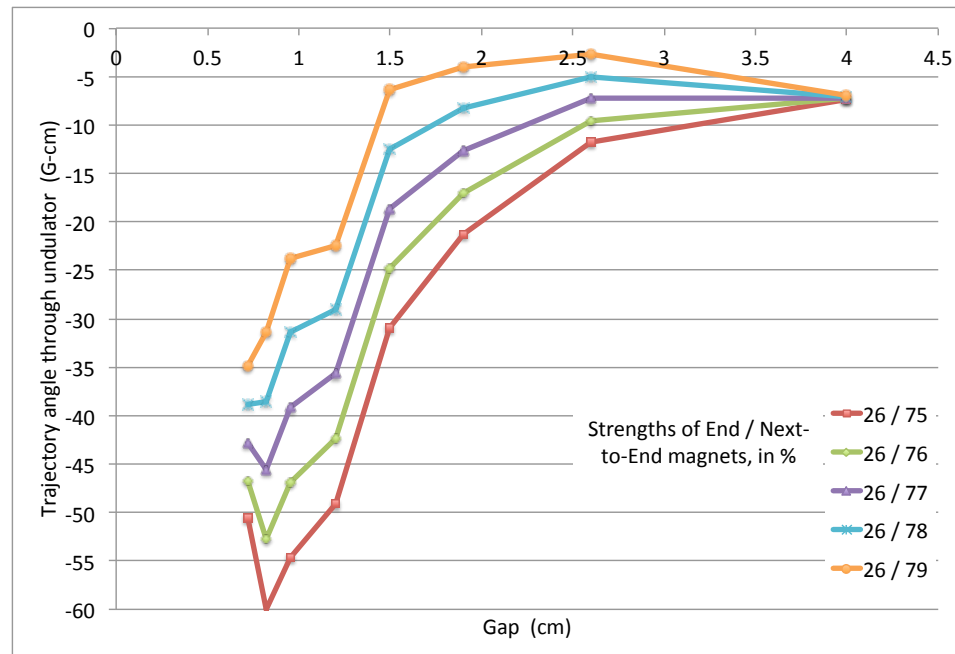

- Considerations for choice:

- Trajectory angles for a given end magnet strength all converge to (nearly) the same value at 4 cm gap.
- Could choose the one closest to zero, i.e. 23%. To bracket zero, second magnet would be 75%.
- But: trajectory angle changes rapidly at small gaps for 23/75. 24/77 seems a quieter choice but the difference isn't huge.



Field at end of undulator with 24%/77% magnets

- End of last pole is 25.6075 cm. Model has 40 poles.

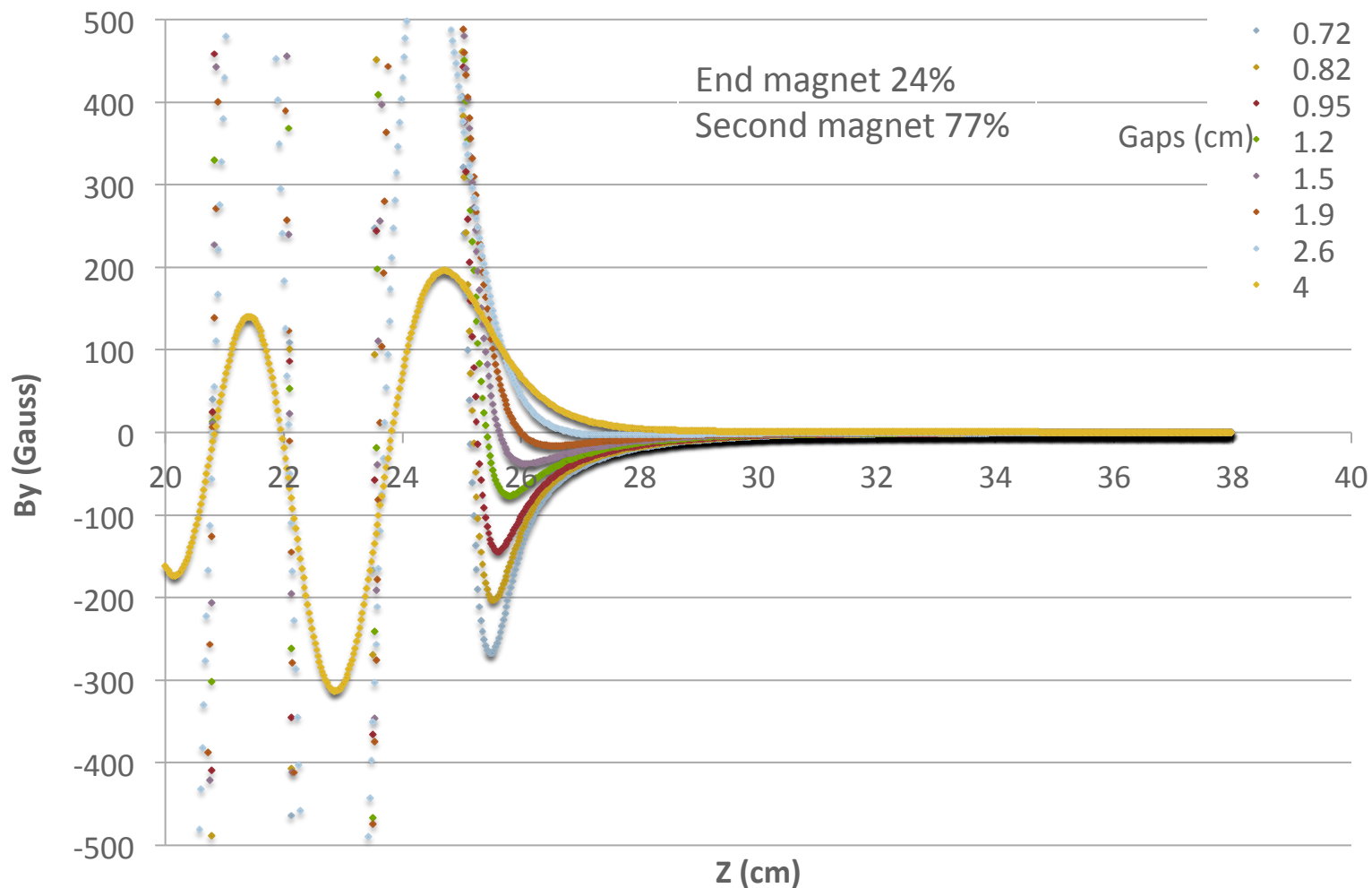

Field at end of undulator with 24%/77% magnets

- End of last pole is at 25.6075 cm. Field is below 10G at $z \geq 28.9$ cm for all gaps.

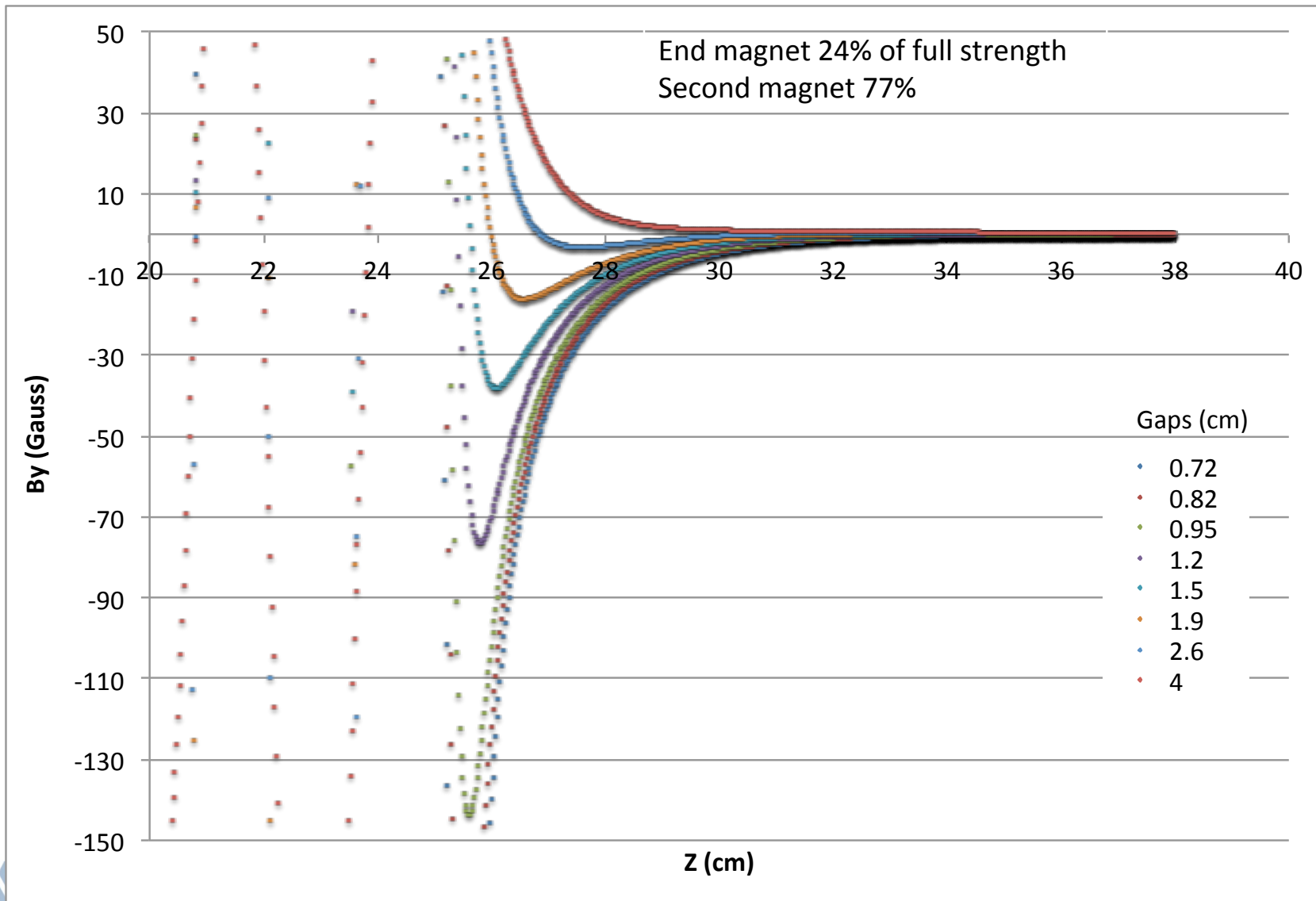

Distance field extends beyond undulator end

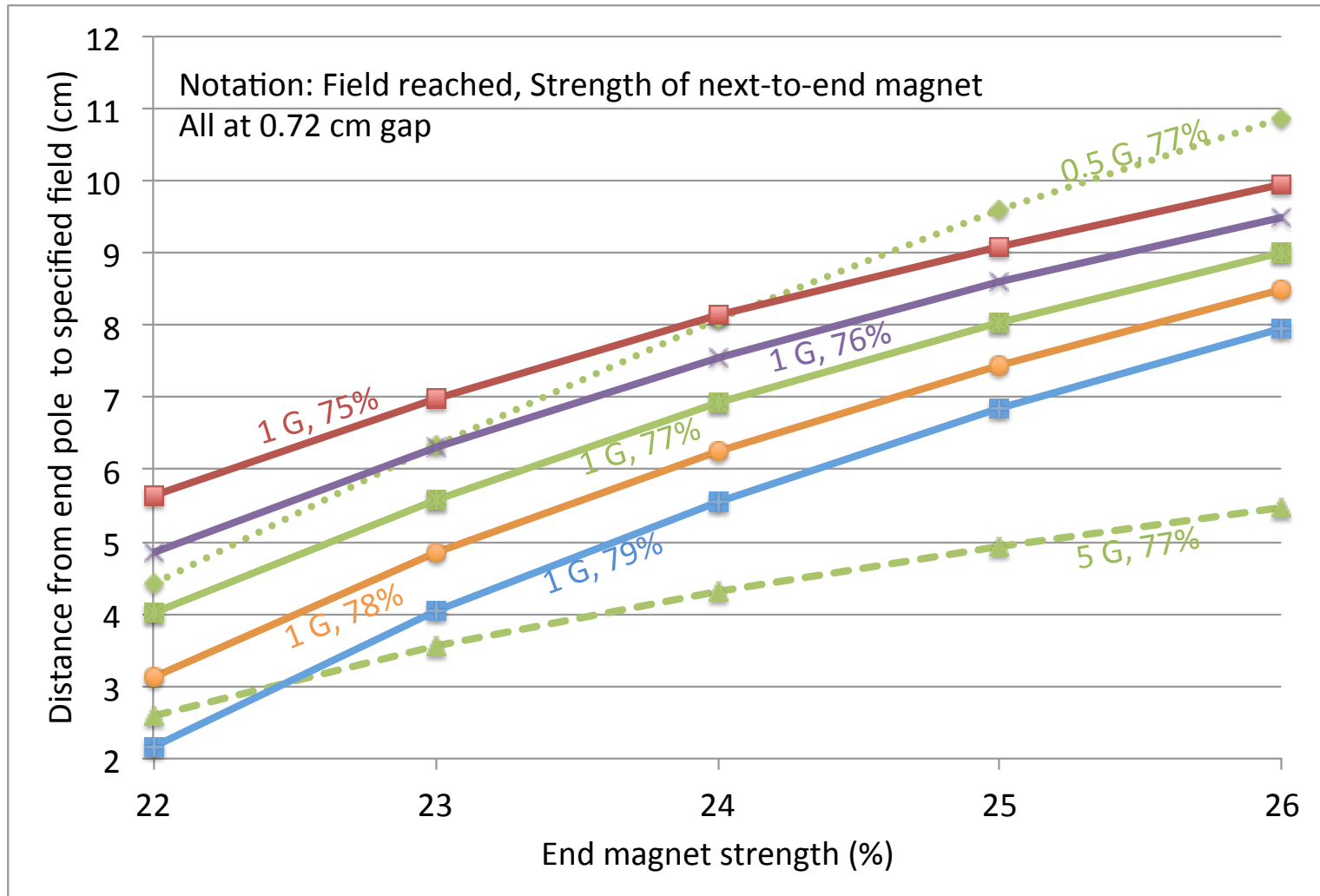

Field extends farther for stronger end magnet, and for weaker next-to-end magnet.

Phase shifter model (in Opera3D)

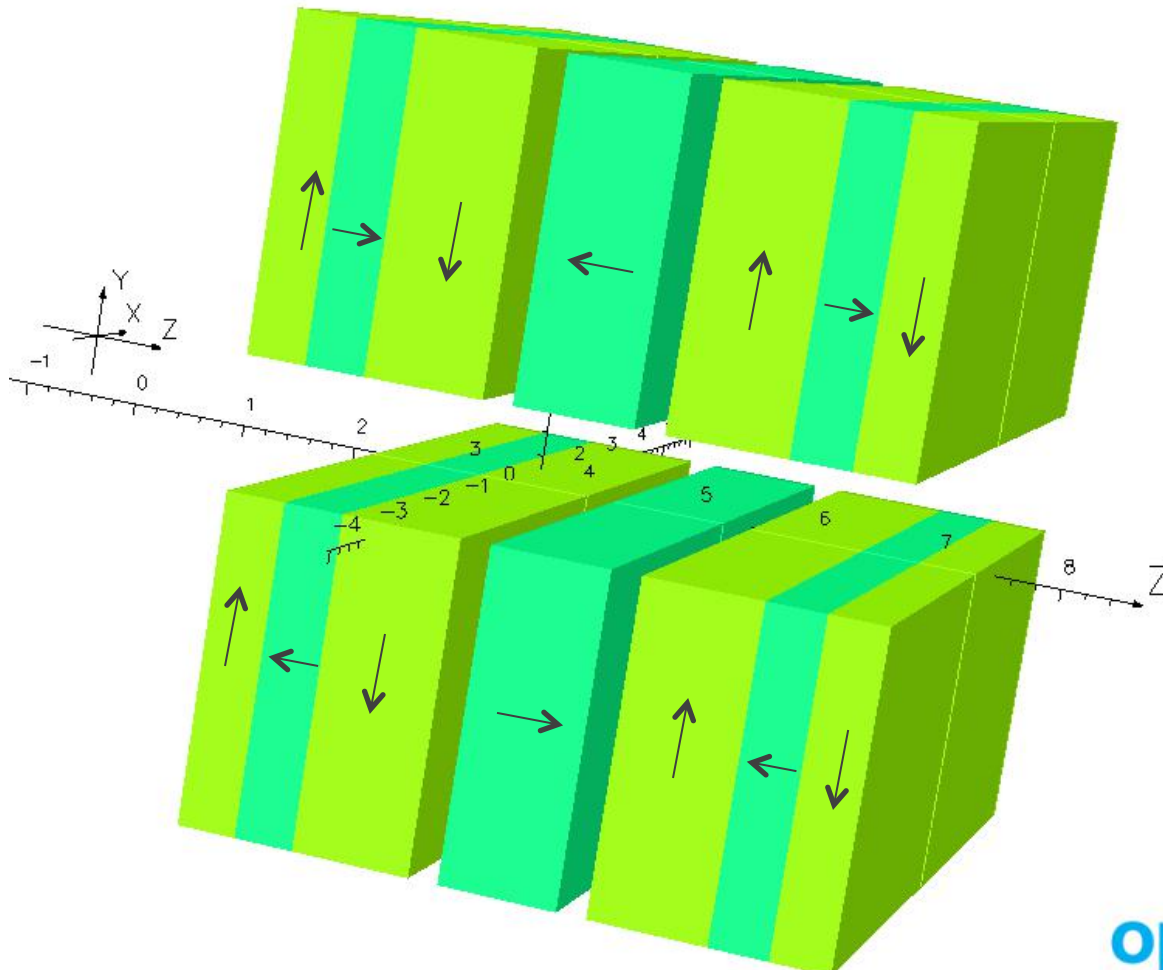

op

- This is the HXR phase shifter as given in the Physics Requirements Document for the Undulator Phase Shifter, Doc No. LCLSII-3.2-PR-0105-R0
- Grade of permanent magnets is Shin-Etsu N42SH, with $B_r=1.27$ T and $H_{CB}=12000$ Oe. ($H_{CJ}=21000$ Oe)

On-axis field from phase shifter at different gaps

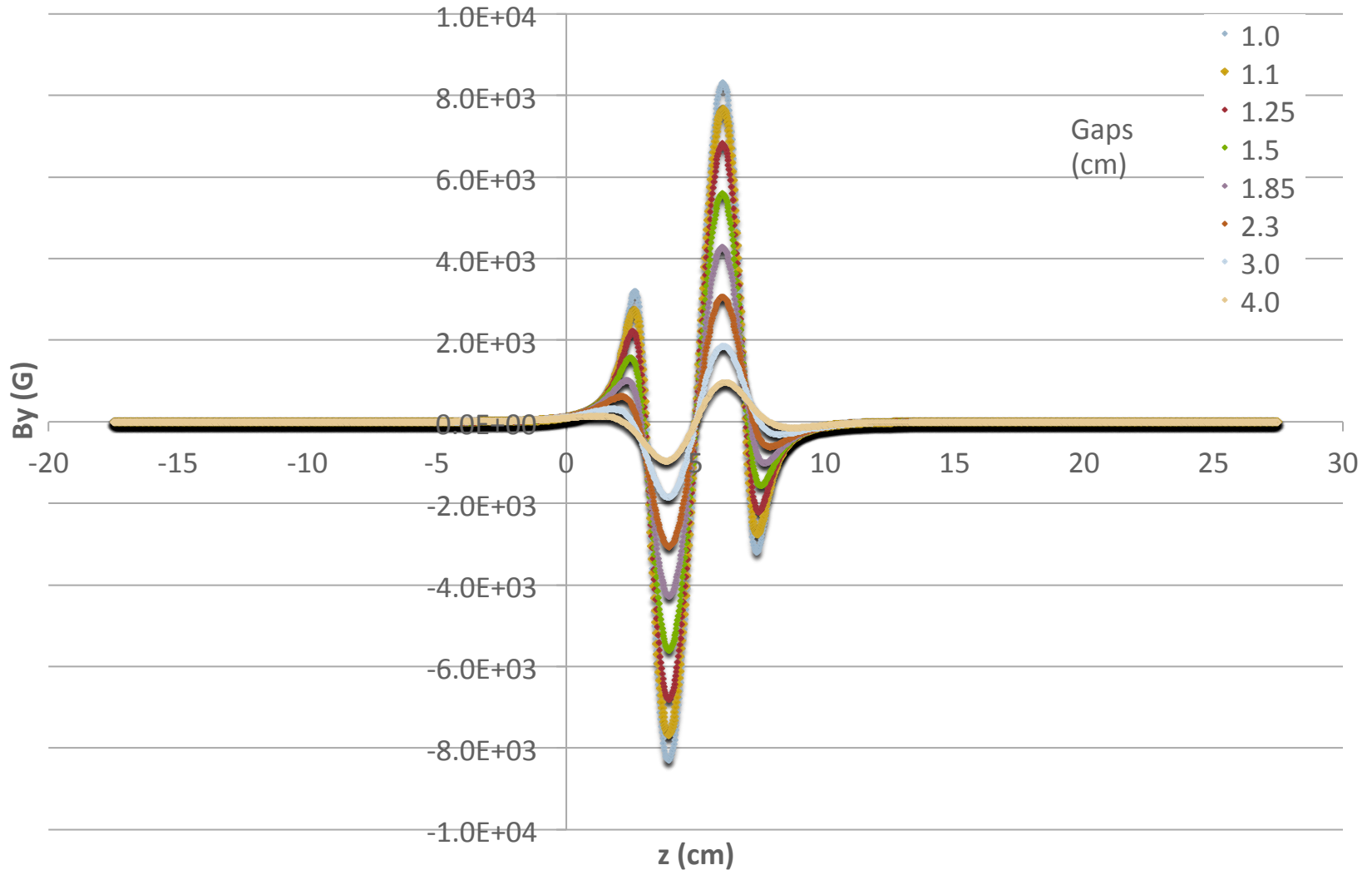

Phase integral through shifter at several gaps

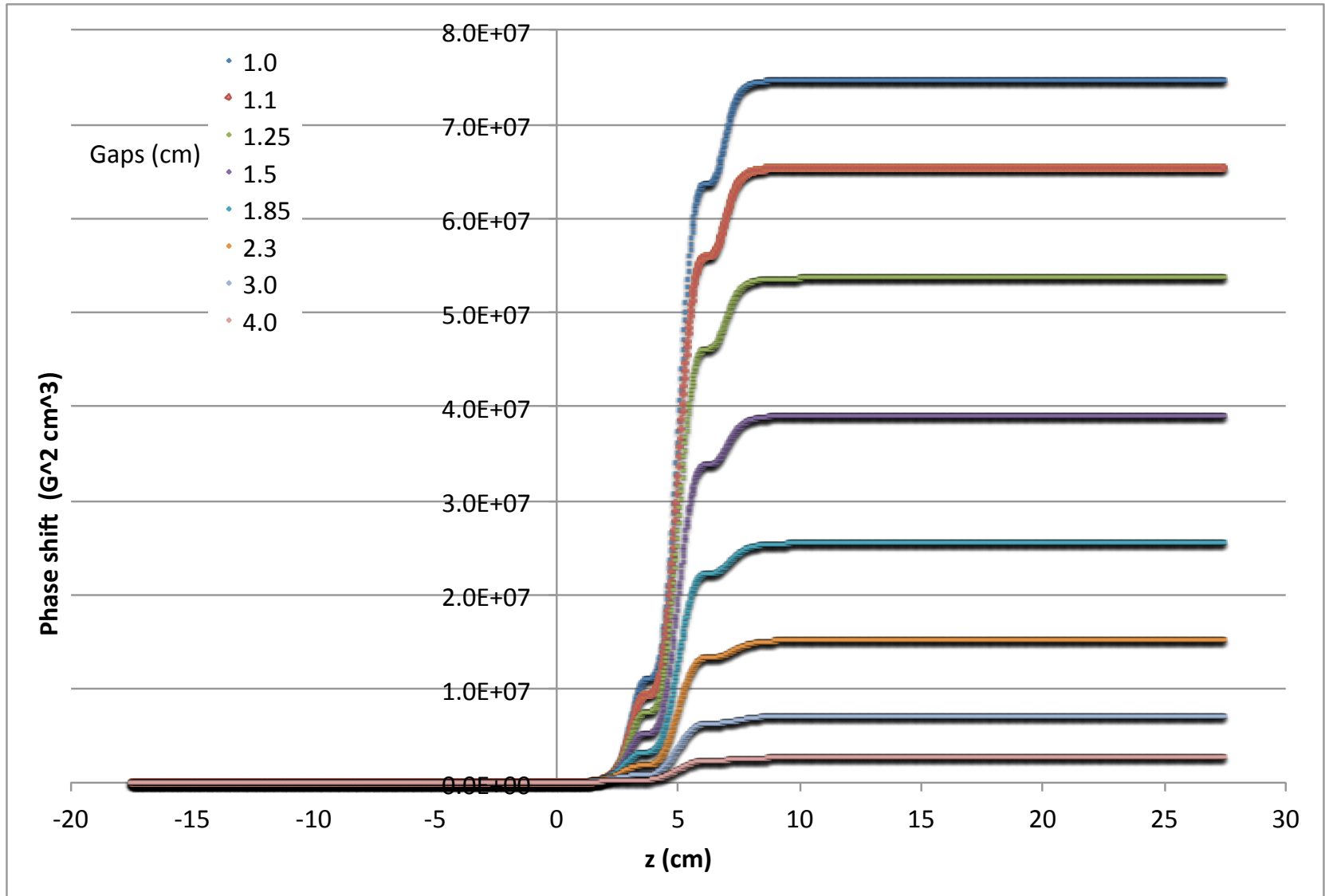

Phase integral through shifter vs. gap

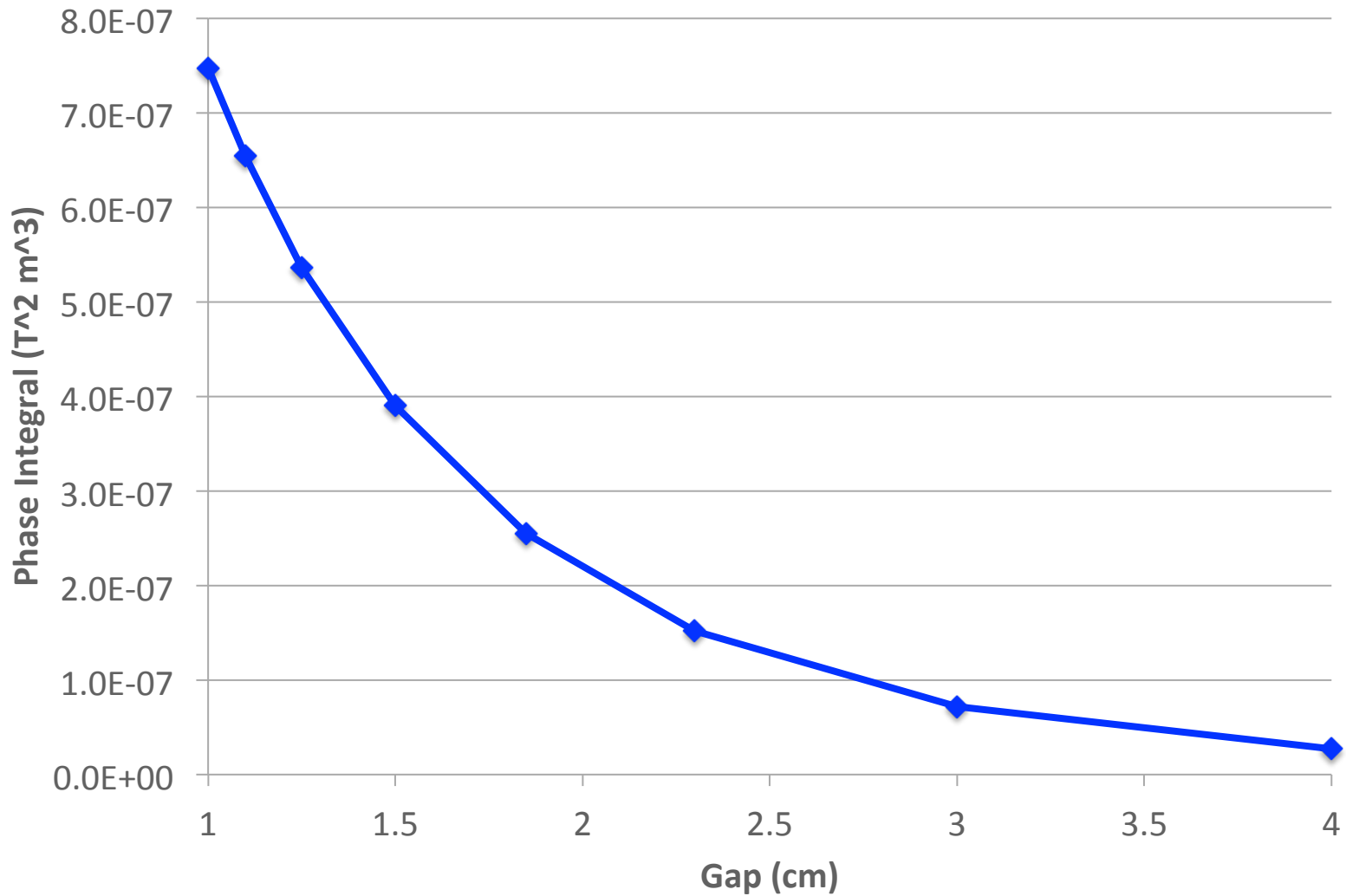

Force components on phase shifter magnets, in pounds

(Phase shifter gap is 10.0 mm)

Direction of force component	Magnet 1	Magnet 2	Magnet 3	Magnet 4	Magnet 5	Magnet 6	Magnet 7	Sum of Magnets 1-3	Sum for whole jaw
X	0	0	0	0	0	0	0	0	0
Y (gap) *	-23.7	51.7	-84.2	35.1	-84.2	51.7	-23.7	-56.0	-78.0
Z (beam)	9.1	-10.9	-9.3	0.0	9.3	10.9	-9.1	-11.0	0.0

* Jaws are attracting when y is negative

Details:
Thin air spaces added for the force calculation. Results obtained by different methods agreed to ~5%.

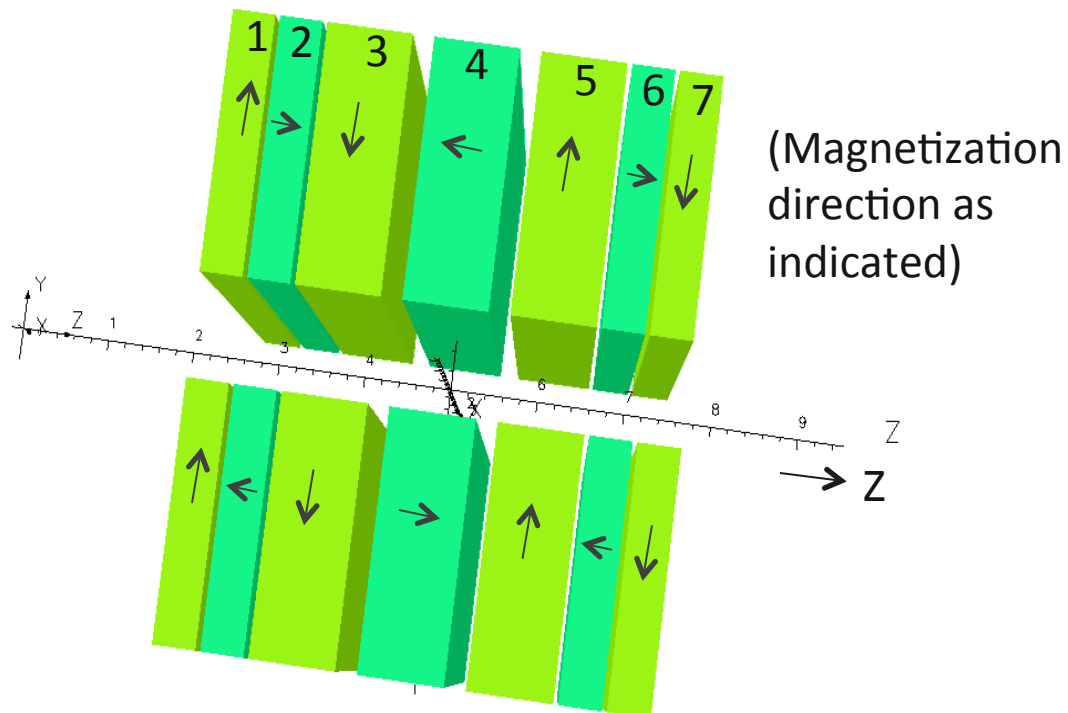

Combined model

3/Sep/2014 14:45:33

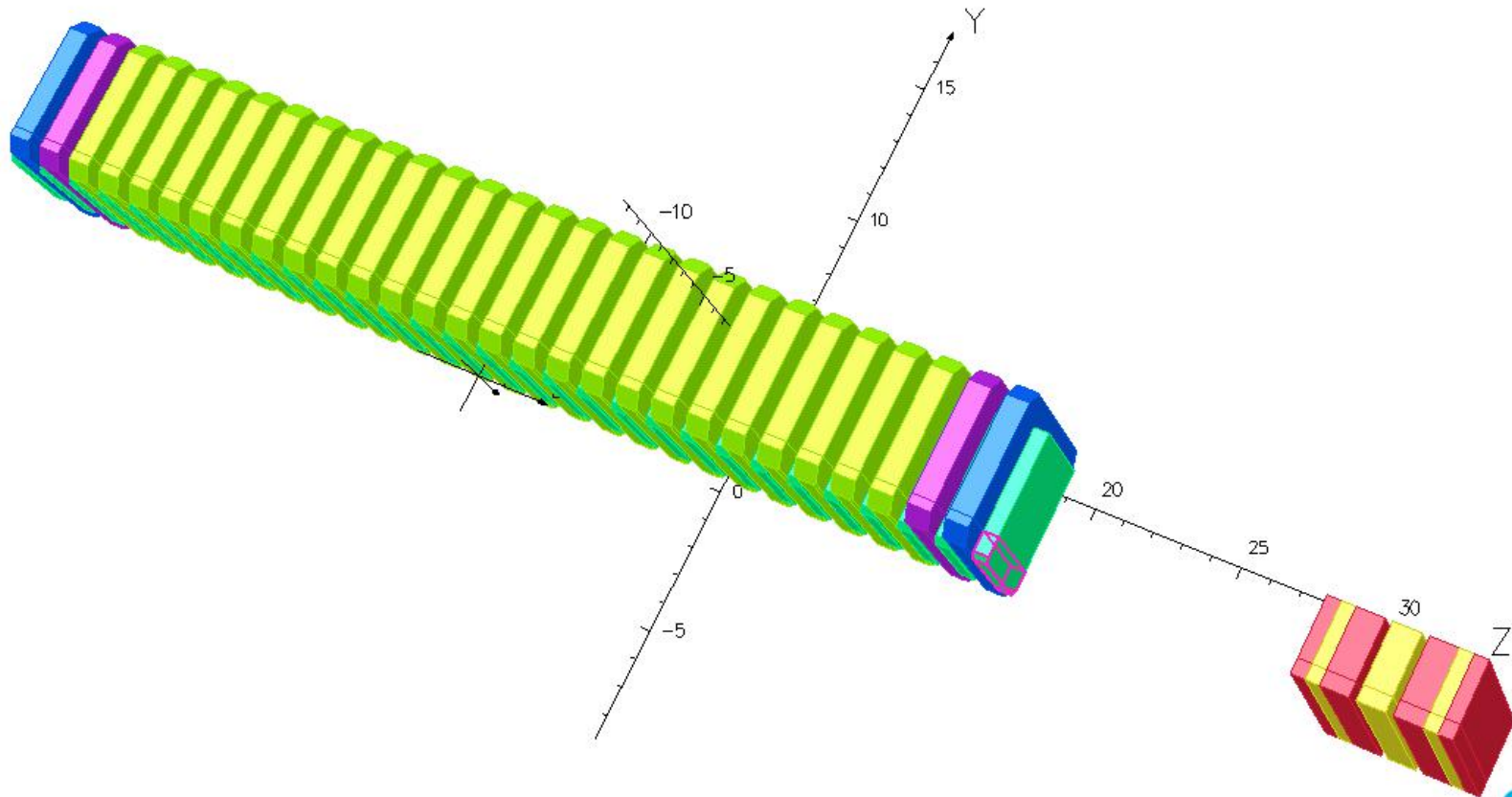

opera
simulation software

Space at end of Und.

- Sketch showing the end of the undulator, the phase shifter, and the adjacent quadrupole magnet. (Also includes a collimator which may be removed from the plan.)
- Space between undulator end and face of quad shield is 253.23 mm.
- Phase shifter is centered between the end of the last undulator pole and the beginning of the quadrupole shield.
- The gap-separation mechanism for the phase shifter is a placeholder. The final magnetic structure may be slightly longer to retain the magnet blocks that want to leave in the beam direction.

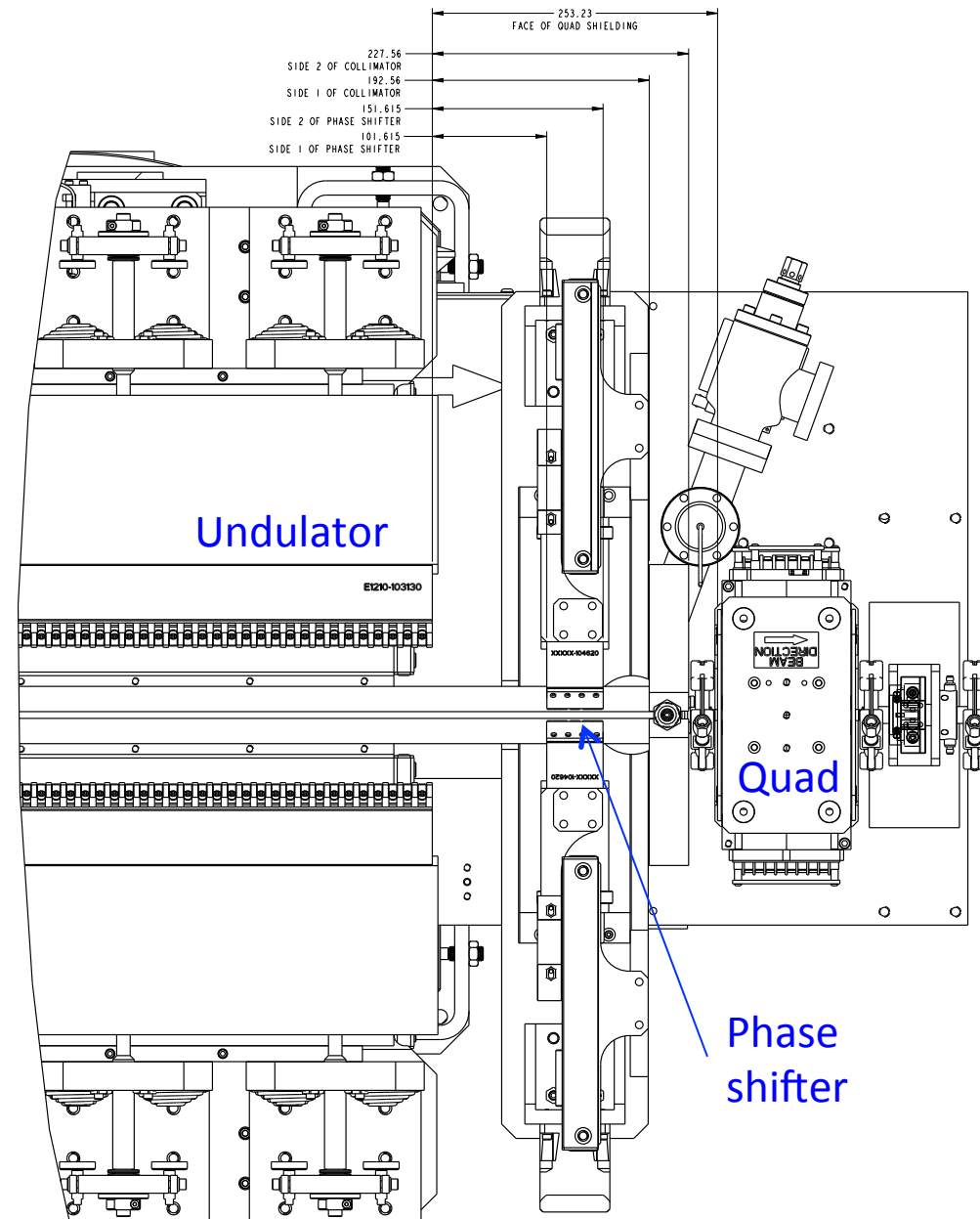

Combination of undulator and phase shifter

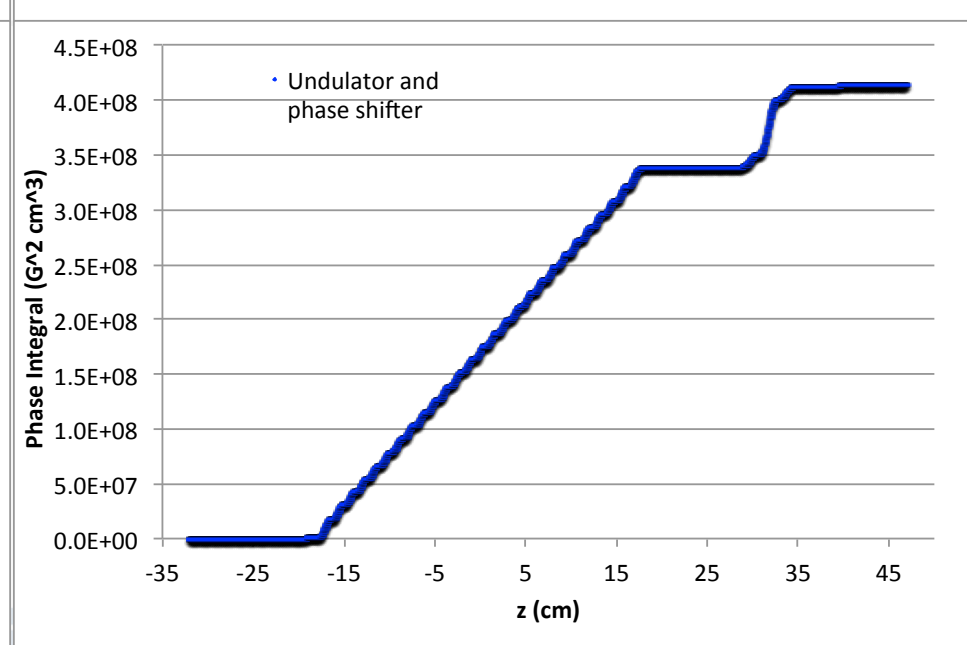
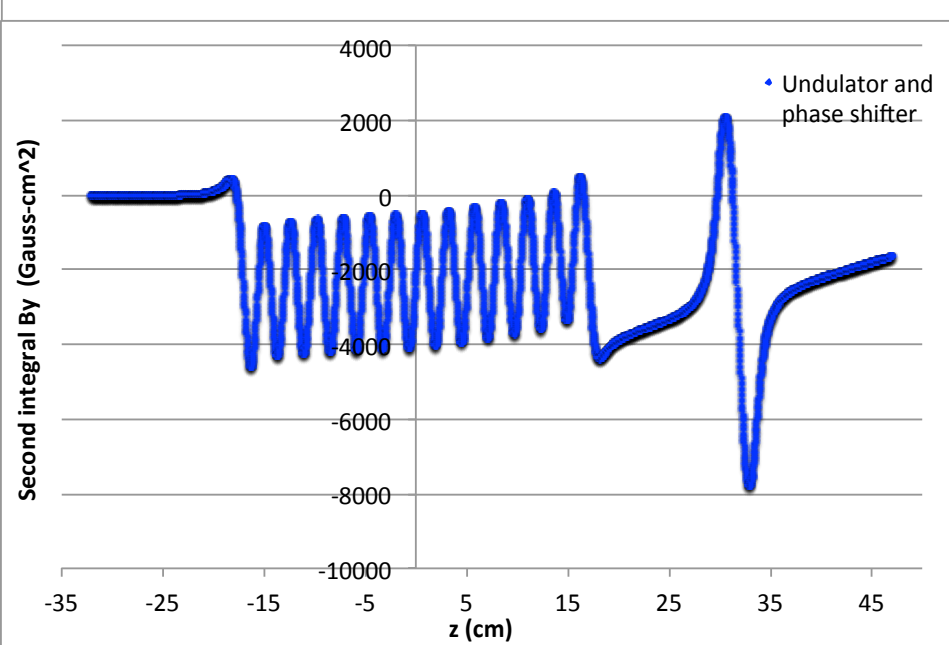
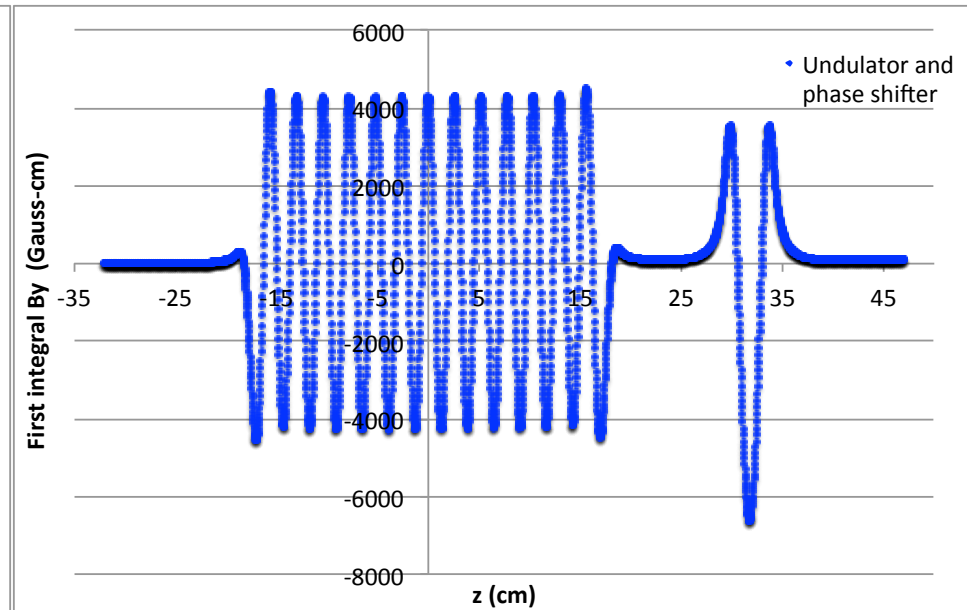
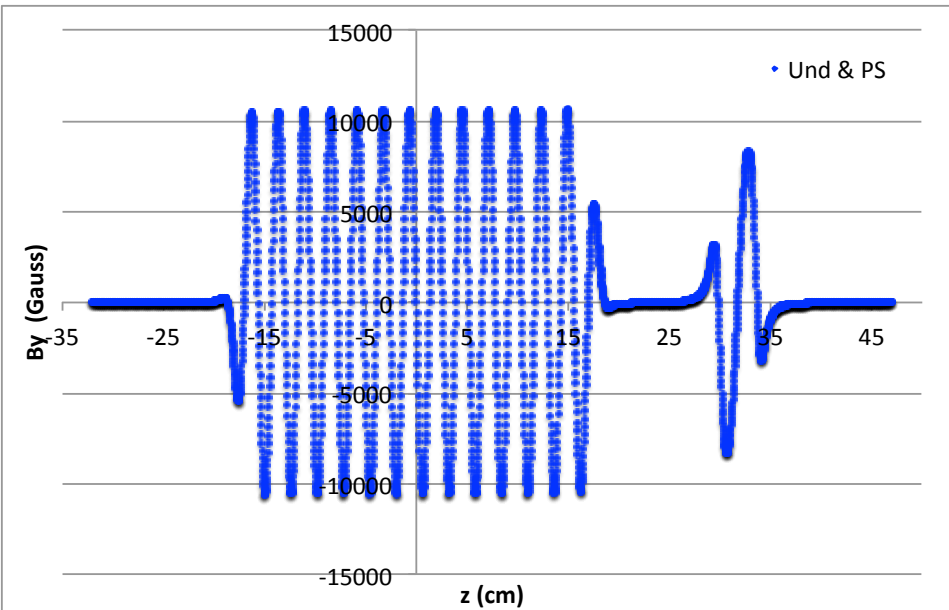

Undulator alone

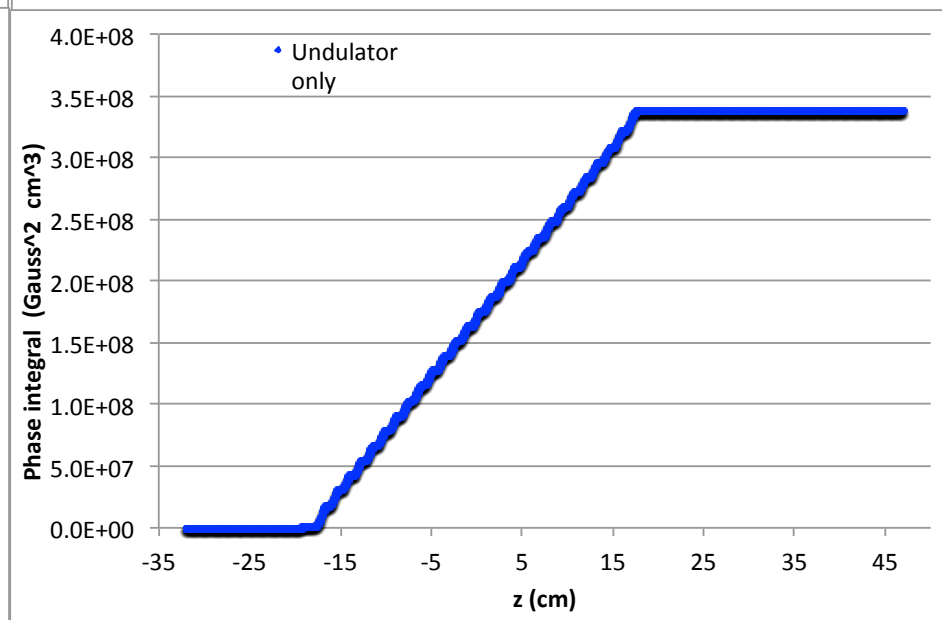
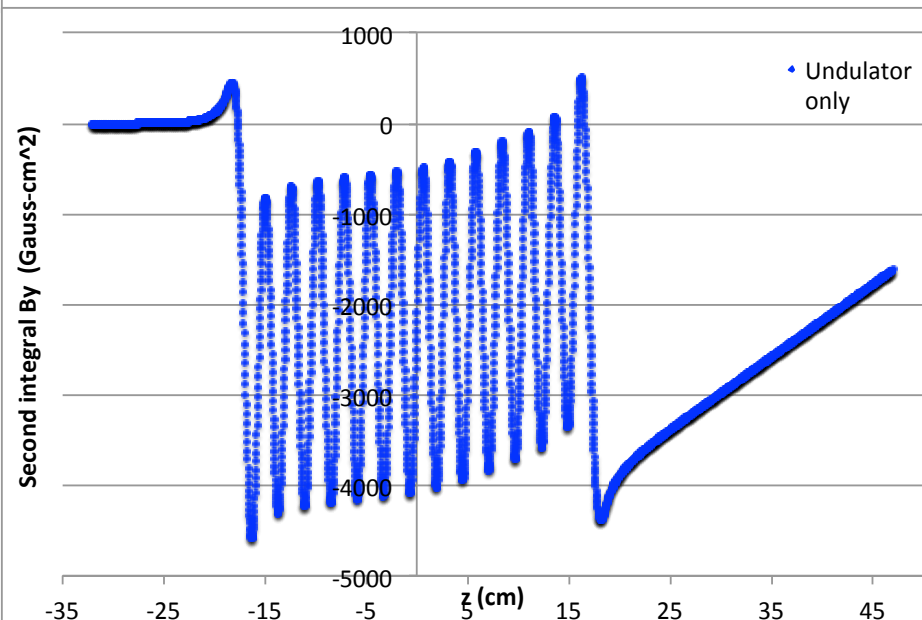
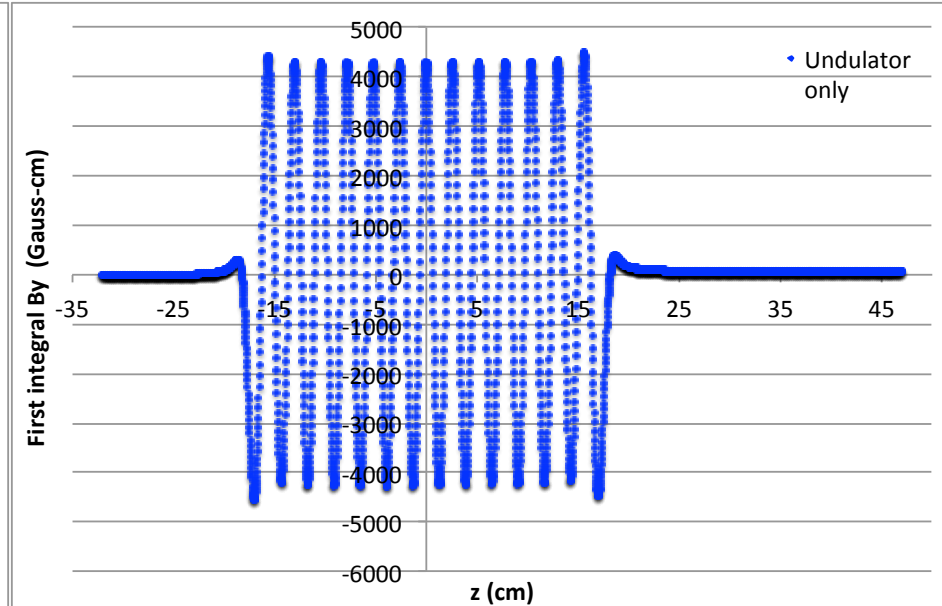
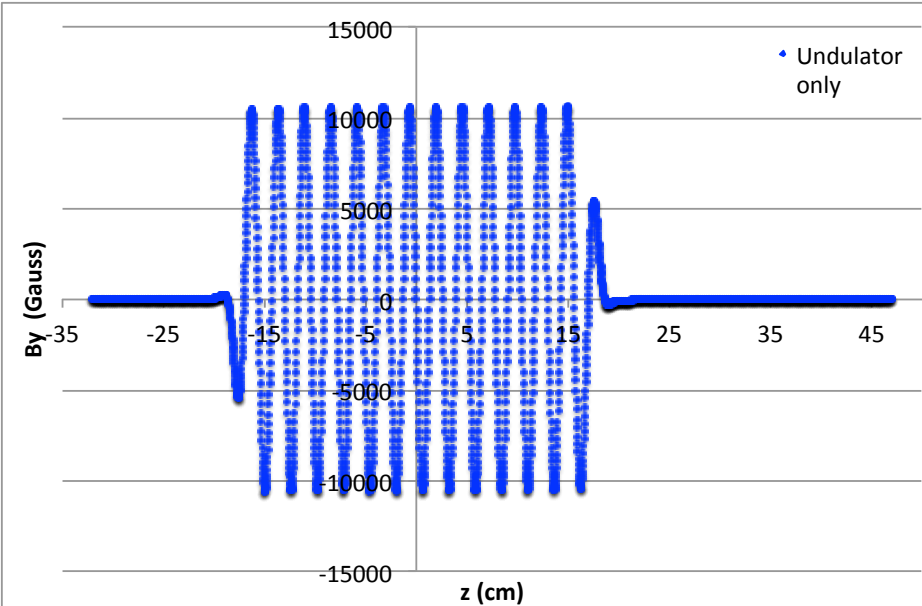

Phase shifter alone

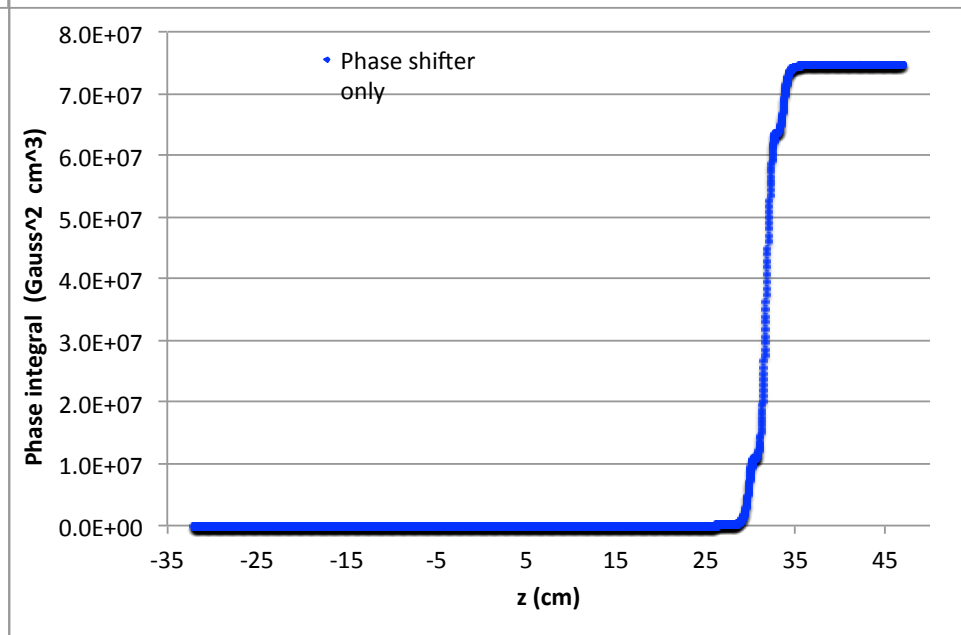
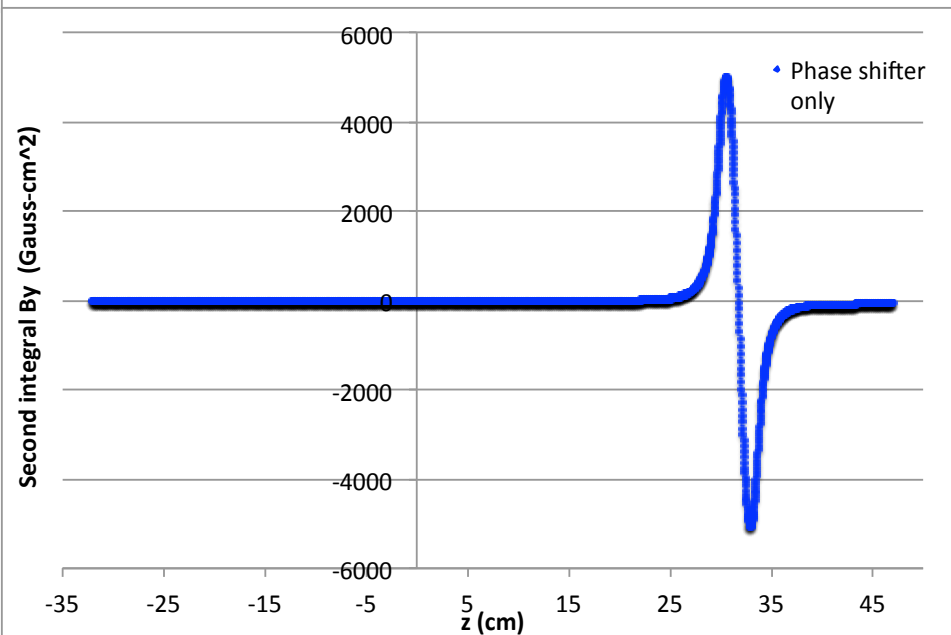
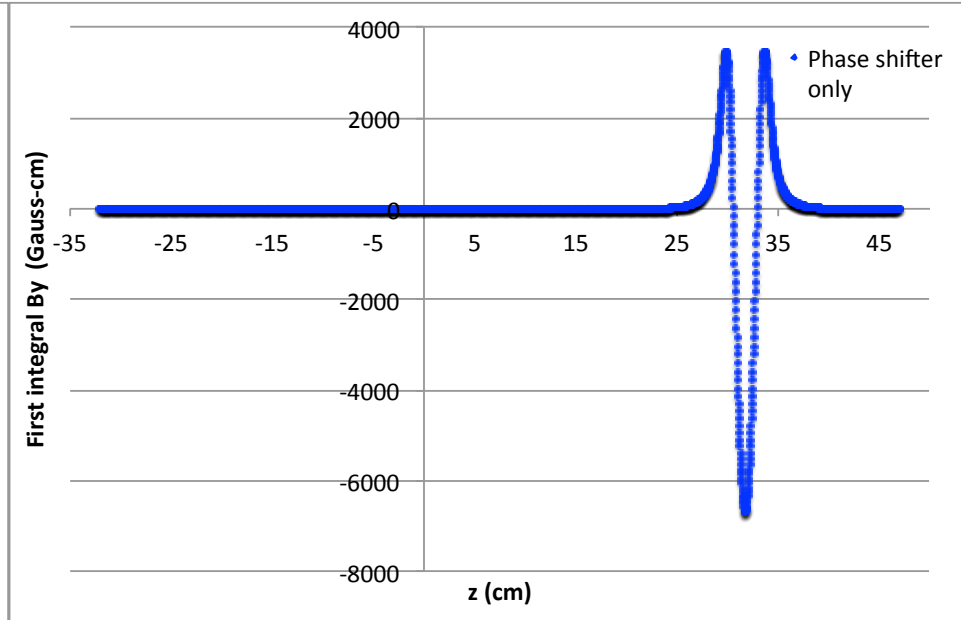
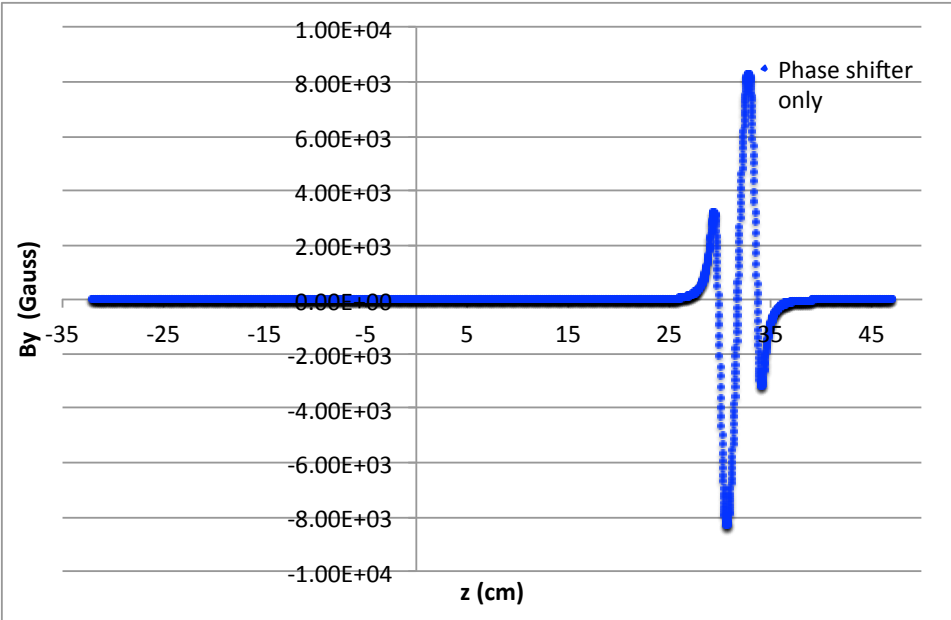

Sum of undulator alone + phase shifter alone

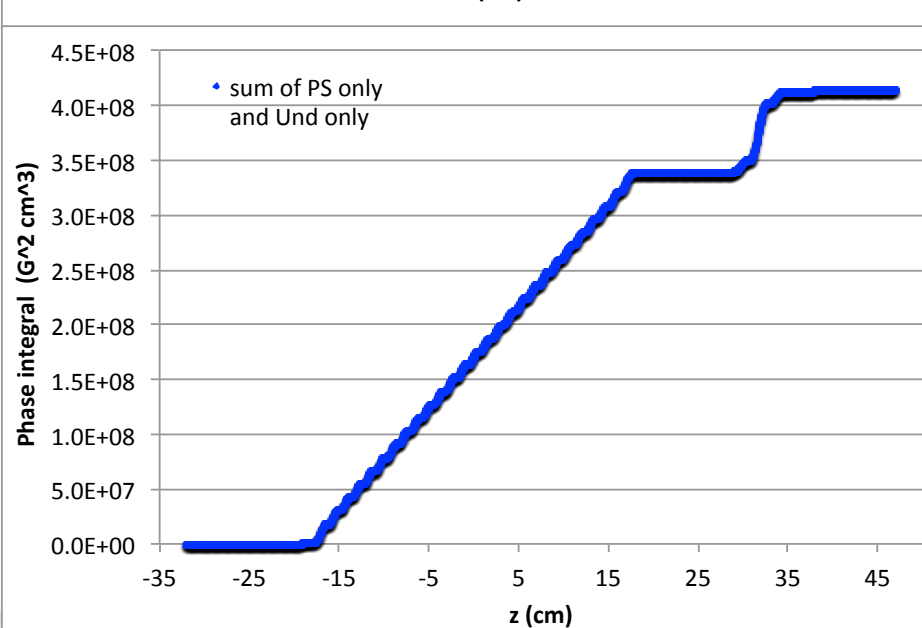
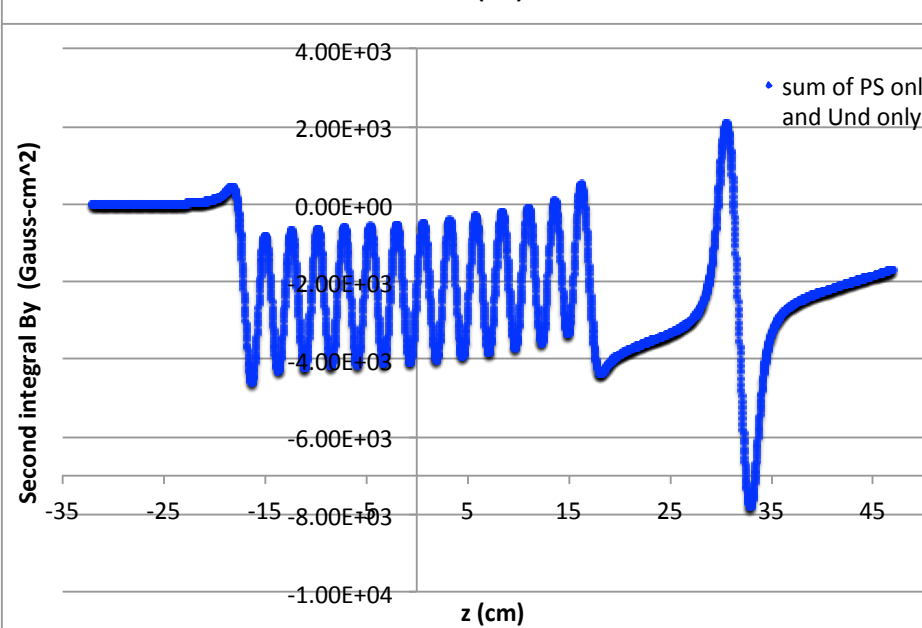
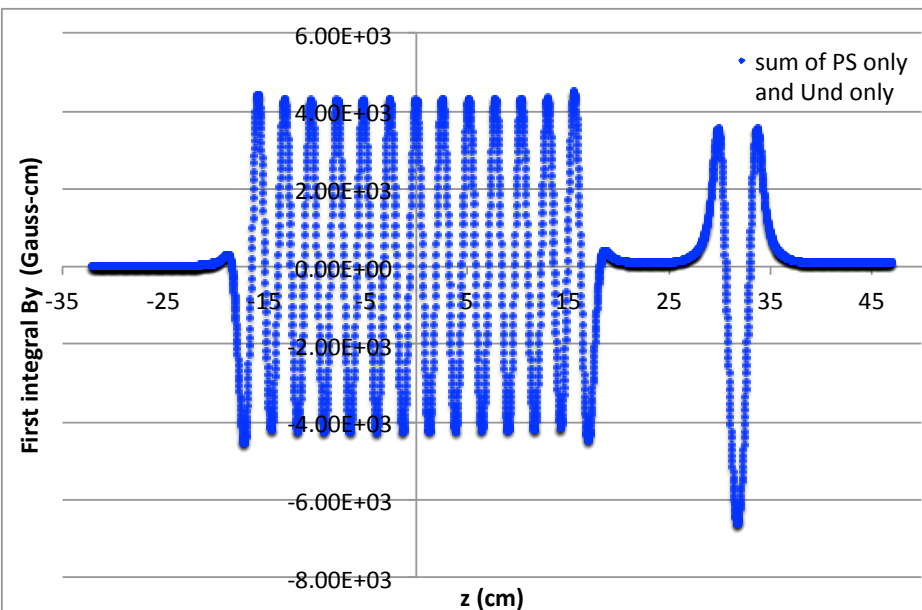
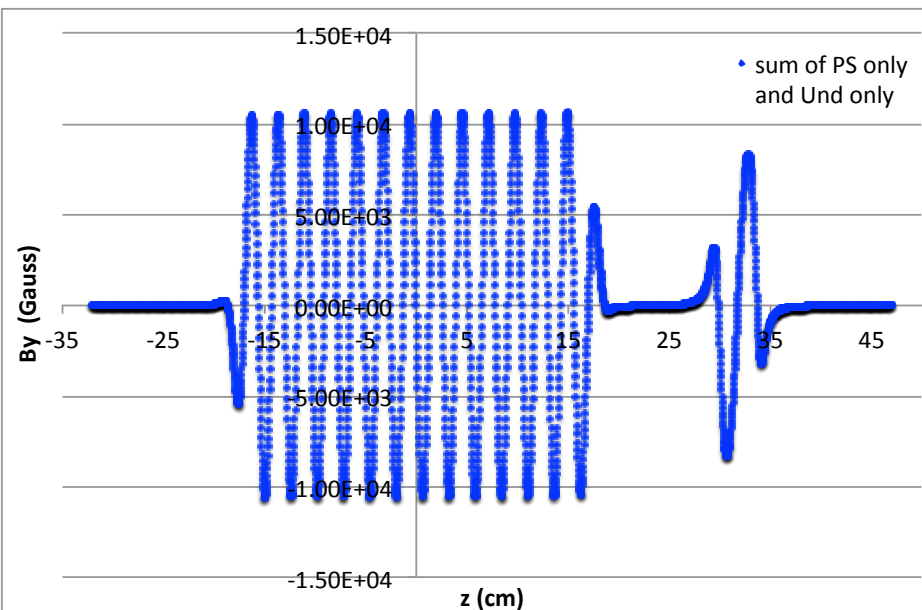

Difference (combined model - sum of individual models)

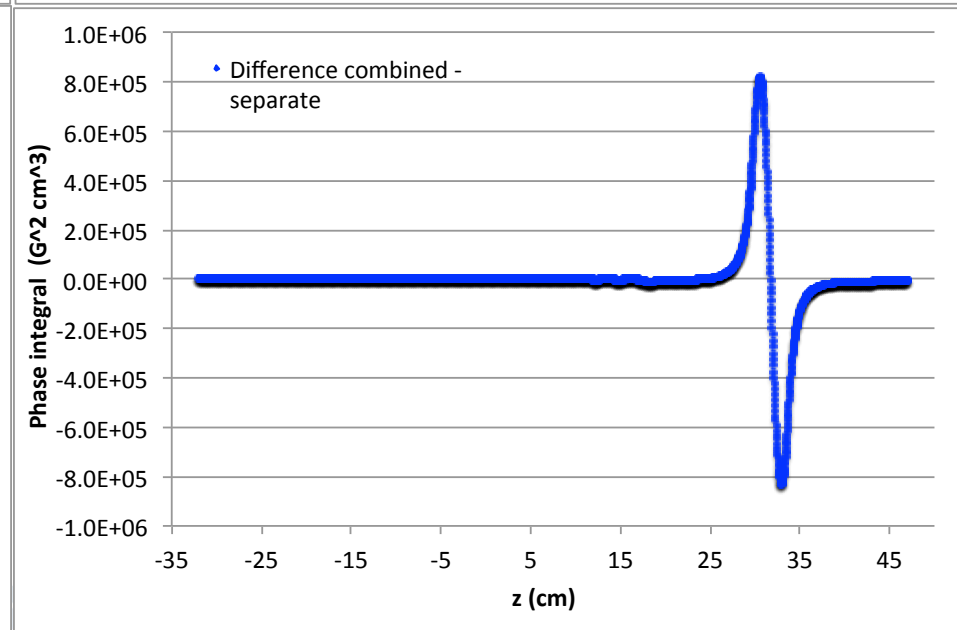
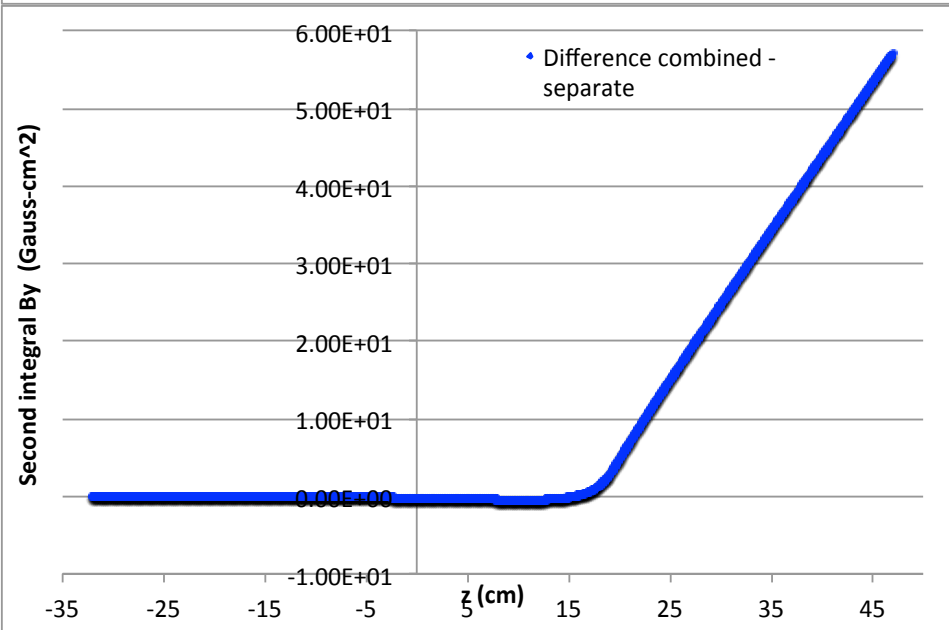
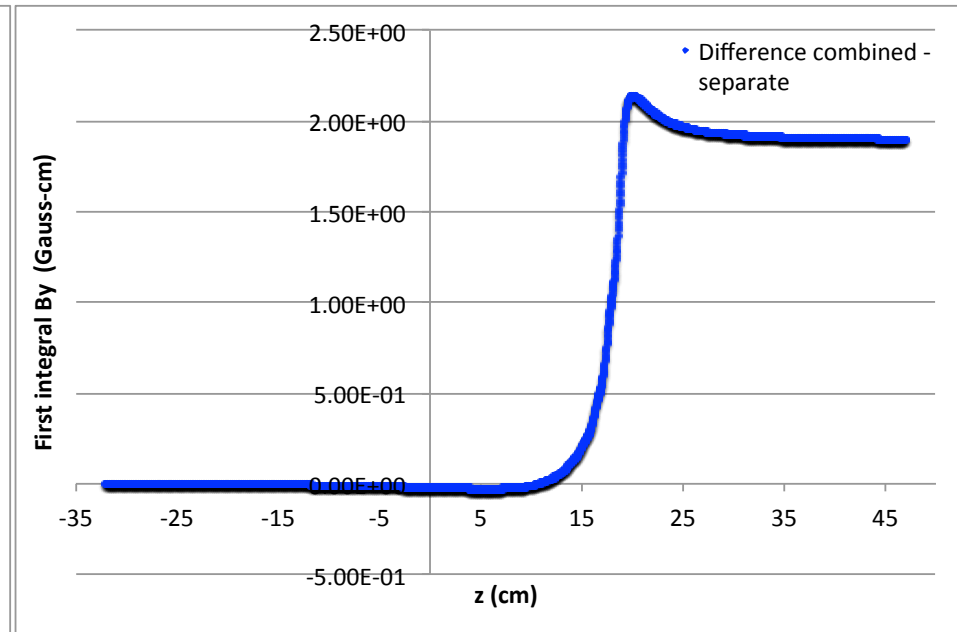
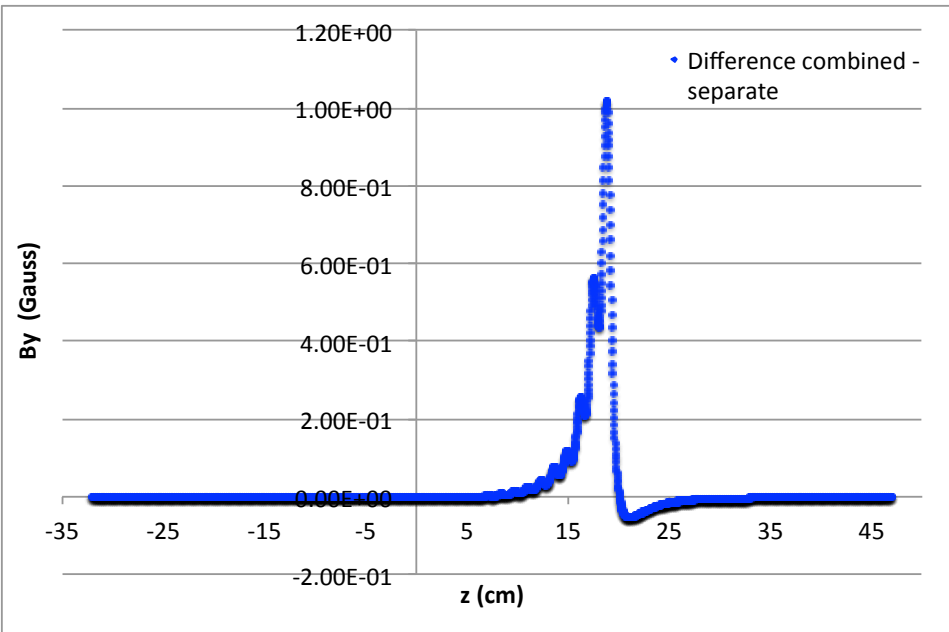

By in space between undulator and phase shifter

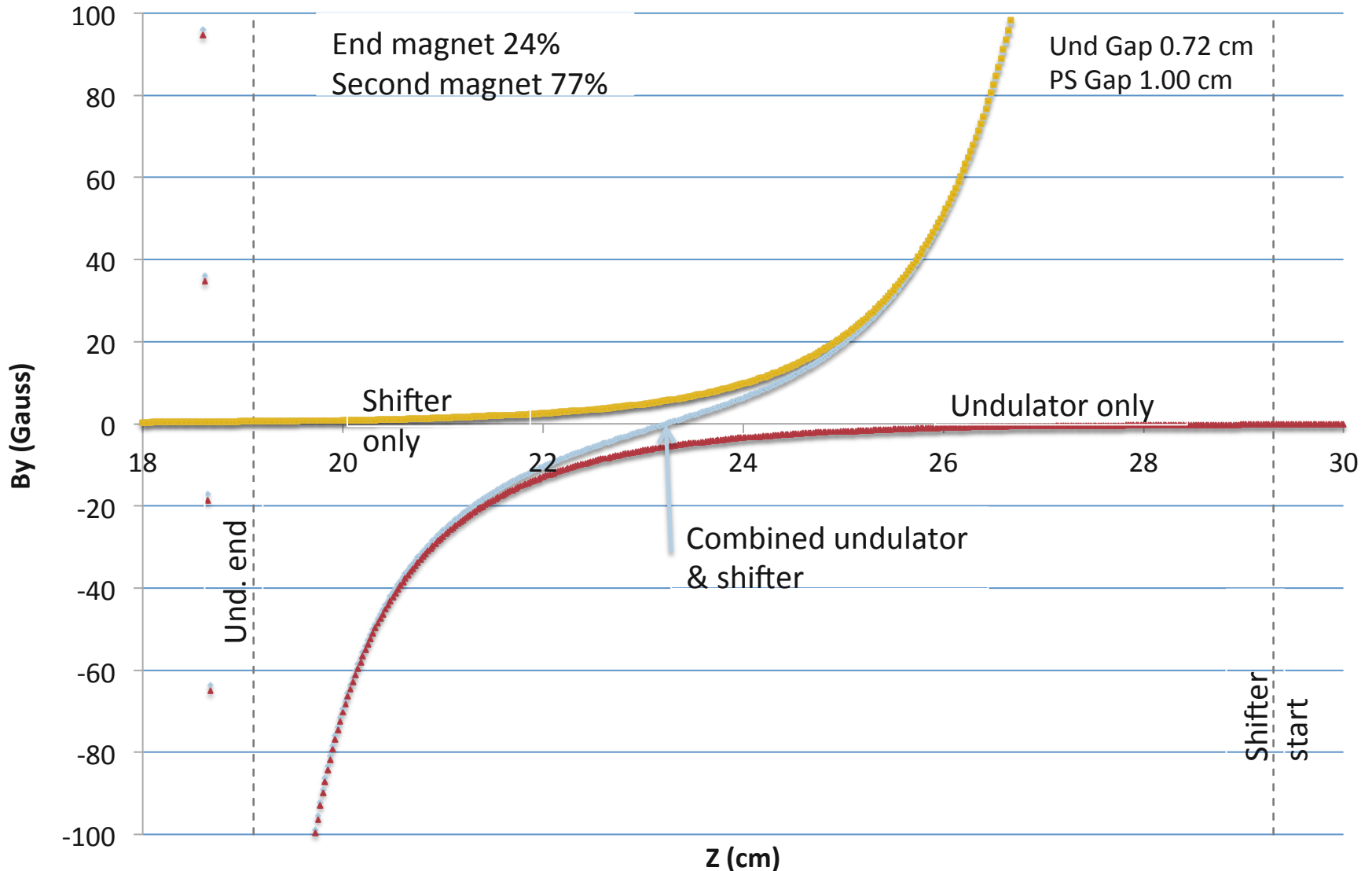

At 23.2 cm, the magnitudes of the shifter field and of the undulator field cross at 5.6 G. That's 4.12 cm from the undulator and 6.08 cm from the shifter.

Summary table

Quantity	Value	Units	Allowed for PS
Distance between undulator & phase shifter (shifter center is midway between undulator end and quadrupole shield)	10.1925	cm	
Undulator gap (minimum gap)	0.72	cm	
Phase shifter gap (minimum gap)	1.00	cm	
Interaction between undulator & shifter results in:			
Max change in B_y (occurs just before end of last und pole)	1.02	Gauss	
Change in first integral of B_y at exit of shifter	1.91	G-cm	± 20
Change in second integral of B_y at exit of phase shifter	33	G-cm ²	± 5000
Variation in phase integral internal to the phase shifter	$\pm 8 \times 10^5$	G ² cm ³	
Change in phase integral at exit of phase shifter	-3×10^5	G ² cm ³	
Phase integral through undulator (30 poles long)	3.38×10^8	G ² cm ³	
Phase integral through phase shifter	0.75×10^8	G ² cm ³	

The interaction between the undulator and shifter at minimum gap affects fields by << phase shifter allowance.

Adding shields at the ends of the phase shifter

- At the undulator-to-shifter spacing presently planned, shields are not needed.
- However, that spacing may change depending on other space demands. Besides, there was a request to investigate placing shields at the ends of the shifter when the distance to the next component is 3 cm, so the shield is centered 1.5 cm from the end of the phase shifter.
- Shield thicknesses of both 5 mm and 2 mm were calculated. The shield is assumed to be of 1010 steel.

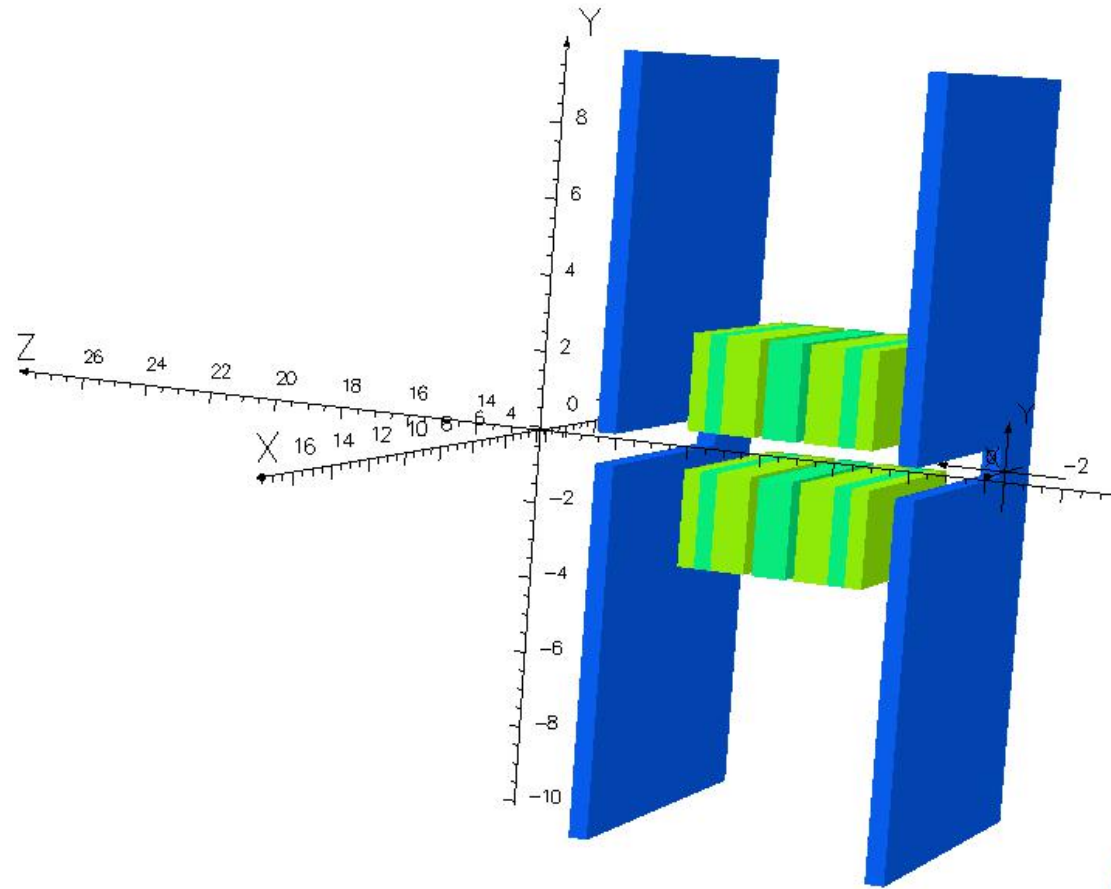

Vacuum chamber cross-section & fitting the shield

- Red dashed line outlines the slot cut into the shield.
- Outside height of vac chamber is 6 mm at the beam. (The flange shown is at the vc ends and irrelevant for the undulator.)
- Slot in shield is chosen to allow 1 mm space on both top and bottom, so it is 8 mm high. Also 1 mm allowance on left.
- Shield ends 1 mm before vac chamber widens on right (at 51mm from nominal beam), so shield half-width is 50mm.

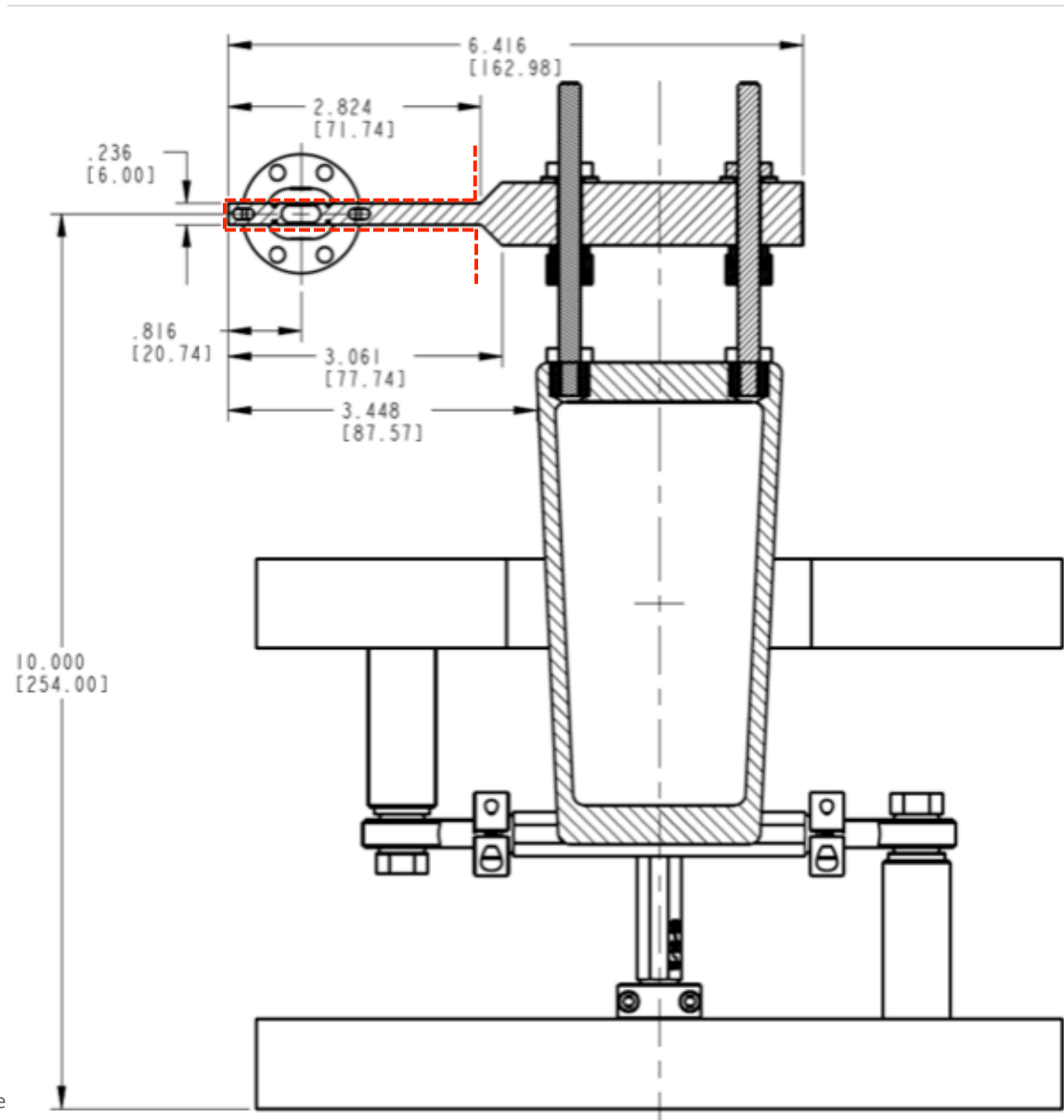

Additional shield dimensions

- With a shield half-width of 50mm and the width of the phase shifter magnets of 65 mm, the shield extends 17.5 mm beyond the shifter magnets on each side.
- A similar overhang was chosen on the top. Max phase shifter gap is 100 mm, so the top of the upper magnets is at 50 mm (the half gap) + 25 mm (height of magnets) = 75 mm. The chosen half-height of the shield, 100 mm, gives a 25-mm overhang.
- Note that, due to the slot, the shield is not left-right symmetric. This will lead to an asymmetry in the field that will need to be examined.

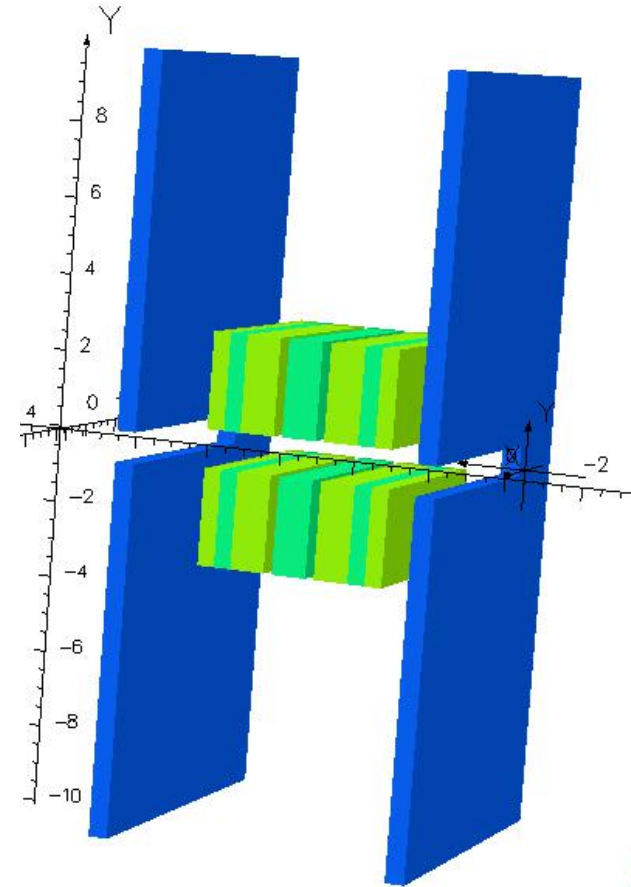

Change in B_y vs z due to shield

On-axis field both with and without the shield.

Green line shows the difference, i.e., what is removed by the shield.

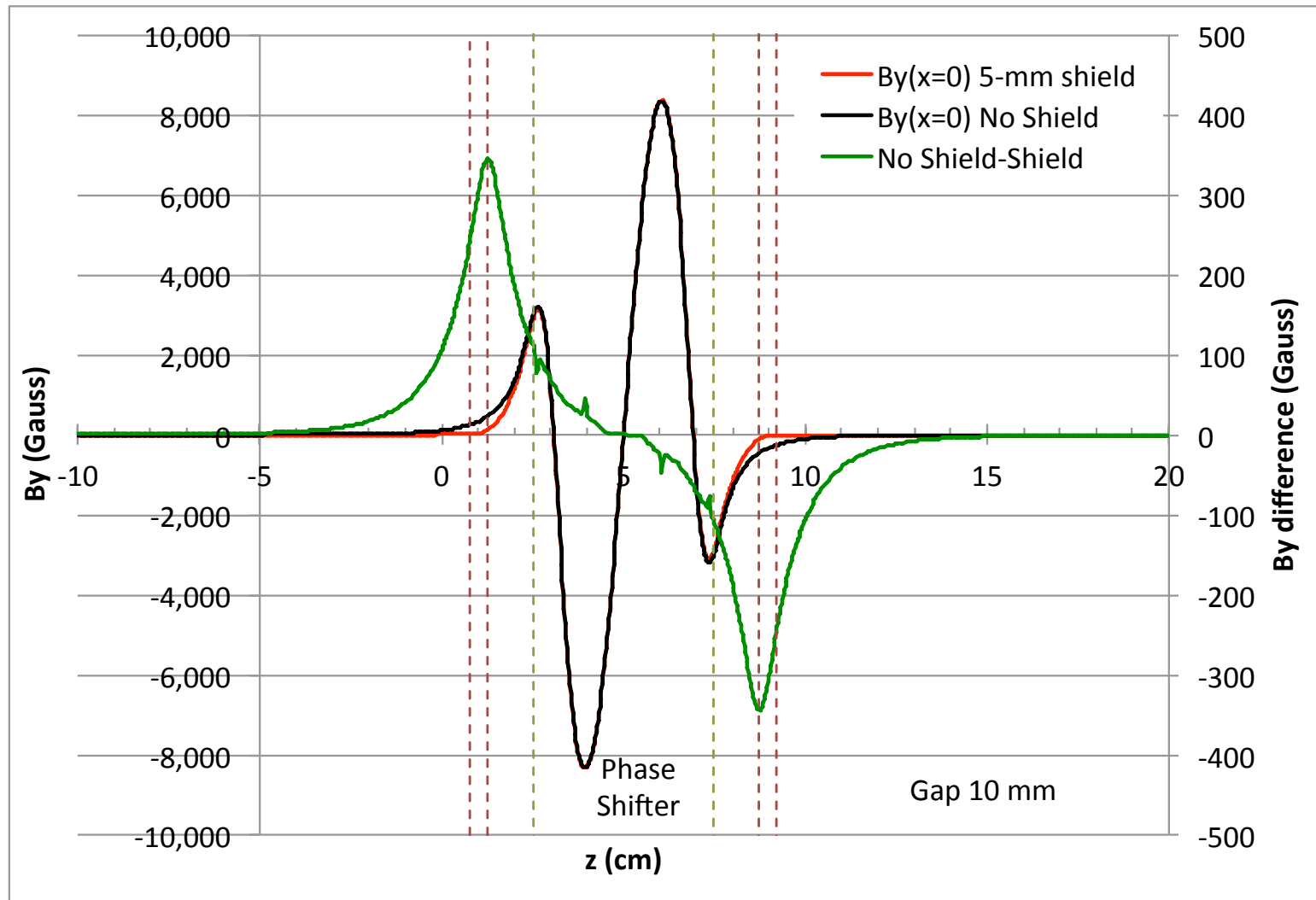

Asymmetry from 5-mm-thick shield

Shield is 5 mm thick.
Gap is 10 mm

B_y is black line.

Difference between B_y on axis and at ± 5 mm is shown by the red & blue.

Dotted lines show shields, shifter.

Large peaks inside shifter are the usual roll-off.

Difference between $+x$ and $-x$ in the shield is due to the asymmetric slot.

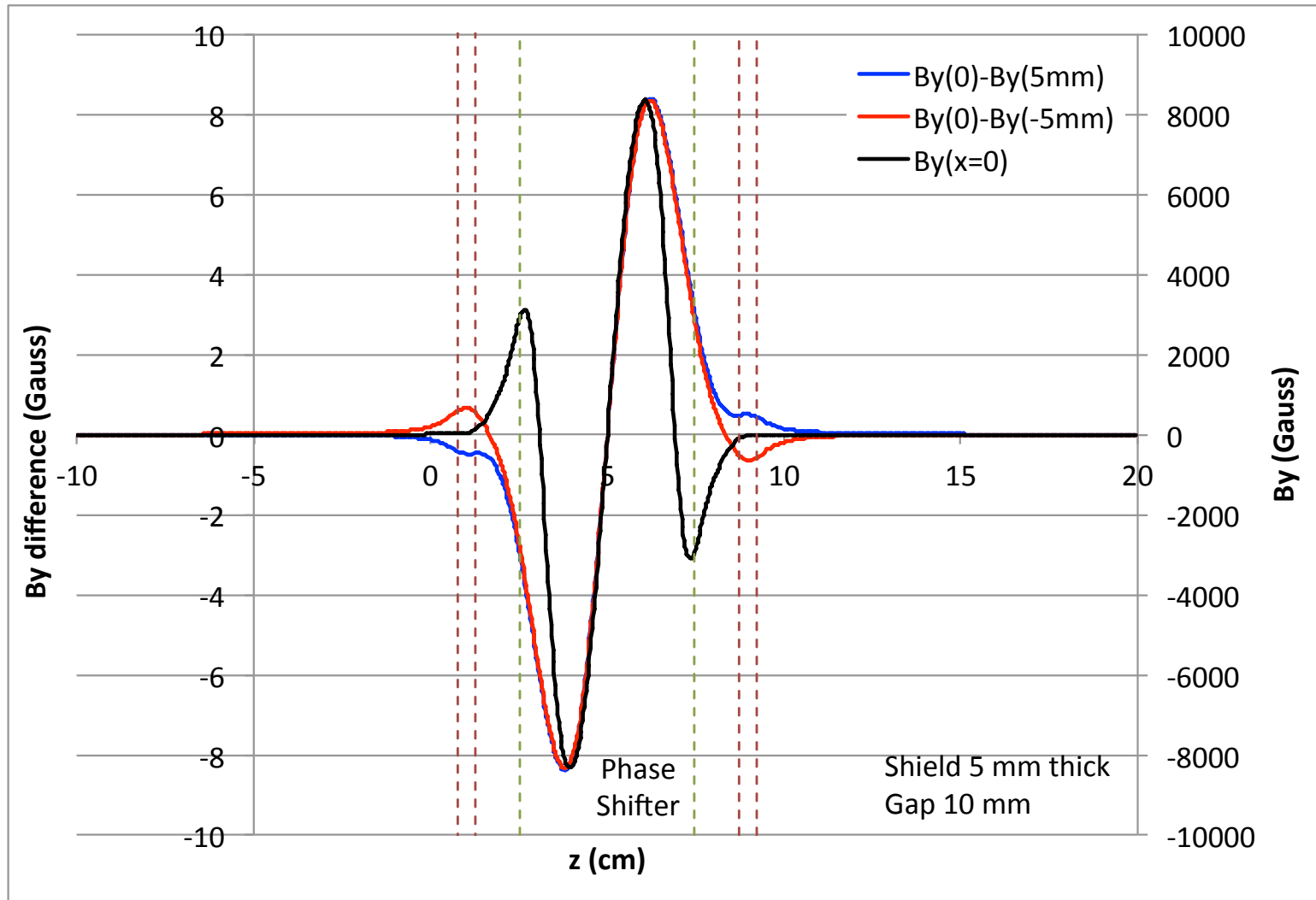

Asymmetry from 2-mm-thick shield

Shield is 2 mm thick.
Gap is 10 mm

By is black line.

Difference between B_y on axis and at ± 5 mm is shown by the red & blue.

Dotted lines show shields, shifter.

Large peaks inside shifter are the usual roll-off.

Difference between $+x$ and $-x$ in the shield is due to the asymmetric slot.

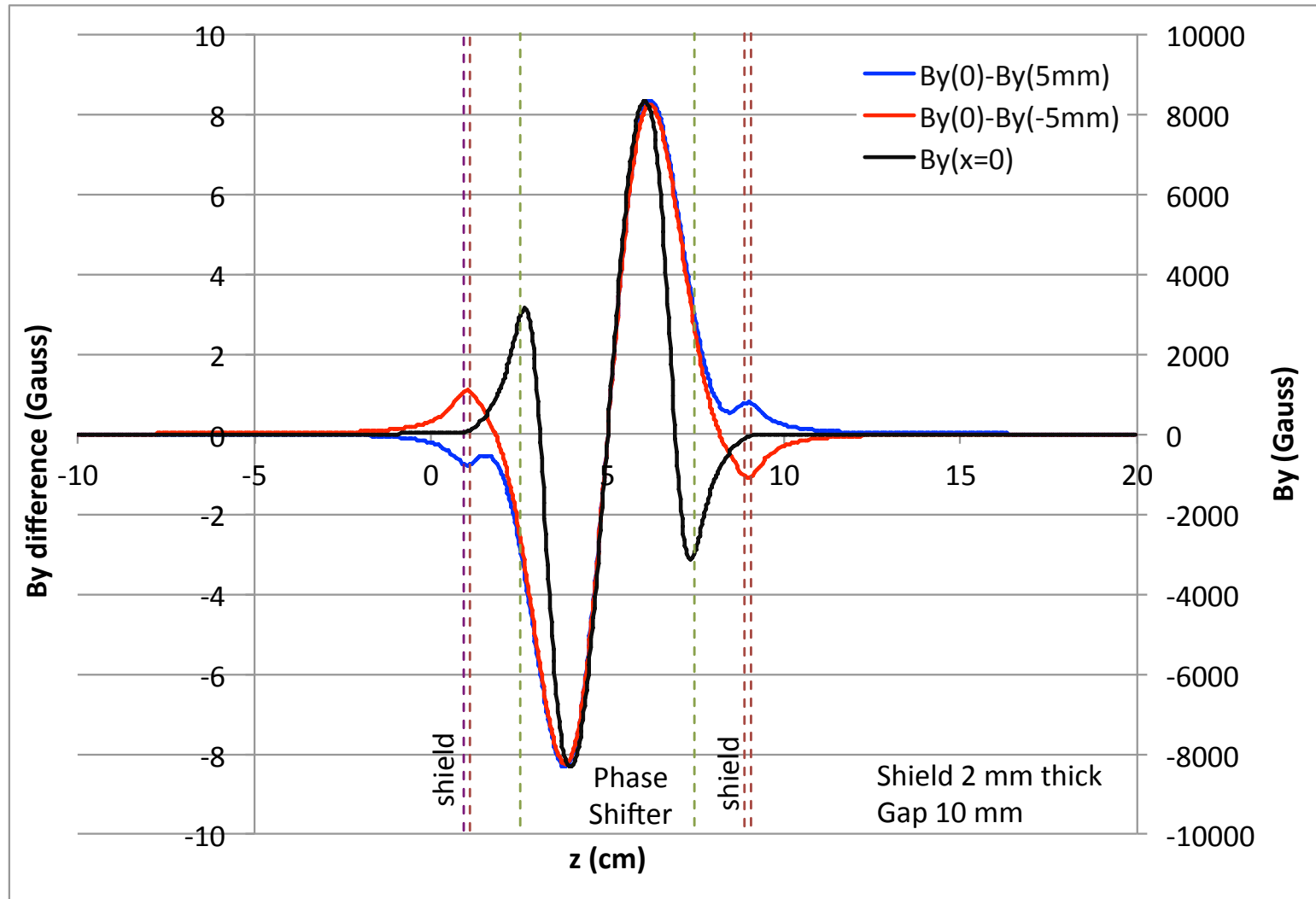

Asymmetry at open gap

Shield is 5 mm thick.

Gap is 40 mm

By is black line.

Difference between B_y on axis and at ± 5 mm is shown by the red & blue.

Dotted lines show shields, shifter.

Large peaks inside shifter are the usual roll-off.

Difference between $+x$ and $-x$ in the shield is due to the asymmetric slot.

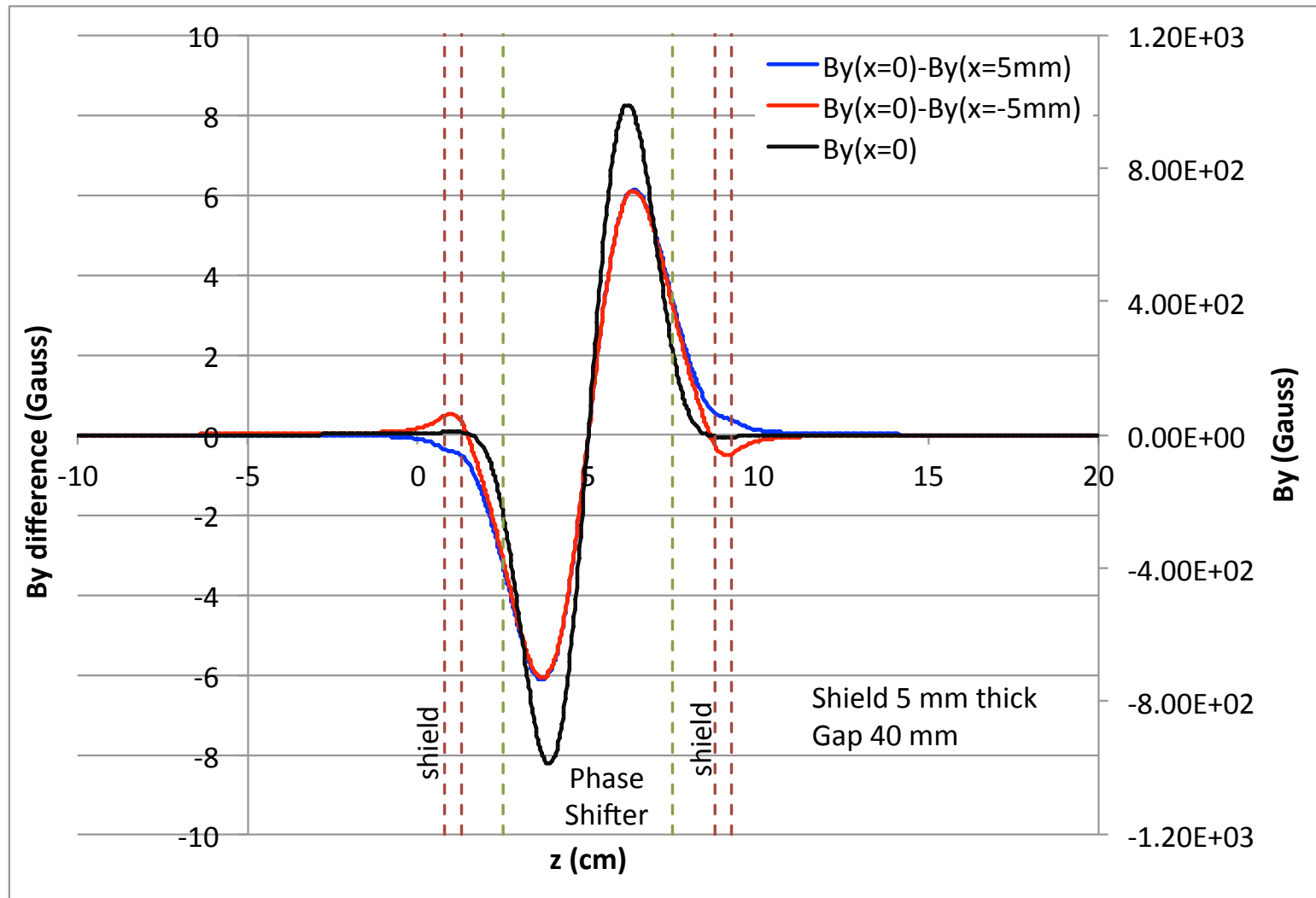

Comparison of 5-mm and 2-mm shields

Anticipate that the 5-mm shield would decrease B_y slightly more – a small effect is seen at the inside of the shield.

Difference, shown in blue, is max of ~ 90 G.

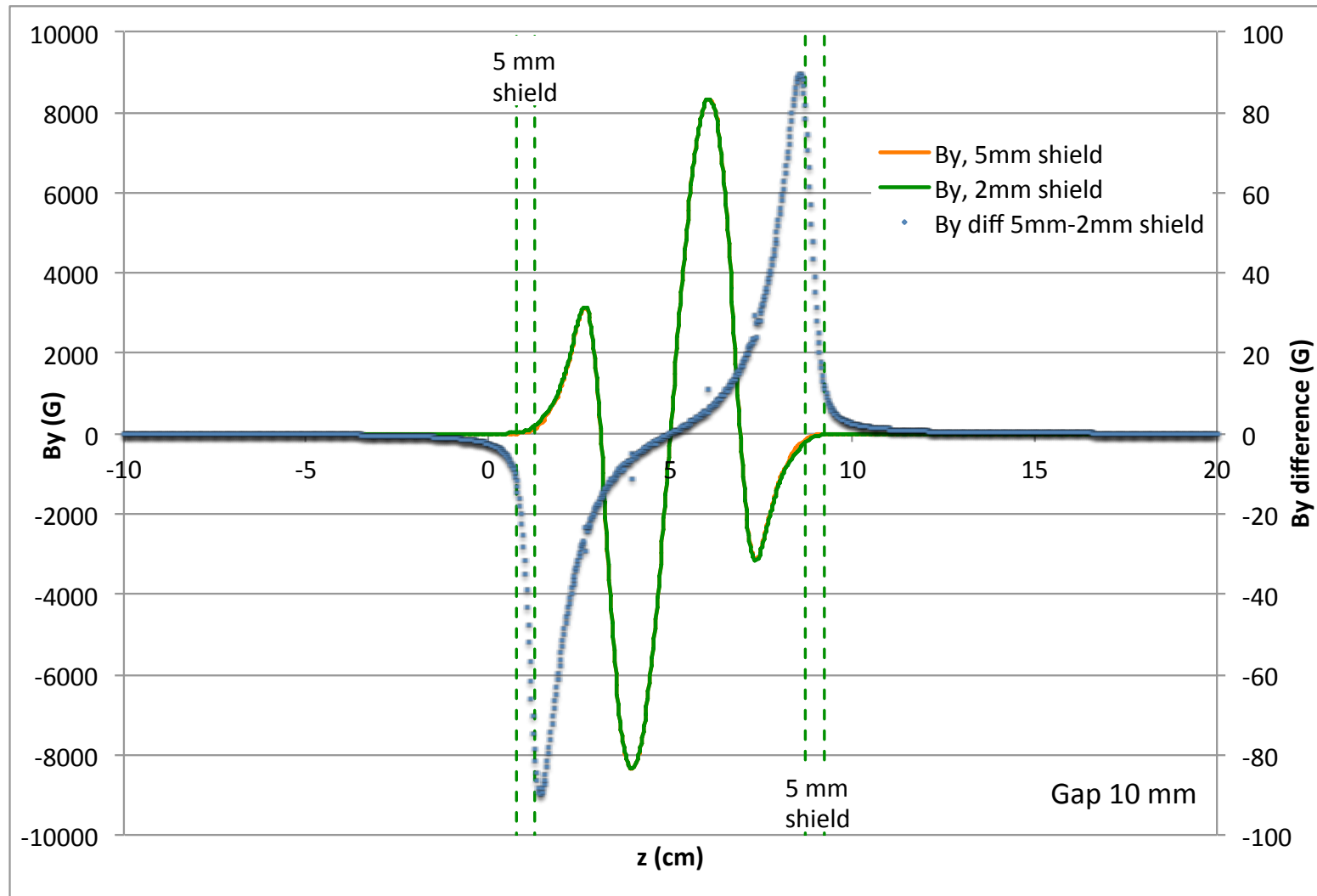

Summary

- There are now parameterized command files for use in the Vector Fields codes that can model an undulator magnetic structure of a desired length and vary the strength of the end magnets.
- There are also analysis command files to determine the trajectory through a model undulator.
- These were used to select optimal end magnet strengths.
- The undulator, with realistic ends, was then combined with a phase shifter and the crosstalk at minimum gap was examined and found to be small.
- Some characteristics of the phase shifter were examined.
- Took initial look at shields combined with the phase shifter.

Next:

- Add ability to freely vary gaps on both undulator and shifter in the combined model.
- If needed, add shields into the combined model.