

PRL-414B 1:4 FANOUT 50 Ω TTL LINE DRIVER

APPLICATIONS

- TTL/CMOS Clock Distribution
- 1:4 Fanout Line Driver
- High Speed Digital Communications System Testing
- Basic Lab Tool

FEATURES

- $f_{\max} > 100$ MHz
- Drives 100 ft of cable @ 80 MHz
- 2ns Typical Output Rise & Fall Times
- TTL Compatible 50 Ω or 1 k Ω Input
- Four in phase 50 Ω TTL Outputs
- BNC I/O Connectors
- DC Coupled I/O's
- Self-contained 1.3 x 2.9 x 2.9-in. unit includes an AC/DC Adapter

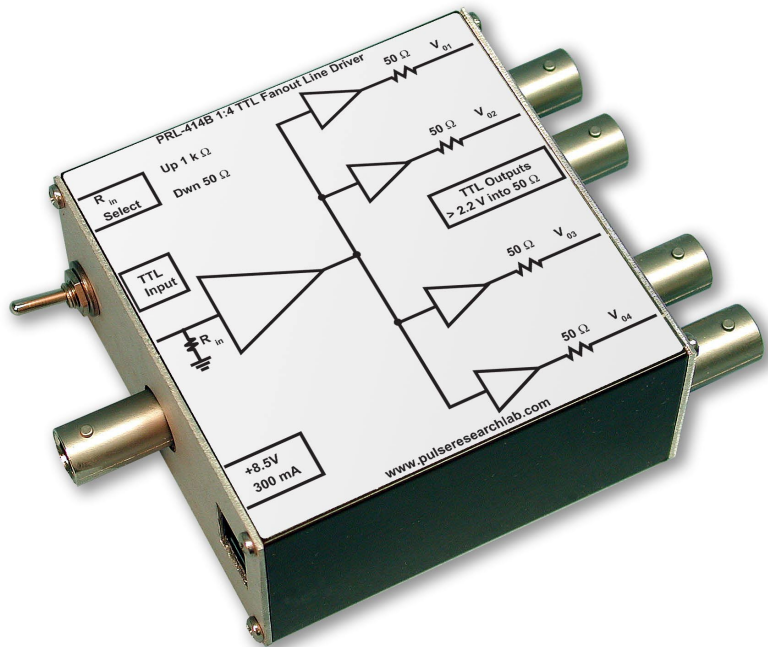

PRL-414B 1:4 TTL Fanout Line Driver

DESCRIPTION

The PRL-414B is a 1:4 fanout 50 Ω TTL Line Driver. It is intended for distribution of high-speed clock and logic signals to multiple loads via long lines. The 50 Ω back-terminated outputs can drive long lines with or without 50 Ω load terminations. With 50 Ω load terminations, however, all outputs of the PRL-414B can drive 100 ft of 50 Ω cables at clock rates greater than 80 MHz. In one important application, the PRL-414B is used for distributing a precision clock signal to a number of test stations in the lab.

The input resistance of the PRL-414B can be selected to be either 50 Ω or 1 k Ω by a switch. The 1 k Ω -input is desirable when interfacing with low power circuits. All I/O's are DC coupled and have BNC connectors.

The PRL-414B is housed in a 1.3 x 2.9 x 2.9-in. extruded aluminum enclosure and is supplied with a ± 8.5 V/ ± 1 A AC/DC Adapter. A maximum of four units can share a single AC/DC adapter using the PRL-730 or PRL-736 voltage distribution modules. If mounting is desired, a pair of the # 35001420 mounting brackets can accommodate any two PRL modules of the same length. Please refer to the Accessories Section of the literature for more detail.

A block diagram showing the equivalent input and output circuits of the PRL-414B is shown in Fig. 1.

SPECIFICATIONS* (0° C ≤ T_A ≤ 35°C)

Unless otherwise specified, dynamic measurements are made with the input set to 50Ω and all outputs terminated into 50Ω.

SYMBOL	PARAMETER	Min	Typ	Max	UNIT	Comments
R _{in Low}	Input Resistance Low Range	49.5	50	50.5	Ω	
R _{in Hi}	Input Resistance High Range	990	1000	1010	Ω	
R _{out}	Output Resistance		50		Ω	
V _{IL}	TTL input Low Level	-0.5	0	0.5	V	
V _{IH}	TTL input High Level	2.0	2.4	5.0	V	
V _{OL}	TTL Output Low Level	0	0.25	0.5	V	R _L =50 Ω
V _{OH1}	TTL Output High Level	2.2	2.5		V	R _L =50 Ω@ DC
V _{OH2}	TTL Output High Level	4.4	5		V	R _L =1 MΩ@ DC
I _{DC1}	DC Input Currents		280	350	mA	f ≤ 100 MHz
I _{DC2}	DC Input Currents		220	250	mA	f=50 MHz sq. wave ⁽¹⁾
V _{DC}	DC Input Voltages	7.75	8.5	12	V	
V _{AC}	AC/DC Adaptor Input Voltage	103	115	127	V	
T _{PLH}	Propagation Delay to output ↑		10	12	ns	
T _{PHL}	Propagation Delay to output ↓		8	12	ns	
t _r /t _f	Rise/Fall Times (10%-90%)		2.2/1.8	3	ns	f=50 MHz sq. wave
T _{SKEW}	Skew between any 2 outputs		500	1500	ps	f=50 MHz sq. wave
F _{max1}	Max. Clock Frequency ⁽²⁾		100	120	MHz	RG58C/U Cable length =3 ft
F _{max2}	Max. Clock Frequency ⁽³⁾		80			RG58C/U Cable length =100 ft
PW _{min}	Minimum Pulse Width		4		ns	↑ Input
PW _{min}	Minimum Pulse Width		6		ns	↓ Input
	Size	1.3 x 2.9 x 2.9			in.	
	Weight	5			Oz	

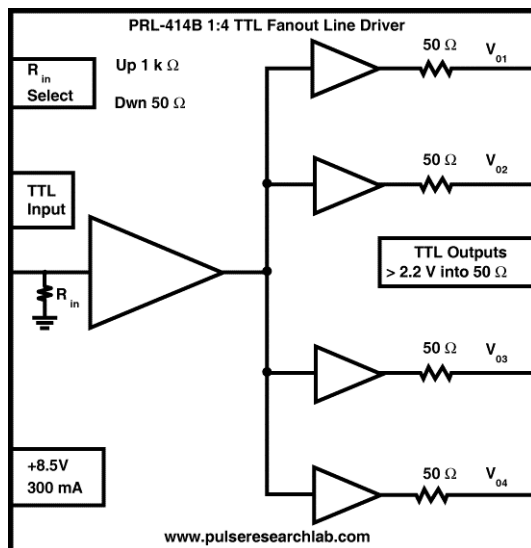

Fig. 1: PRL-414B Functional Block diagram

Notes:

- (1). For sharing a single PRL-760A, ±8.5 V, ±1.4 A AC/DC adapter, the total current should not exceed 1.4 A.
- (2). f_{MAX} should not exceed 120 MHz; otherwise, damage of the unit due to overheating may result.
- (3). f_{MAX2} is measured by connecting a second PRL-414B at the end of the 100 ft cable.