

# ***APS Operations Division Update February APS/User Meeting***

*William G. Ruzicka  
AOD Division Director  
February 25, 2004*

## ***Argonne National Laboratory***



*A U.S. Department of Energy  
Office of Science Laboratory  
Operated by The University of Chicago*



# ***APS Users Monthly Meeting Agenda February 25, 2004***

---

- **2:30 – Coffee & Cookies**
- **2:45 – Introduction. . . . . Bill Ruzicka**
- **2:50 – Update on Beamline Control  
and Data Acquisition Issues. . . . . John Maclean**
- **3:00 – Update on IT Issues. . . . . Ken Sidorowicz**
- **3:15 – Update on Operational Issues . . . . . Roger Klaffky**
- **3:30 – IXS – CDT Update and Science  
From Out of this World . . . . . Ercan Alp**
- **3:45 - Adjourn**

# ***2004 Strategic Planning Meeting***

---

- **Will hold on Aug. 29–Sept. 3, 2004 at Lake Geneva, Wisconsin with ~200 participants**
- **Will focus entirely on “New Scientific Directions for the APS”**
  - Study by Gopal Shenoy and Sunil Sinha will include workshops
- **3 days of parallel workshops, 2-day summary discussion**
- **Aimed at fleshing out Phases I and II of the strategic plan**



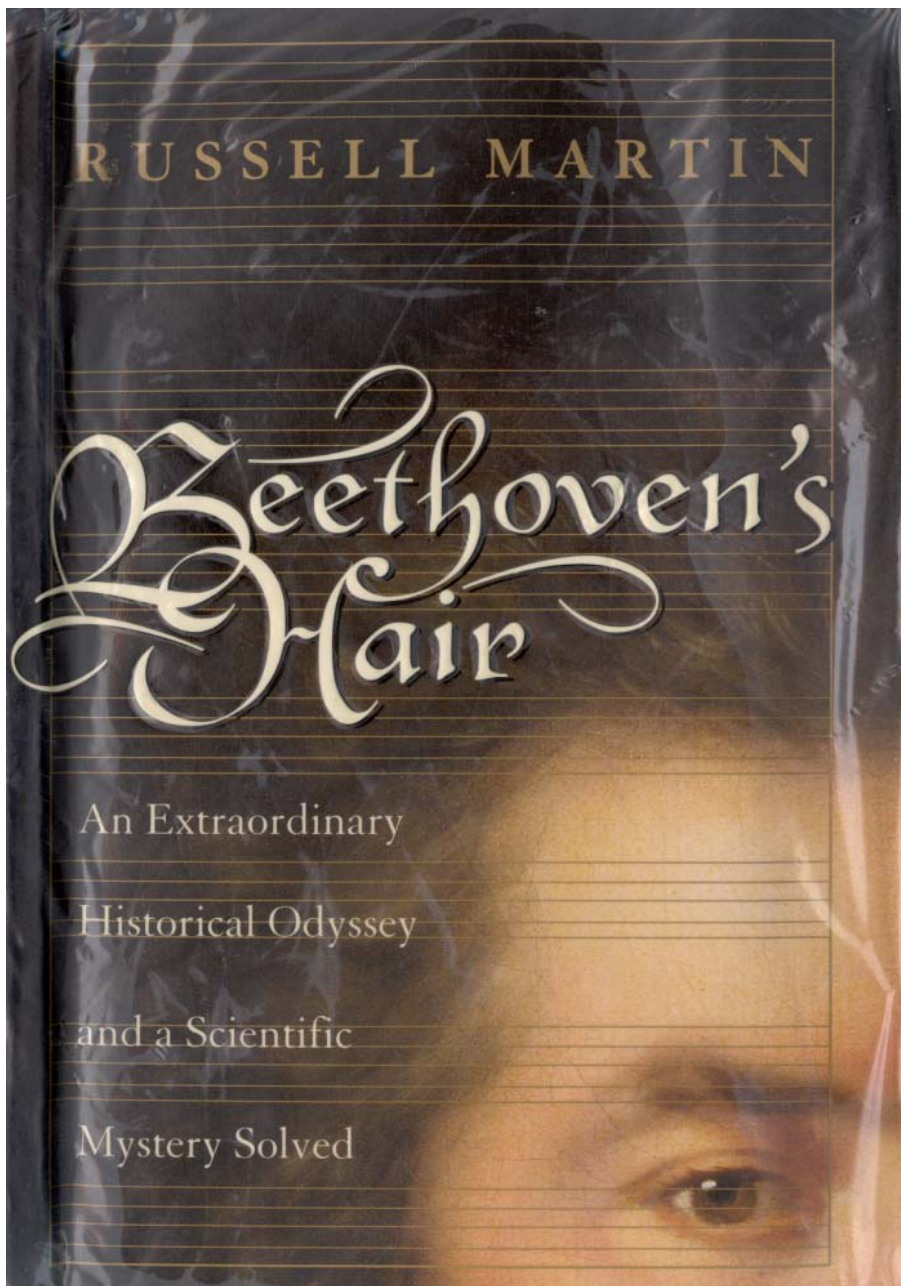

U.S. \$24.95 / Canada \$37.95

AN ASTONISHING TALE OF ONE LOCK OF  
HAIR AND ITS AMAZING TRAVELS — FROM  
NINETEENTH-CENTURY VIENNA TO TWENTY-  
FIRST-CENTURY AMERICA.

As Ludwig van Beethoven lay dying in 1827, a young musician named Ferdinand Hiller came to pay his respects to the great composer. In those days, it was customary to snip a lock of hair as a keepsake, and this Hiller did a day after Beethoven's death. By the time he was buried, Beethoven's head had been nearly shorn by the many people who similarly had wanted a lasting memento of the great man. Such was his powerful effect on all those who had heard his music.

For a century, the lock of hair was a treasured Hiller family relic, and perhaps was destined to end up sequestered in a bank vault, until it somehow found its way to the town of Gilleleje, in Nazi-occupied Denmark, during the darkest days of the Second World War. There, it was given to a local doctor, Kay Fremming, who was deeply involved in the effort to help save hundreds of hunted and frightened Jews. Who gave him the hair, and why? And what was the fate of those refugees, holed up in the attic of Gilleleje's church?

After Fremming's death, his daughter assumed ownership of the lock, and eventually consigned it for sale at Sotheby's, where two American Beethoven enthusiasts, Ira Brilliant and Che Guevara, purchased it in 1994. Subsequently, they and others instituted a series of complex forensic tests in the hope of finding the probable causes of the composer's chronically bad health, his deafness, and the final demise that Ferdinand

*(continued on back flap)*



W I D E S C R E E N

SAMUEL L. JACKSON

GRETA SCACCHI

JASON FLEMYNG

DON MCKELLAR

# THE RED VIOLIN

Directed by François Girard



"I Loved This Movie!"

-Roger Ebert, Siskel & Ebert



© 1998 Red Violin Productions Limited, Sidscar Films and TV Srl/Mikado Film Srl. All Rights Reserved.



REMI



3 1322 00348 4236

348 4234

0 "2519-20676-2" 4

"MESMERIZING!"

- NBC-TV

An epic adventure of mystery and obsession unfolds when Charles Morritz (Samuel L. Jackson), an appraiser of rare musical instruments, discovers a one-of-a-kind, blood-red violin at a prestigious Montreal auction house. Convinced he's found an authentic long-lost

### SPECIAL FEATURES

- Soundtrack Presentation
- Production Notes
- Cast and Filmmakers
- Theatrical Trailer
- Both Dolby Digital and DTS Audio Tracks

masterpiece, Morritz uncovers the spectacular journey of the priceless violin, how it changed hands and the lives of all who touched it. When the violin's shocking secret is finally revealed, Morritz must wrestle with his own demons and choose between burying the truth, and risking everything.

### SPECIAL FEATURES NOT RATED

A LIONS GATE FILMS RELEASE OF A NEW LINE INTERNATIONAL CHANNEL FOUR FILMS TELEFILM CANADA  
 Presentation Of A RHOMBUS MEDIA/MIKADO Production "THE RED VIOLIN" A Film By FRANÇOIS GIRARD CARLO CECCHI IRENE GRAZIOLI  
 JEAN-LUC BIDEAU GRETA SCACCHI JASON FLEMYNG SYLVIA CHANG COLM FEORE DON MCKELLAR and SAMUEL L. JACKSON  
 Casting DEIRDRE BOWEN Director Of Photography ALAIN DOSTIE Production Designer FRANÇOIS SÉGUIN Costume Designer RENÉE APRIL  
 Editor GAËTAN HUOT Music By JOHN CORIGLIANO Solo Violin JOSHUA BELL Line Producer BARBARA SHRIER  
 Co-Producers DANIEL IRON GIANNANDREA PECORELLI Produced By NIV FICHMAN Written By DON MCKELLAR  
 with FRANÇOIS GIRARD Directed By FRANÇOIS GIRARD

© 1998 Red Violin Productions Limited, Sidscar Films and TV Srl/Mikado Film Srl. All Rights Reserved.

[www.universalstudios.com/home](http://www.universalstudios.com/home)

LANGUAGE	English	1.85:1	Dolby Digital and DTS soundtracks contain up to 5.1 channels of discrete audio. Dolby Surround soundtracks contain up to 4 channels of encoded audio. Playback from 2-channel DVD outputs is compatible with Dolby stereo and Dolby Pro Logic reproduction. DTS Digital Surround play required the use of a DTS Decoder.
		ANAMORPHIC WIDESCREEN	
CAPTIONS SUBTITLES	Captioned	COLOR	Dual Layer 2 Hours 12 Minutes 20676

TM Universal City Place, Universal City, CA 91608. © 1999 Universal Studios. All Rights Reserved. Printed in USA. WARNING: For private home use only. Downloaded audio performance. Broadcasting or copying is a violation of applicable laws. Dolby and the Double D symbol are trademarks of Dolby Laboratories Licensing Corporation.

THIS DISC IS COMPATIBLE WITH ALL DVD PLAYERS DISPLAYING THESE SYMBOLS. AUTHORIZED USE IN THE U.S. AND CANADA.



- **X-rays show heavy metal**

- Ludwig, who died at age 57 in 1827, had elevated lead levels
- (60 ppm, average American .6 ppm)
- This may confirm that his many years of chronic illness may have been due to lead poisoning.

- **XOR-2-BM Utilized**

- Derrick Mancini, CNM/XFD
- Francesco DeCarlo, XFD
- Bill Walsh, ER
- Ken Kramer, ER

---

- Murray Gibson



**Some to be actors**



# *Main Control Room and in Sector 2*

---



**Filmed May 11- 14 (shutdown)**

**Some shots in  
Sector 2 - we will  
need some people  
who look like  
scientists**





## 2005 Prediction – Best Actor in Scientific Support Role



# ***Thermal Analysis for Higher Beam Current***

- Identify critical front-end and beamline components ✓
- Establish realistic design criteria for low-cycle fatigue life
- Perform finite element thermomechanical analyses

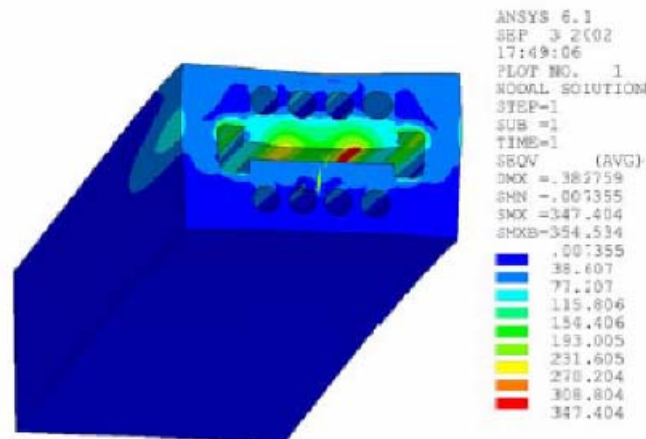

**Temperature Contours in 23-ID PS2 Photon Shutter**

## Realistic Design Criteria for Low-Cycle Fatigue Life

- The design criteria will be investigated and established by the following committee members:
  - *Professor Mike Gosz (Illinois Institute of technology)*
  - *Dr. Lin Zhang (ESRF)*
  - *Dr. Saurin Majumdar (ET, ANL)*
  - *Sushil Sharma (ASD)*
  - *Yifei Jaski (XFD)*

## Perform Finite Element Thermomechanical Analyses

- The analyses will be performed during the next few months by Yifei Jaski and a PhD student from IIT



# ***PV Naming Convention***

---

- **New APS site wide process variable (PV) naming convention.**
- **All sectors, except two, fell into new naming convention, formulated by Ned Arnold.**
- **APS had planned to “Grandfather” these non-standard CAT PV group names, but the two CATs volunteered to change their PV names.**

# PV Naming Convention

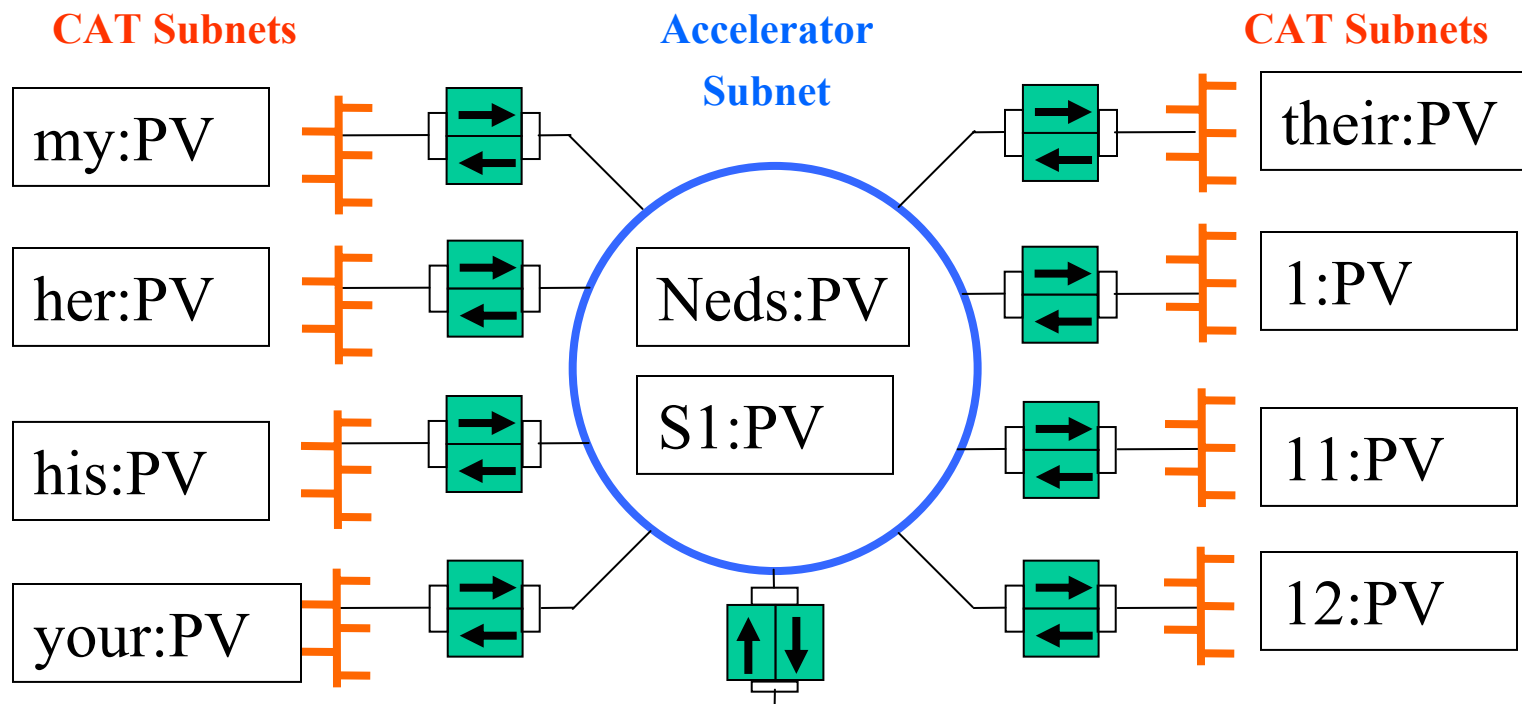

- A site wide convention helps to avoid name conflicts

# ***T-Shirt Awards***

---

**Therefore a T-Shirt Award is due.**

**Bill Lavender of IMCA & MR CAT**

**Lisa Keefe of IMCA CAT**

**Carlo Segre of MR CAT**

**Ned Arnold – Group Leader of Controls and**

**T-Shirt Award Nominator – John Maclean, Group Leader, BCDA**