

ARGONNE
NATIONAL LABORATORY



United States
Department of Energy

The University of Chicago

ENTRANCE

The LCLS Project

Stephen Milton, APS

Argonne National Laboratory



*A U.S. Department of Energy
Office of Science Laboratory
Operated by The University of Chicago*



History of X-Ray Generation

History of (8-keV) X-Ray Sources

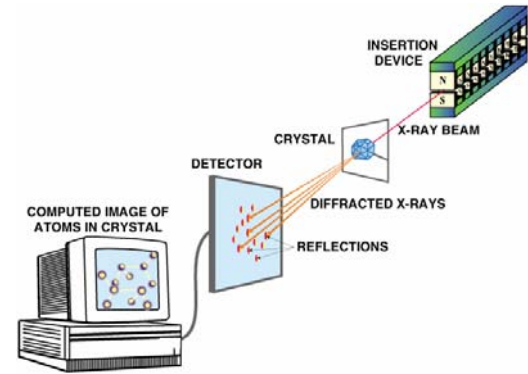
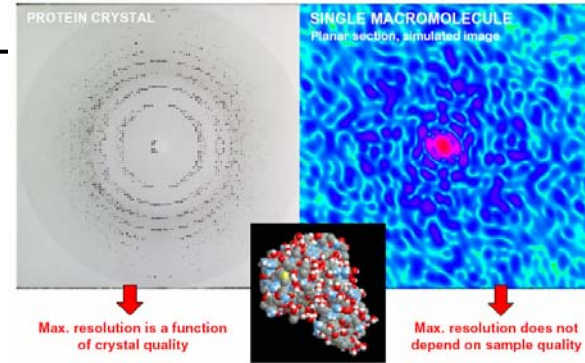
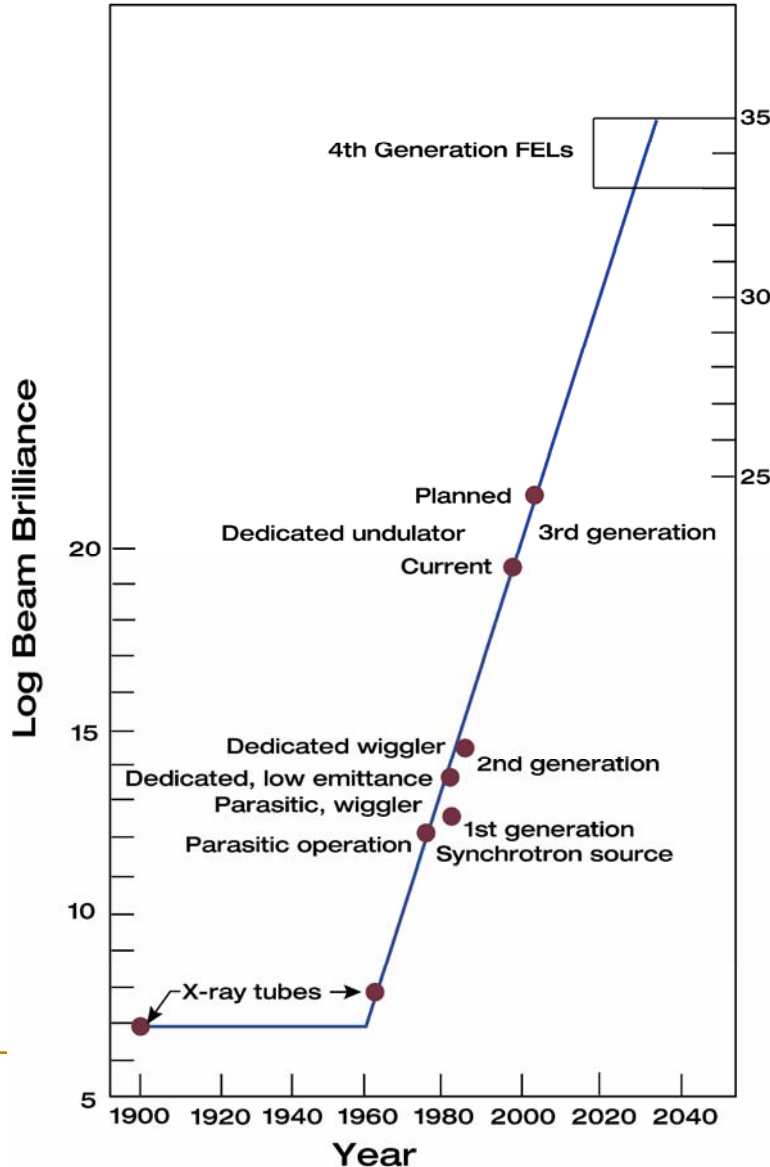

Multiple Electrons

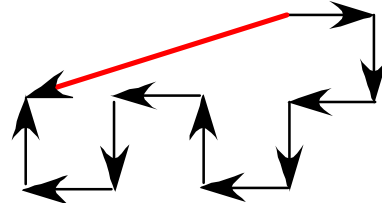
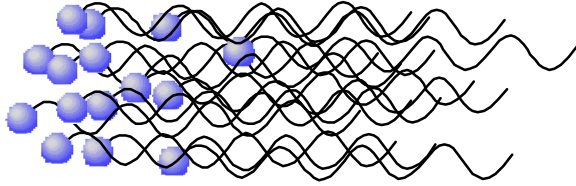

Incoherent Emission

If the electrons are independently radiating light then the phase of their electric fields are random with respect to one another and the electric field scale as the square root of the number of electrons



Coherent Emission

If the electrons are in lock step and radiate coherently then the electric field grows linearly with the number of electrons

The power goes as the square of the field and if N is very large one can get an enormous gain in power emitted.

This is the essence of the Free-electron laser.

Interaction Between the Electron and EM Field

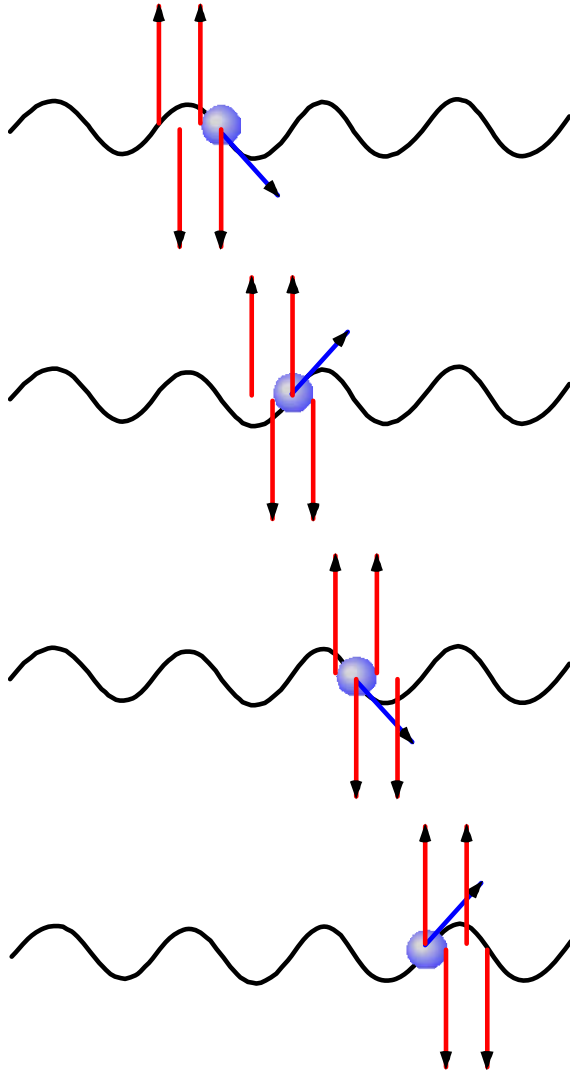

If the electron oscillates in phase with a co-propagating EM field of the correct frequency it can pick up or lose a net amount of momentum. Whether it picks up momentum or loses some is depended on the phase relationship.

In an assemble of electrons this process can create microbunching within the macroscopic electron bunch.

Simulated Microbunching in the Beam

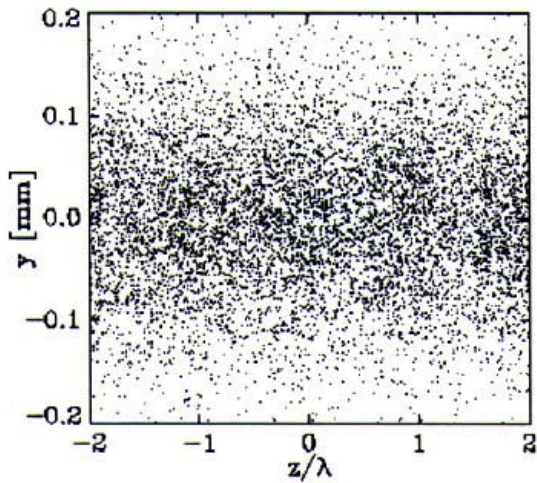

At entrance to the undulator

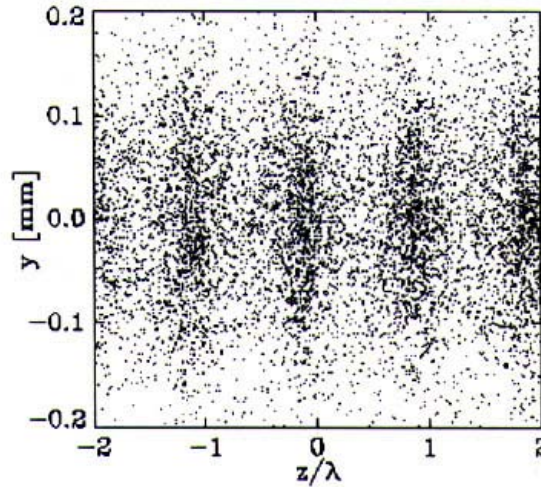

Exponential gain regime

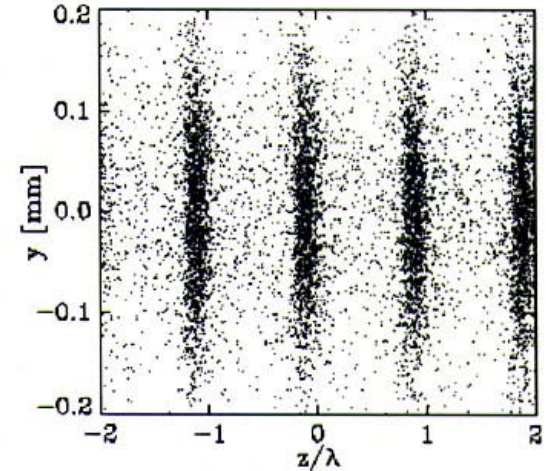

Saturation(maximum bunching)

Excerpted from the TESLA Technical Design Report, released March 2001

Self-Amplified Spontaneous Emission (SASE)

Exponential Growth

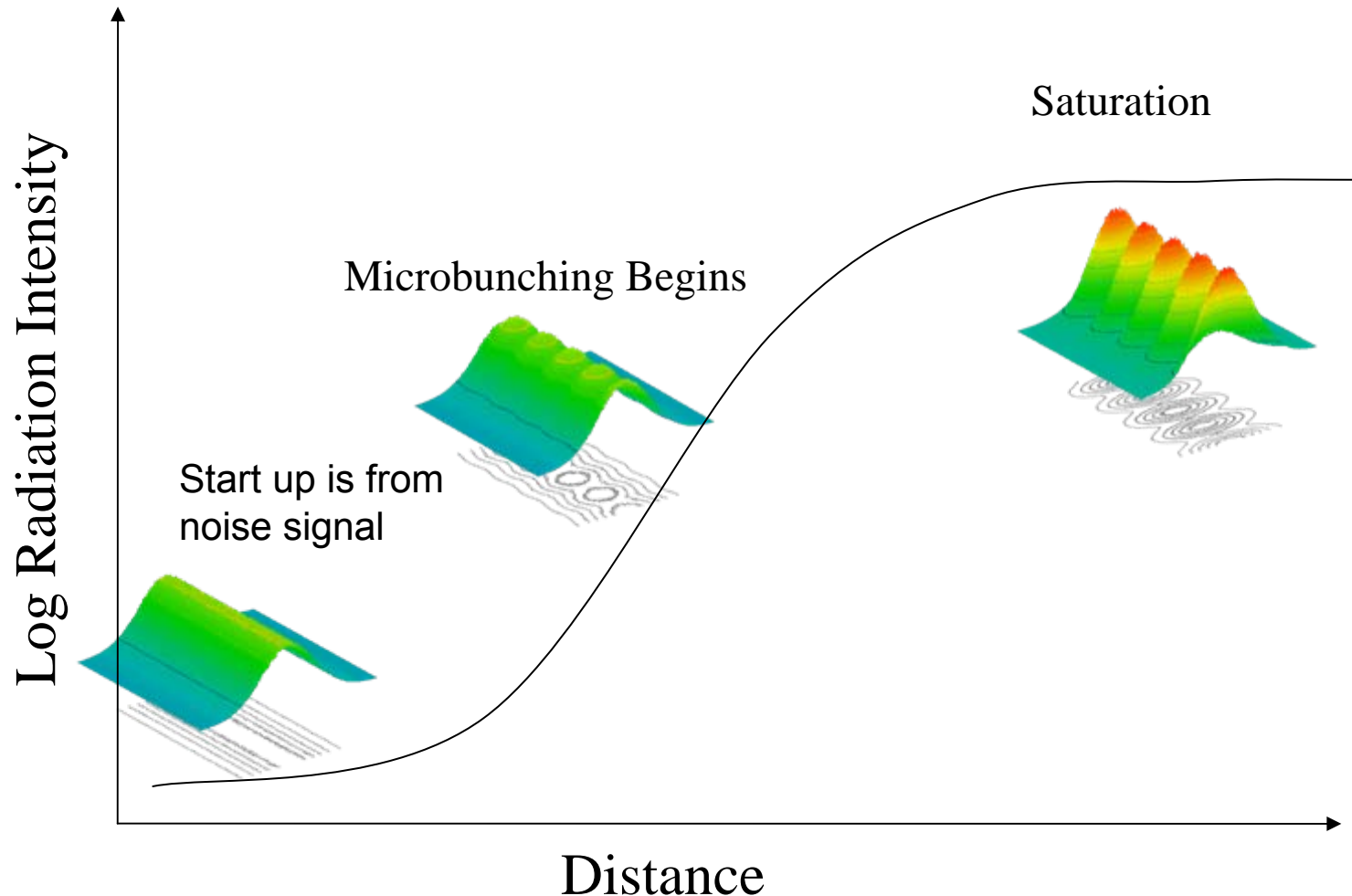

Required Conditions

$$\varepsilon_n \leq \gamma \frac{\lambda_r}{4\pi} \quad \Rightarrow \quad \text{Want the beam emittance to be less than the optical mode Phase space size.}$$

$$\frac{\Delta E}{E} \leq \rho \approx \frac{1}{4} \left[\frac{1}{2\pi^2} \frac{I_{pk}}{I_A} \frac{\lambda_u^2}{\beta \varepsilon_n} \left(\frac{K}{\gamma} \right)^2 \right]^{1/3} \quad \Rightarrow \quad \text{The Pierce parameter, } \rho, \text{ should be large and the beam energy spread should be smaller than } \rho.$$

$$L_g < L_R \quad L_R = \frac{2\pi\sigma_o^2}{\lambda_r} \quad \Rightarrow \quad \text{The optical intensity should grow fast enough to counter diffraction loss.}$$

$$L_g \approx \frac{\lambda_u}{4\pi\sqrt{3}\rho} \quad \Rightarrow \quad \text{Want a Minimum gain length so want } \rho \text{ to be as large a possible. i.e Want large } I_{pk} \text{ and a small beam emittance.}$$

First SASE FEL to Saturation

530 nm Intensity vs Distance: Sept. 23, 2000

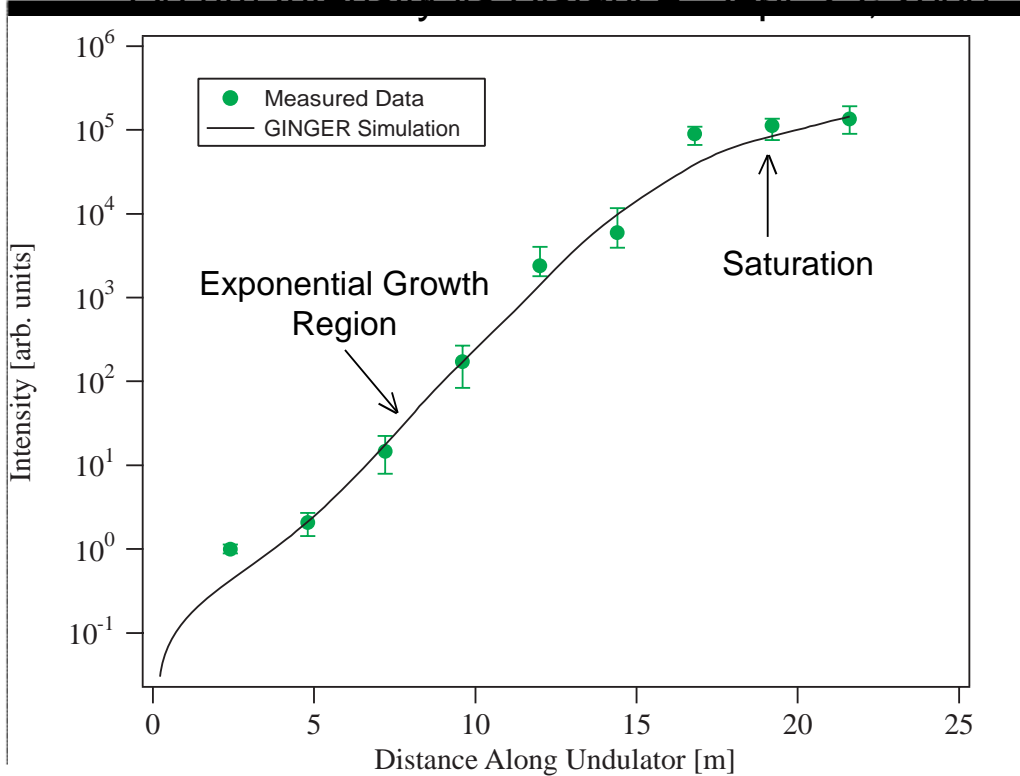

Flash of UV light (385 nm) near saturation. The expected wavelength as a function of angle (radial offset) is clearly seen. The darker “lines” are from shadows of secondary emission monitors in the vacuum chamber.



S. Milton et al., Science, Vol. 292, Issue 5524, 2037-2041 (2001)

Next Generation Capabilities

Spectral coverage: 0.15-1.5 nm

To 0.5 Å in 3rd harmonic

Peak Brightness: 10^{33}

Photons/pulse: 10^{12}

Average Brightness: 3×10^{22}

Pulse duration: <230 fsec

Pulse repetition rate: 120 Hz

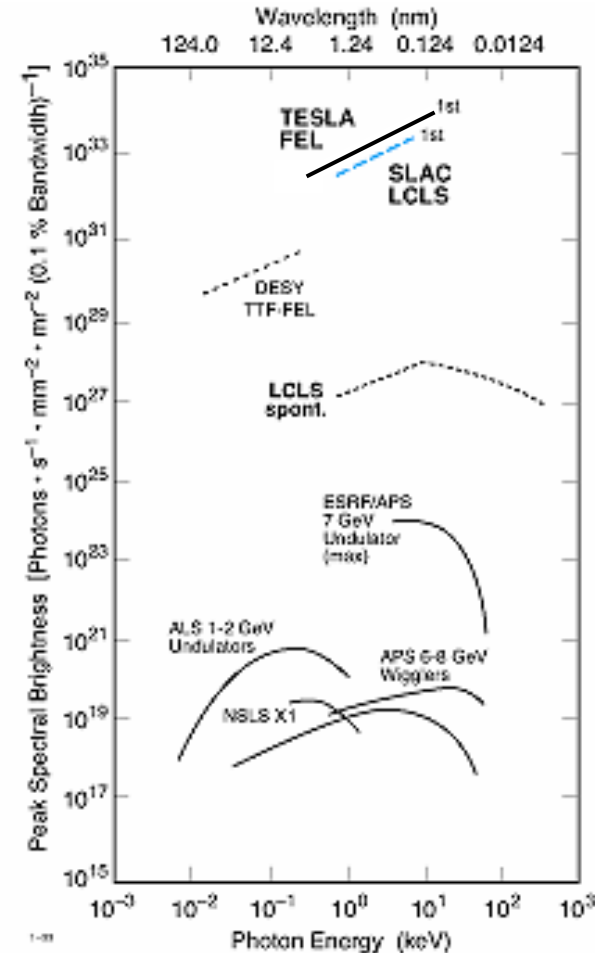
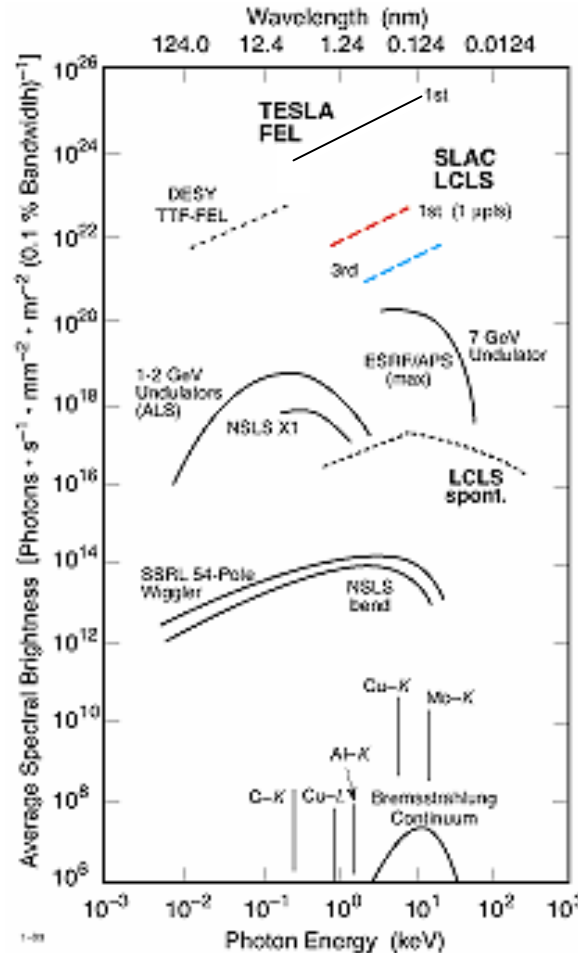

The World's First X-Ray Free-Electron Laser

Ultra-Small

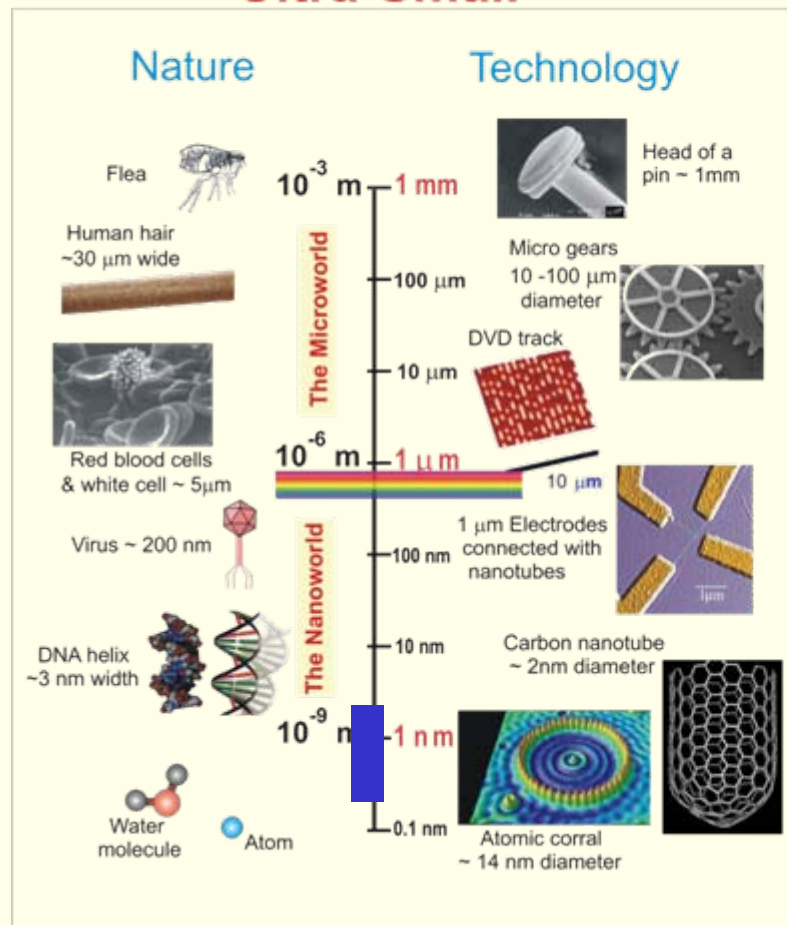

Ultra-Fast

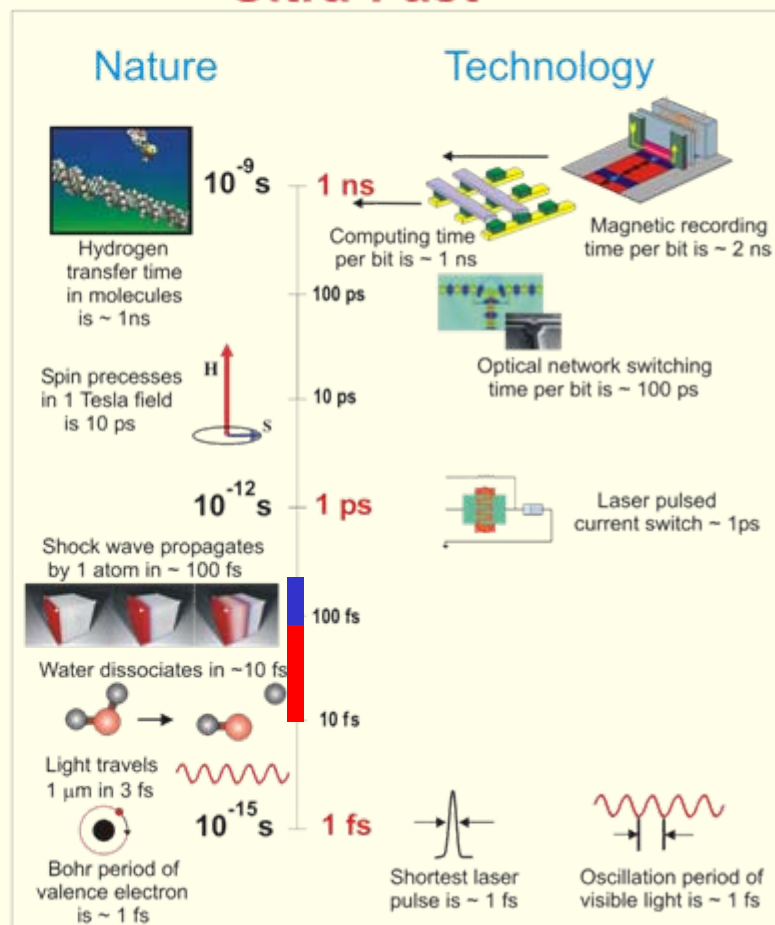

Strong Scientific Case

- Presented to BESAC 10-Oct-2000
- Critical Decision 0 approved 13-June 2001

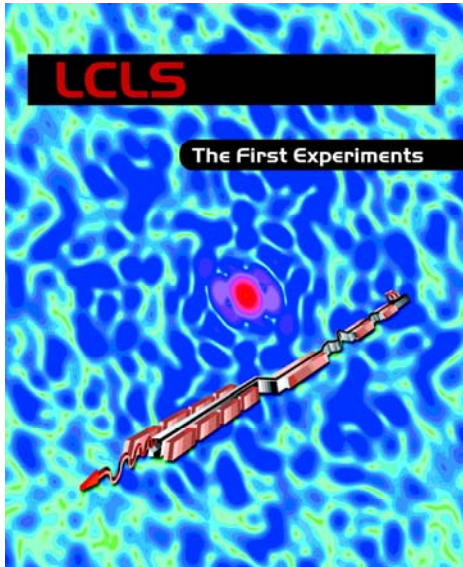

Program developed by international team of scientists working with accelerator and laser physics communities

“the beginning.... not the end”

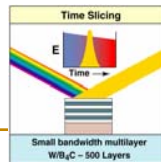
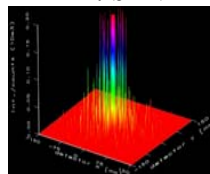
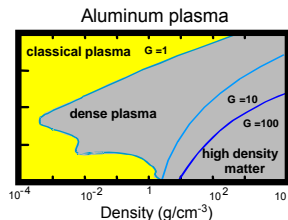
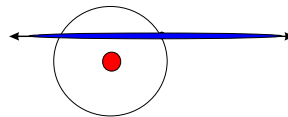
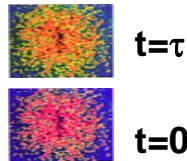
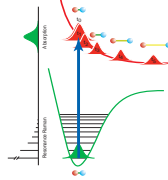

Femtochemistry

Nanoscale Dynamics in Condensed matter

Atomic Physics

Plasma and Warm Dense Matter

Structural Studies on Single Particles and Biomolecules

FEL Science/Technology

LCLS Project Overview

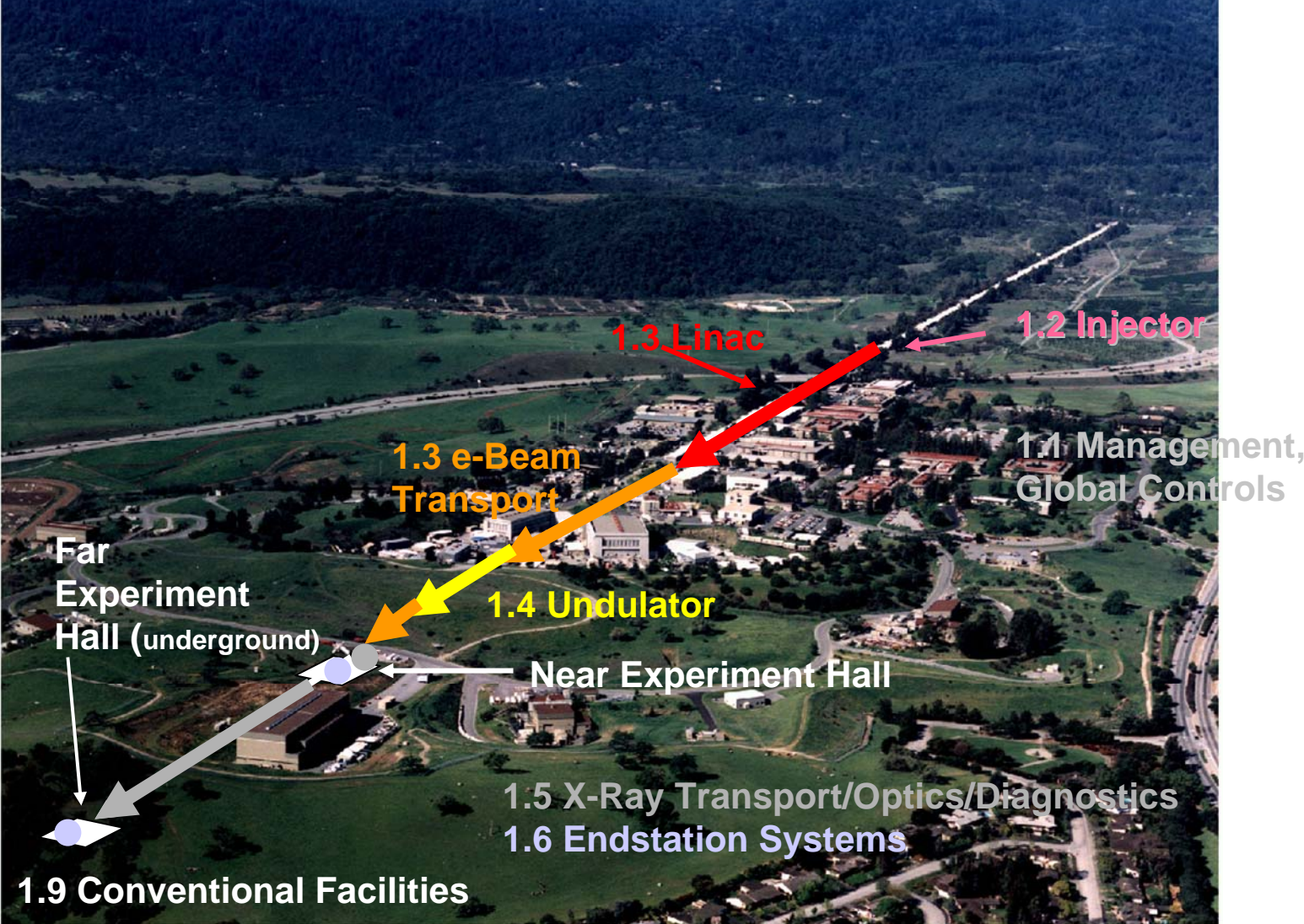

1.9 Conventional Facilities

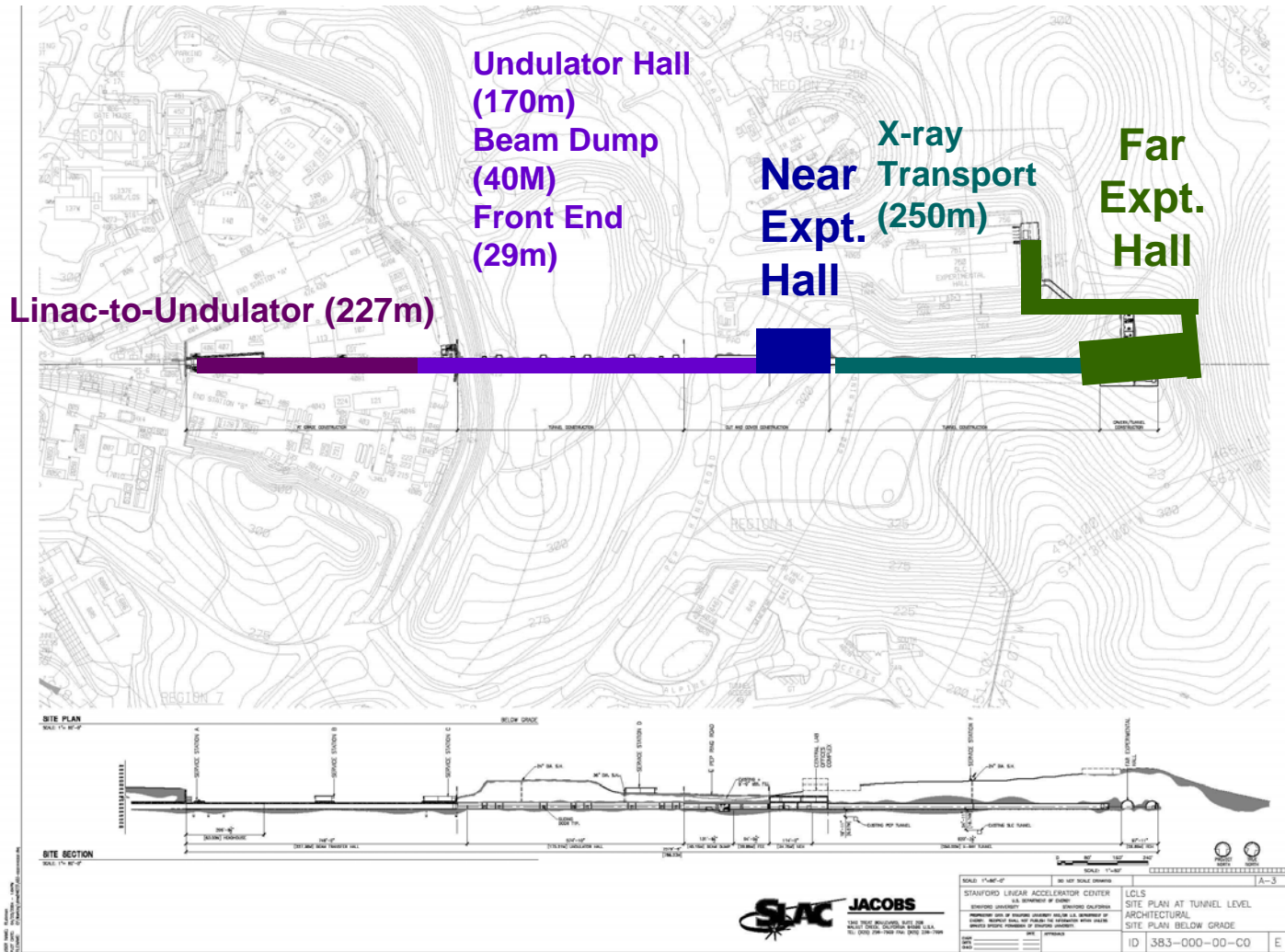

New FEH design

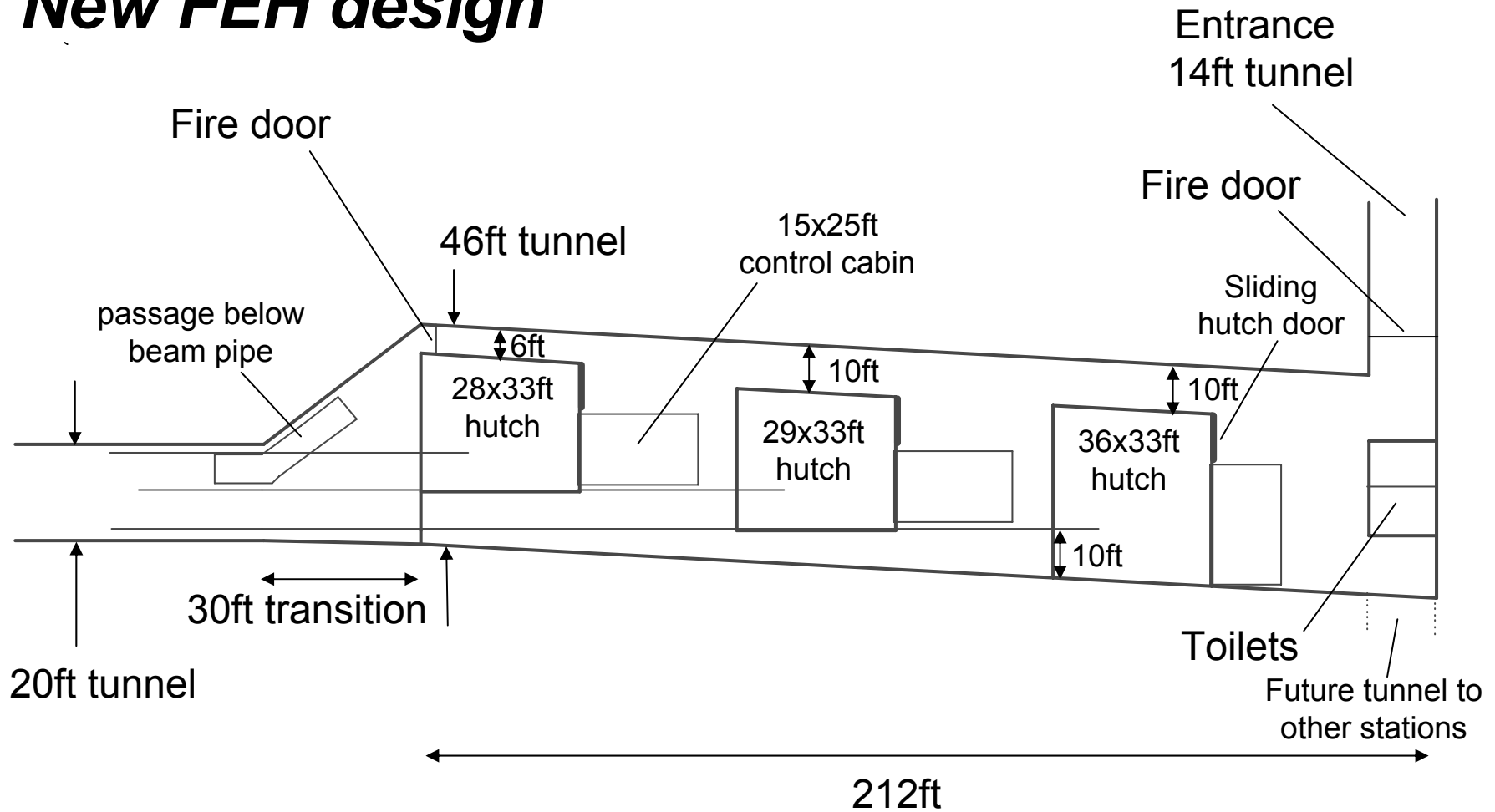

Project Cost and Schedule

- **\$315M Total Estimated Cost range**
- **\$387M Total Project Cost range**
 - **FY2005** Long-lead purchases for injector, undulator
 - **FY2006** Construction begins
 - **January 2008** FEL Commissioning begins
 - **September 2008** Construction complete

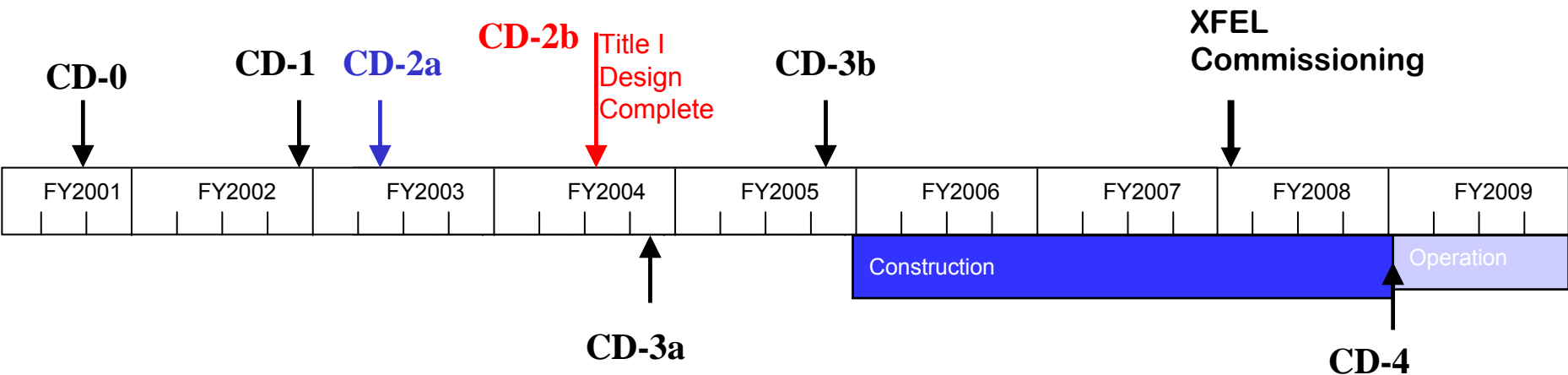

LCLS Project: ANL Component

The LCLS (Linac Coherent Light Source)

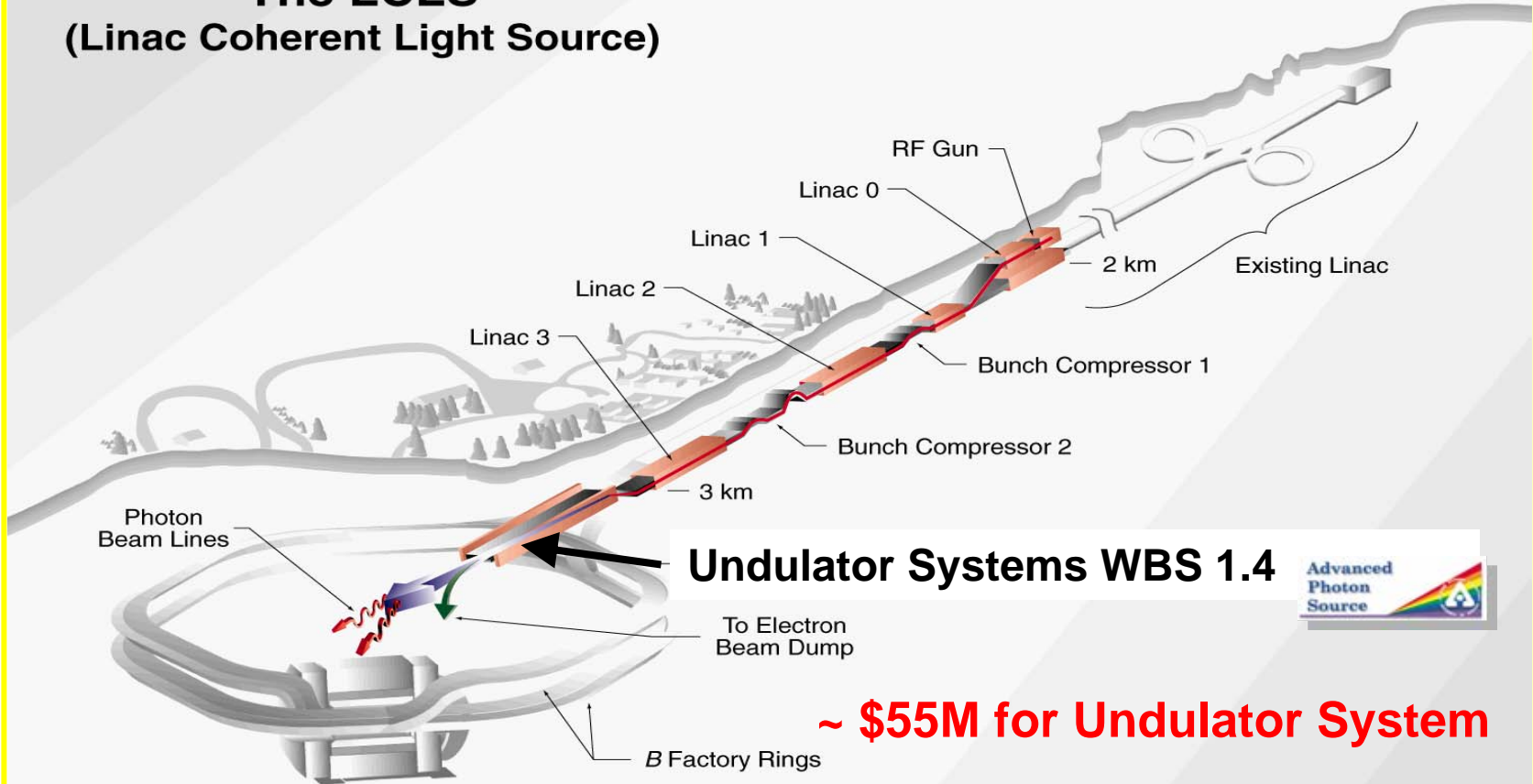

10-97
8360A1



Summary of Nominal Undulator Parameters

	May 2003	Today	
• Undulator Type	planar hybrid	planar hybrid	
• Magnet Material	NdFeB	NdFeB	
• Wiggle Plane	horizontal	horizontal	
• Gap	6.0	6.8	mm
• Gap Canting Angle	0.0	4.5	mrad
• Period Length	30.0 ± 0.05	30.0 ± 0.05	mm
• Effective On-Axis Field	1.325	1.249	T
• Effective Undulator Parameter K	3.630 ± 0.015%	3.500 ± 0.015%	
• Module Length	3.40	3.40	m
• Number of Modules	33	33	
• Undulator Magnet Length	112.2	112.2	m
• Standard Break Lengths	18.7 - 18.7 - 42.1	48.2 - 48.2 - 94.9	cm
• Total Device Length	121.0	131.9	m
• Lattice Type	FODO	FODO	
• Magnet Technology	PMQ	EMQ	
• Quadrupole Core Length	5	7	cm
• Integrated QF Gradient	5.355	3.000	T
• Integrated QD Gradient	-5.295	-3.000	T
• Average β Function at 1.5 Å	18	30	m
• Average β Function at 15. Å	7.3	10	m

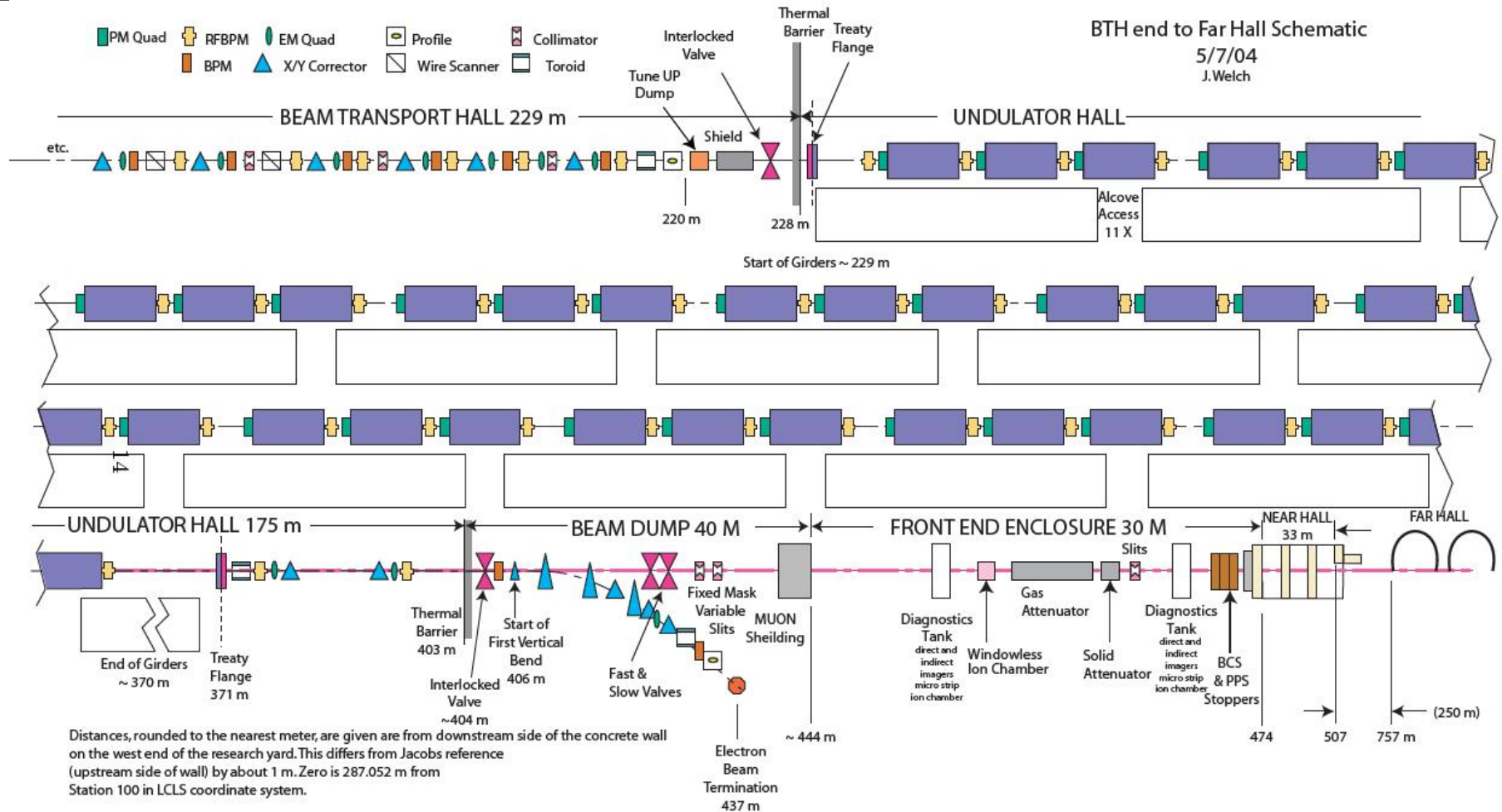

Distances, rounded to the nearest meter, are given as from downstream side of the concrete wall on the west end of the research yard. This differs from Jacobs reference (upstream side of wall) by about 1 m. Zero is 287.052 m from Station 100 in LCLS coordinate system.

Changes from 3/16/04 version:

Treaty flange locations are shown. Toroid moved to other side of treaty flange.

Dump line and Muon shielding moved 8 m upstream.

Prototype Undulator at ANL

Vacuum Chamber Goes in Here

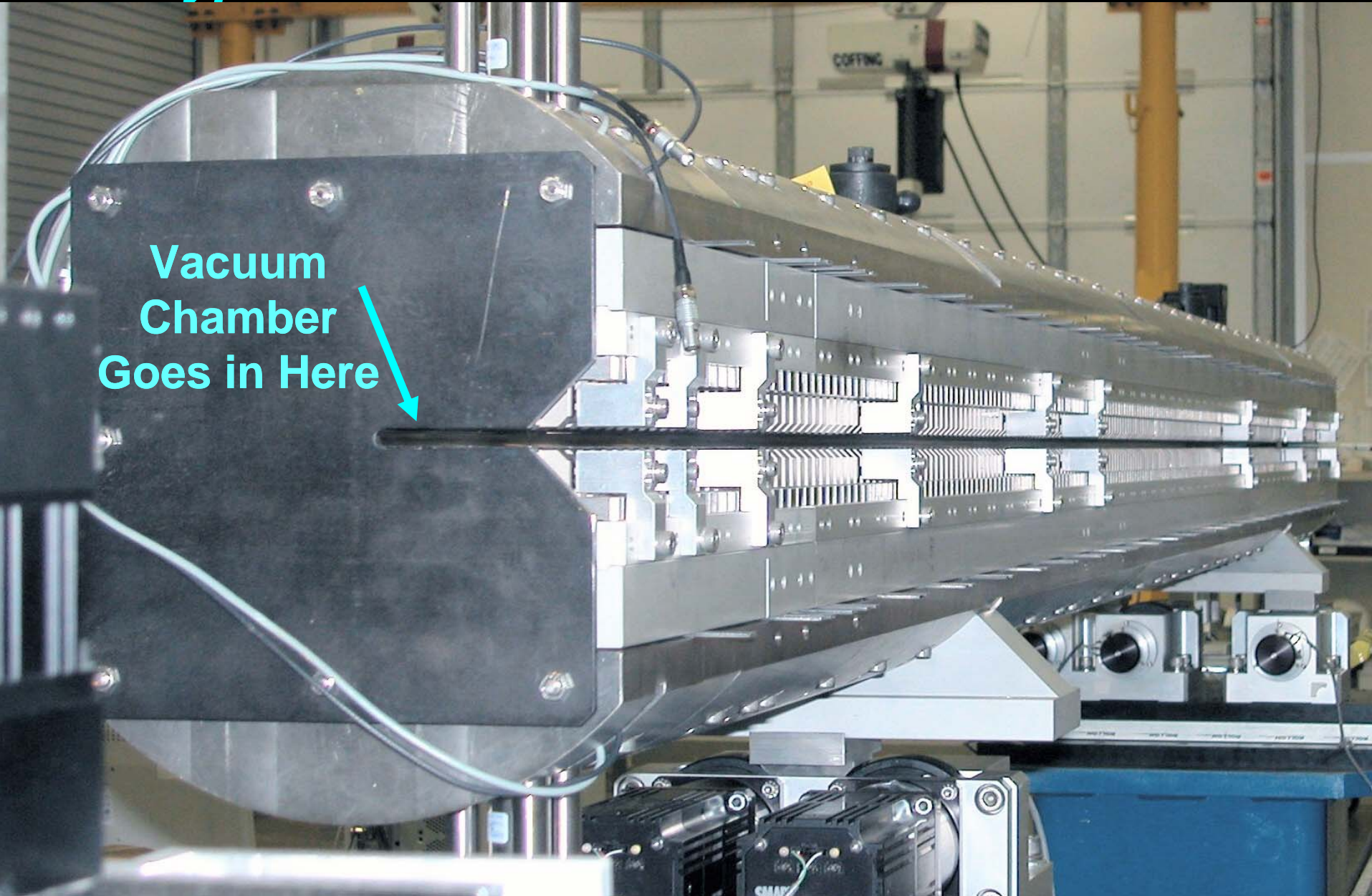

Support Assembly

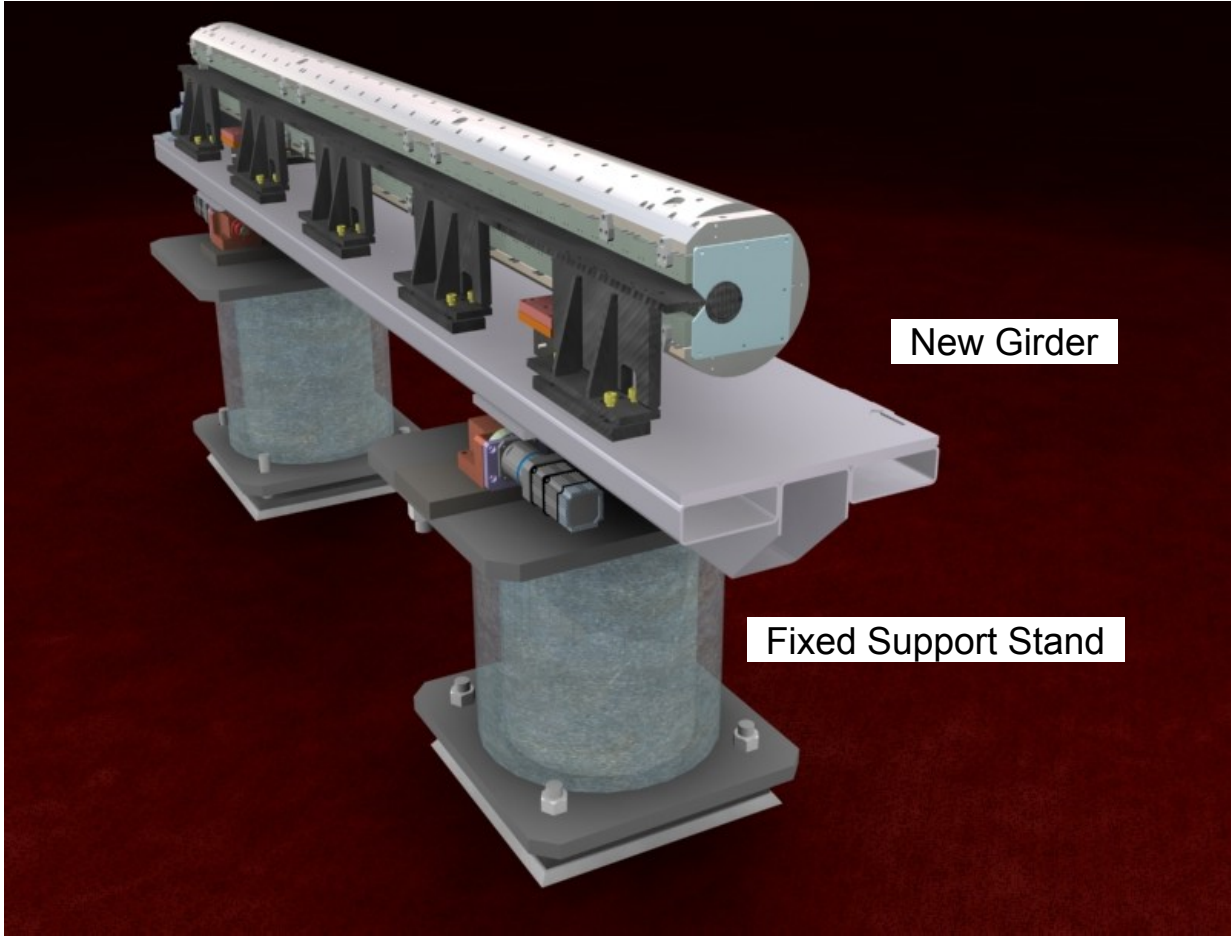

New Girder

Fixed Support Stand

Tolerance Budget

Error Source	$\langle \sigma_i \rangle$	$\langle \sigma_i \rangle f$	f_i	$\langle \sigma_i \rangle f_i$	Units
		$f=0.268$ (25% red.)		(24.2% red.)	
Hor/Ver Optics Mismatch $(\zeta-1)^{0.5}$	0.59	0.18	0.456	0.31	$\zeta < 1.1$
Hor/Ver Transverse Beam Offset	23	5.7	0.177	3.7	μm
Module Detuning $\Delta K/K$	0.051	0.016	0.402	0.024	%
Module Offset in x	952	301	0.125	140	μm
Module Offset in y	268	72	0.298	80	μm
Quadrupole Gradient Error	8.7	2.3	0.028	0.25	%
Transverse Quadrupole Offset	4.4	1.3	0.215	1.0	μm
Break Length Error	17.1	5.4	0.048	1.0	mm

Can be mitigated through steering.

APS vs. LCLS Undulators

- **Gap**
 - APS undulators have variable gap for tuning the wavelength with minimal gap of ~ 7.5 mm
 - The LCLS undulator gap is fixed and beam energy is used to tune the wavelength. The gap is roughly 6.5 mm
- **Period**
 - The APS undulator A period is 3.3 cm
 - The LCLS undulator period is 3.0 cm
- **Length**
 - APS undulators are typically 2.4-m long and there is roughly 80 meters installed to date
 - The LCLS undulators are each 3.4-m long and when the full 33-undulator system is installed in 2007 it will stretch out over 130 meters.

Undulator Challenges

- **K Control**
 - Must maintain K to within 1.5×10^{-4}
 - *Implies*
 - $\Delta T/T < +/- 0.2$ degrees C
 - $\Delta \text{gap}/\text{gap} < +/- 1$ micron
 - Will use a “Canted Pole”
- **Alignment Issues**
 - Quadrupoles must be “centered” to better than 1 micron
 - Undulator centers must be within 50 micron
 - *We expect natural motion to be roughly 2 microns/meter/day at the SLAC site*
 - We will use beam-based alignment with high precision RF beam-position monitors along with wire-position monitors and hydrostatic leveling systems
 - Temperature variations effect
 - *Strength of the undulators*
 - *accuracy of the BPMs and other monitors*
 - *Support structures*

Undulator Pole Canting

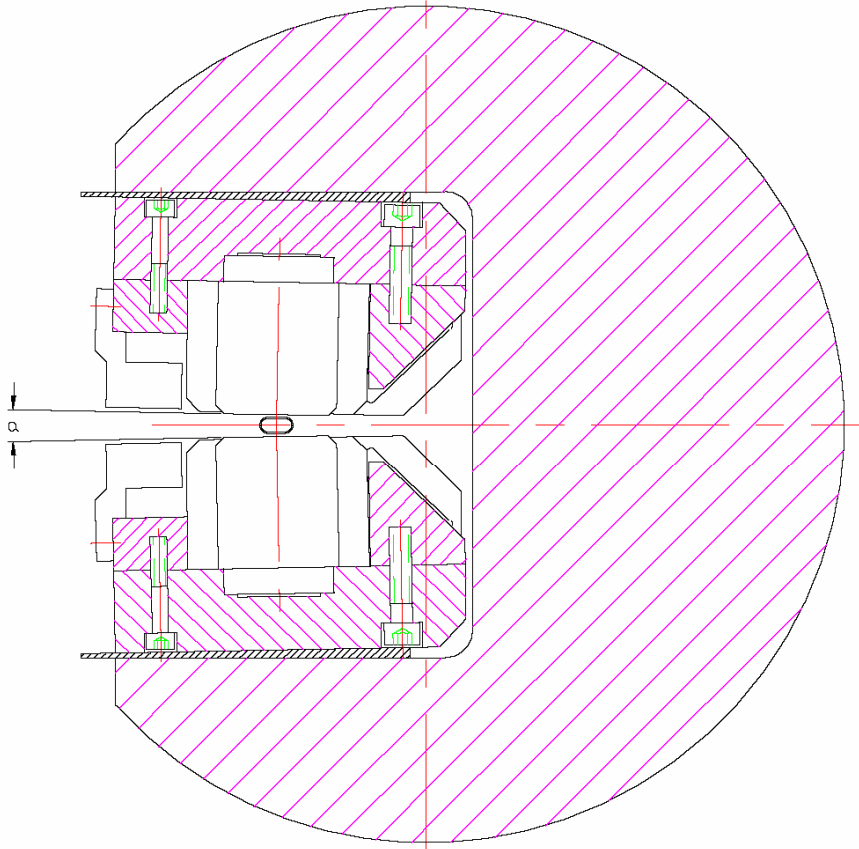

LCLS UNDULATOR CROSS SECTION WITH THE WEDGED SHIMS
(angle a is exaggerated)

- Canting comes from wedged spacers
- 4.5 mrad cant
- Gap can be adjusted by lateral displacement of wedges
- 1 mm shift means 4.5 microns in gap, or 8.2 Gauss
- B_{eff} adjusted to desired value

Courtesy of Liz Moog

Initial trajectory before any correction applied

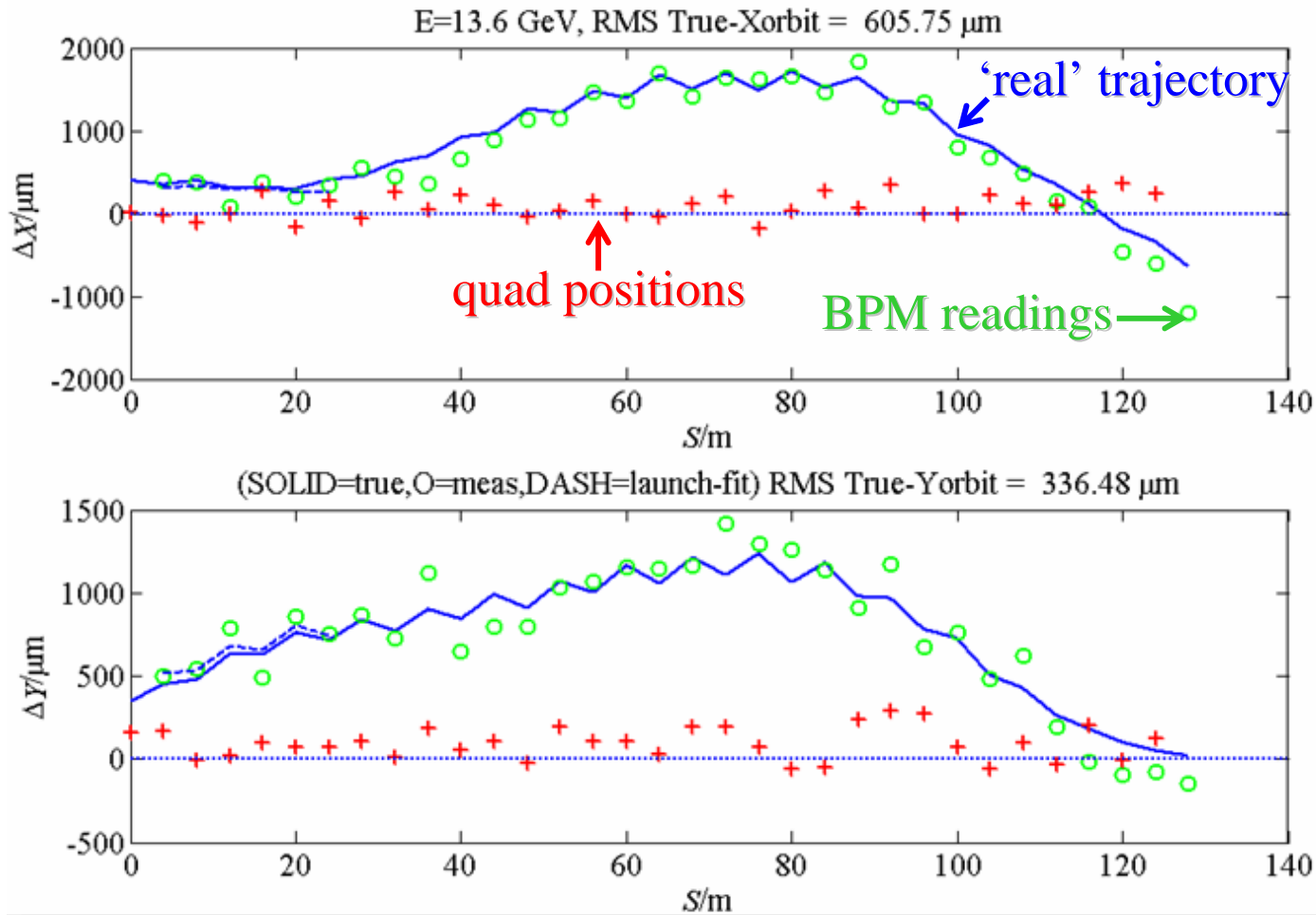

- + Quadrupole positions
- o BPM readback
- e^- trajectory

Courtesy P. Emma

25

BBA Procedure

- **Save BPM data at 14 GeV**
- **Change energy to 7 GeV (scaling linac magnets)**
- **Re-establish launch pos. & angle into undulator**
- **Save new BPM data at 7 GeV**
- **Repeat for 4.3 GeV (klystrons turned off in L3-linac)**
- **Calculate quad and BPM alignment corrections**
- **Move quadrupoles (only when $|\Delta x| > 7 \mu\text{m}$)**
- **Adjust BPM offsets in software**
- **Repeat entire process until trajectory change is $< 50 \mu\text{m}$ at 4.3 GeV (3 times initially, once for touchup)**

Courtesy P. Emma 26

After 3rd pass of BBA (13.6 GeV)

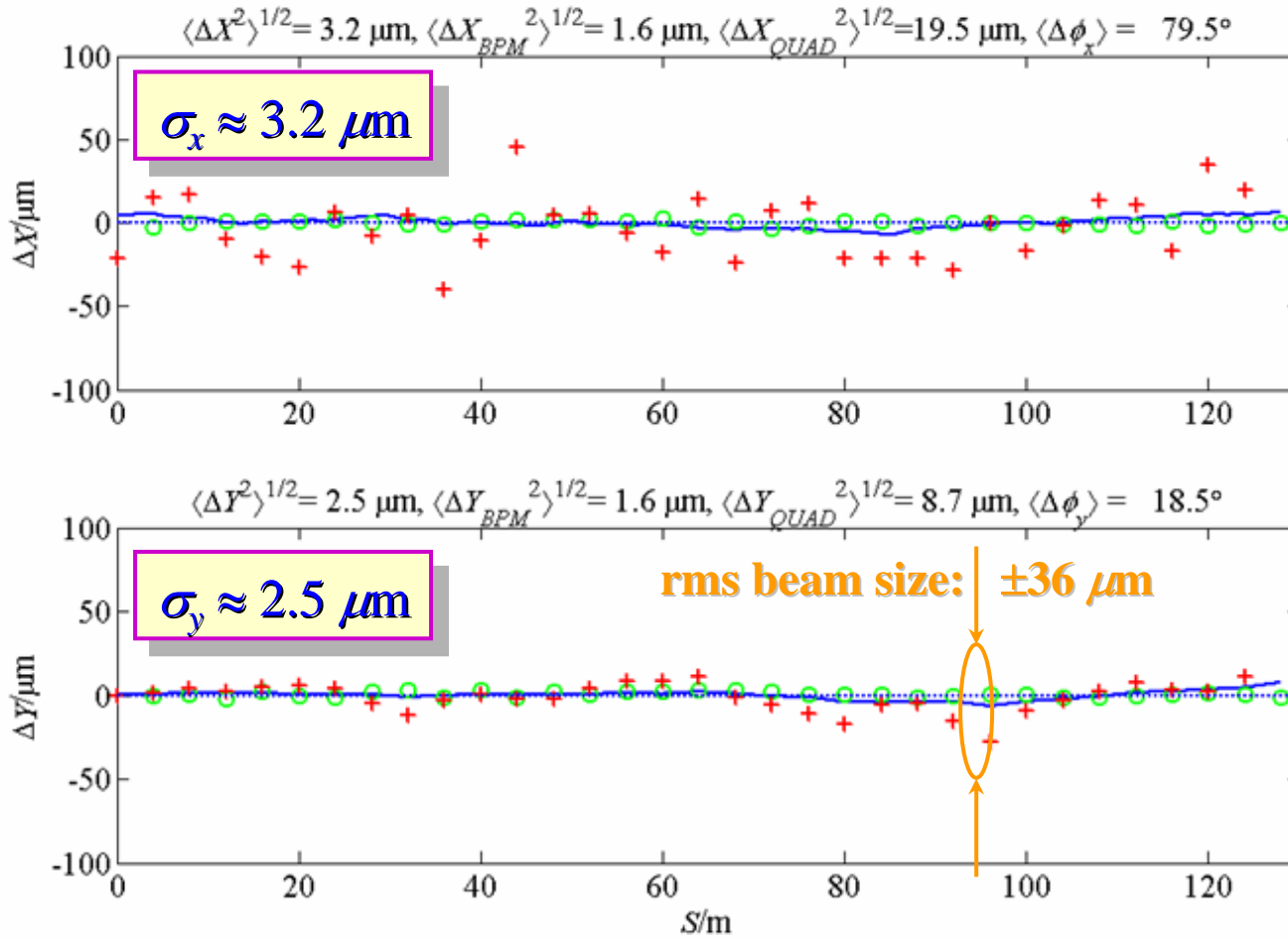

- + Quadrupole positions
- BPM readback
- e^- trajectory

$\Delta \phi \approx 98^\circ$

RON (FEL-code) simulation shows L_{sat} increased by <1 gain-length;
R. Dejus,
N. Vinokurov

Courtesy P. Emma



BPM Cavity Design

- 8 mm Beam Pipe dia. into BPM
- 10 mm BPM inner dia.
- Solid Copper Body
- WR-75 waveguide output
- Waveguide transition brazed to body

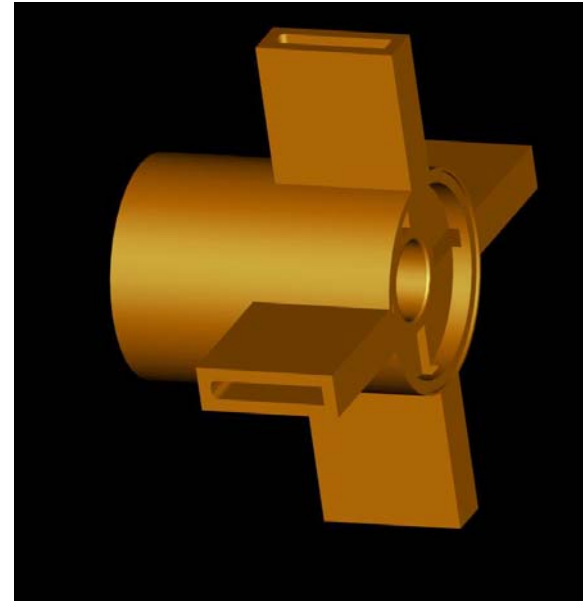
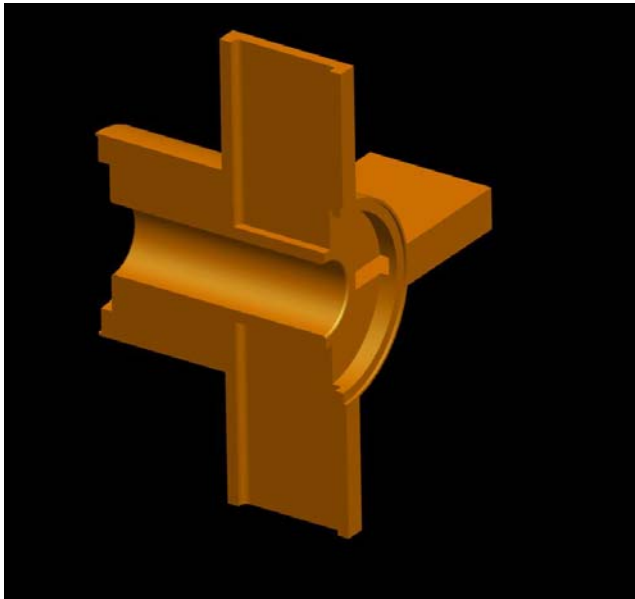

H-field Produced by 0.4 mm Horizontal Offset

- Waveguides are magnetically coupled to the cavity fields.
- Waveguide coupling is symmetric in each plane.
- Cross-talk contribution from the nonzero horizontal component of the hfield at ports 2 and 4 couples into waveguide.
- Cross-talk can likely be improved by reducing waveguide coupling and by reducing the waveguide height.

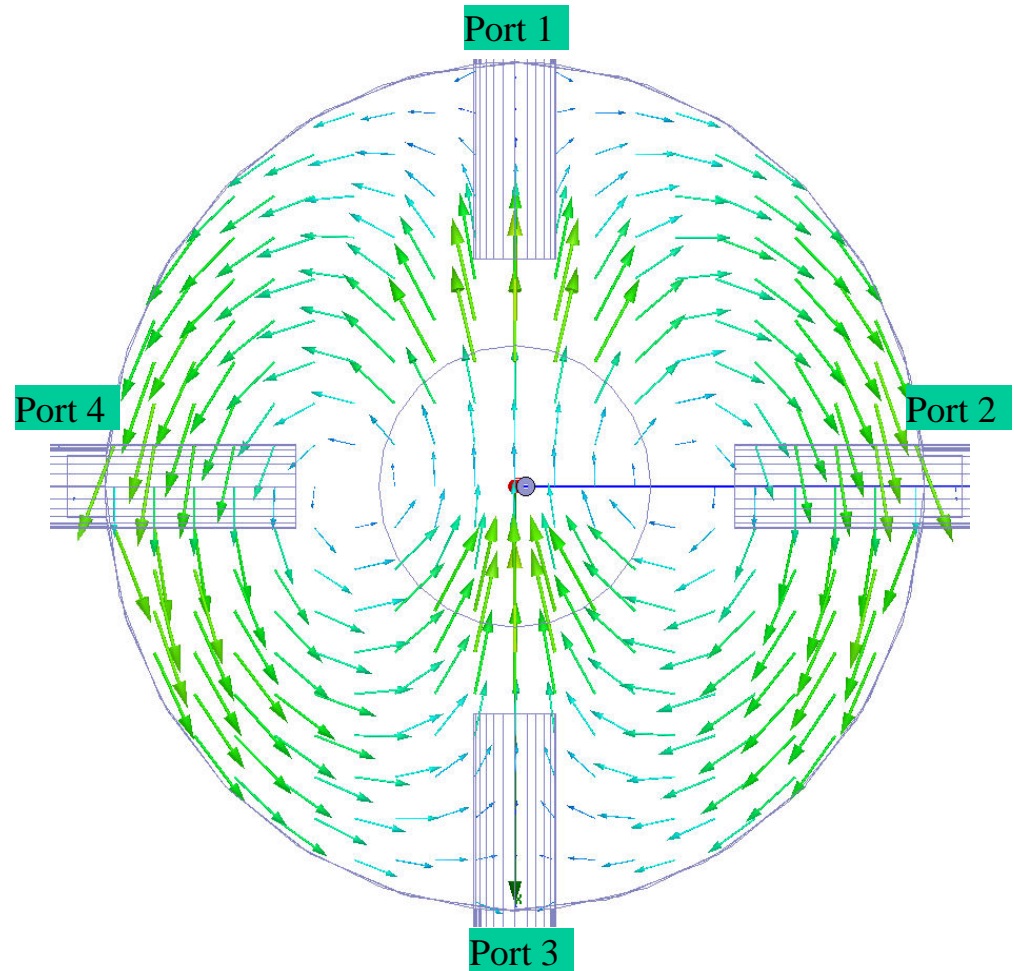

Courtesy G. Waldschmidt 29

Integrating Monitoring Systems into Cradle / Support System

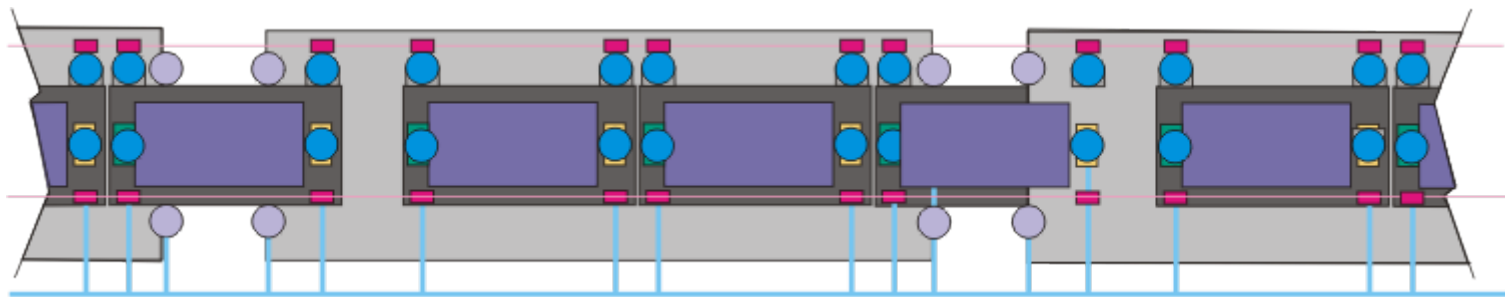

Since the cradle needs to be easily removable, we cannot attach the monitoring systems to it. Hence, both WPM and HLS need to be mounted to support table.

However, the mounting has to be accomplished in a way which will force the sensors to follow the cradle motion

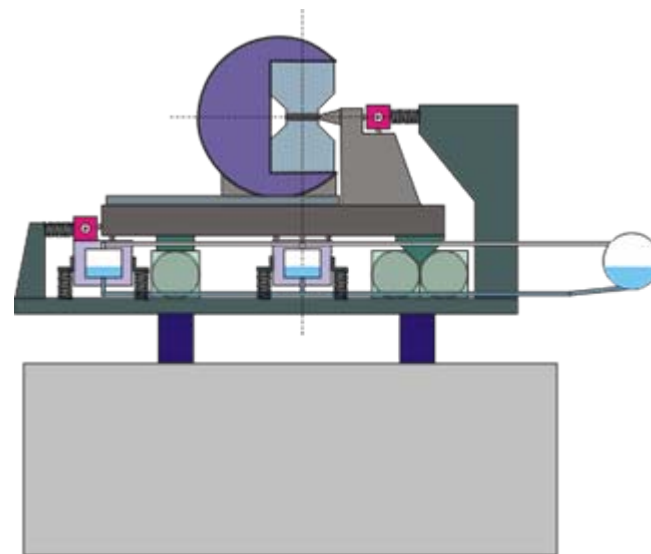

Courtesy R. Ruland 30

Major Events/Milestones

- **Undulators**
 - All major contracts will be awarded by the end of this week
- **Construction of Undulators**
 - Would like 1st article delivery in 2005 to ease the schedule
 - Must have assembly started beginning of FY06 (when construction funds arrive)
- **Magnet Measurement Facility (Built at SLAC)**
 - Need to get a magnet to them soon (by end of calendar year) to begin initial controls integration
- **33rd Magnet Arrives**
 - March 07
- **End of 2007**
 - Expect undulator system installation complete

Summary

- **The LCLS will be the first X-Ray Free-electron Laser**
- **Argonne's Role is two-fold**
 - We are responsible for delivery and validation of the complete 130-m+ undulator system
 - Our scientists are already actively participating and leading the development of some of the first exciting pioneering experiments that will be performed on the LCLS
- **We expect 1st scientific results in 2008**