



... for a brighter future

High-brightness CW ERL Gun R&D

K. Harkay

*APS/Users Monthly Operations
Meeting*

Dec. 13, 2006



U.S. Department
of Energy

UChicago ►
Argonne_{LLC}



Introduction

- ERL requirements **very** demanding on electron gun
- Grand challenges:
 - Extremely low emittance AND
 - High average current
- Physics and engineering of high brightness guns have long been pursued – performance achieved but at low duty factors
- Interest in high-average-power FELs and ERLs is driving a vigorous CW gun R&D effort world-wide

Thanks to Manoel Conde, John Lewellen, Yuelin Li, Ali Nassiri, Yin-e Sun, and Marion White for discussions and input

Representative ERL gun requirements

Cornell ERL Parameters¹ Scaled to 7 GeV

	APS now	ERL		
		High flux	High coherence	Ultrashort pulse
Average current (mA)	100	100	25	1
Repetition rate (MHz)	0.3~352	1300	1300	1
Bunch charge (nC)	0.3~60	0.077	0.019	1
Emittance (nm)	3.1 x 0.025	0.022 x 0.022	0.006 x 0.006	0.37 x 0.37
Rms bunch length (ps)	20 ~ 70	2	2	0.1
Rms momentum spread (%)	0.1	0.02	0.02	0.3

[1] G. Hoffstaetter, FLS 2006 Workshop, DESY

- Promise of very high brightness due to very low emittance & energy spread, even for 25 mA
- Different modes may not use the same gun

Slide courtesy M. Borland, MAC presentation

Anatomy of an ERL gun/injector

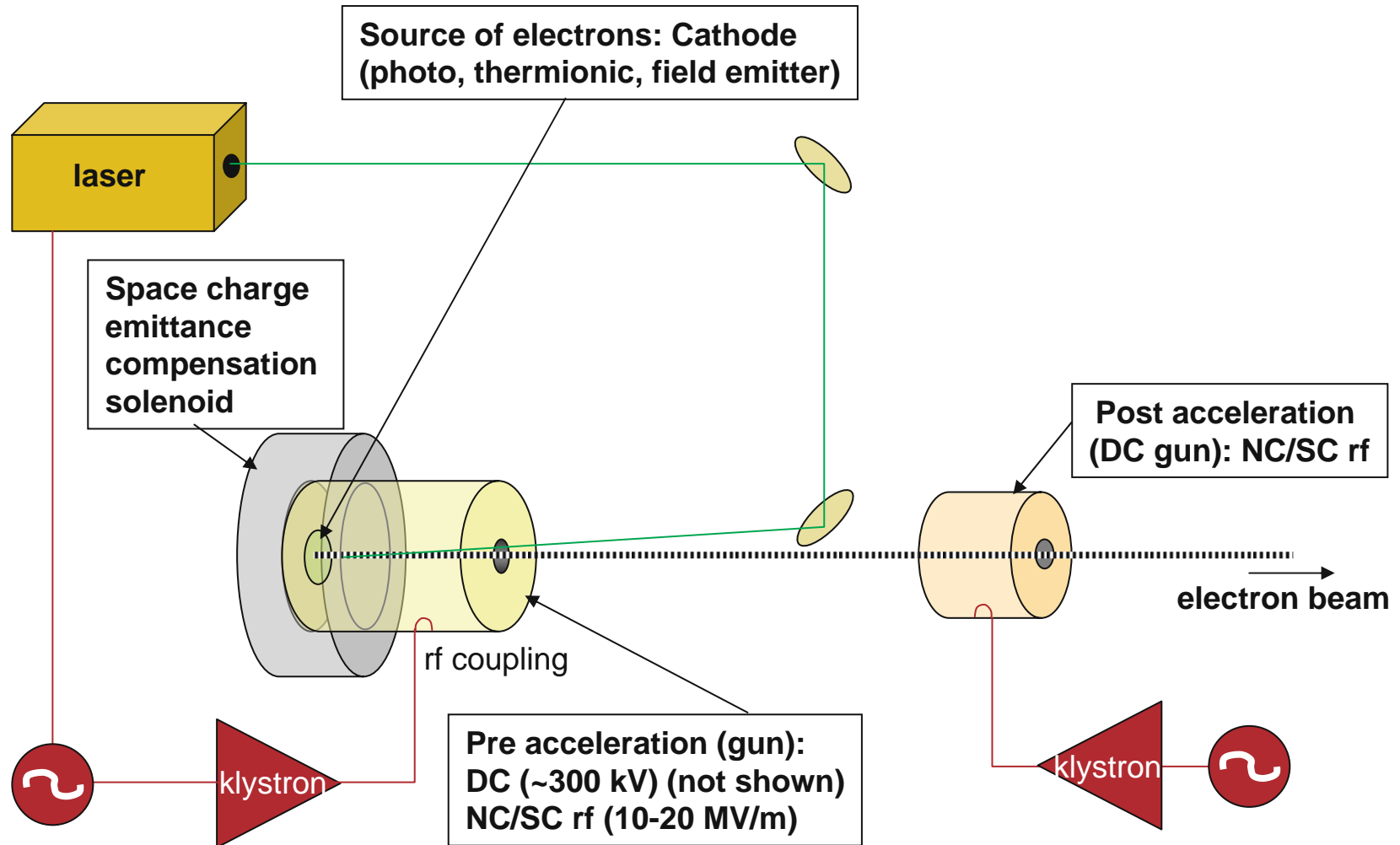

Schematic adapted from D.C. Nguyen, LANL

	Operational ERL guns			ERL guns under commission	
Facility	JLab ERL FEL	JAERI ERL	BINP ERL FEL	Daresbury ERLP	Cornell ERL
Gun type	DC	DC	DC	DC	DC
Voltage (kV)	350	230	300	350	300 (750)*
Cathode	photocathode (GaAs)	thermionic	thermionic	photocathode (GaAs)	GaAs or GaAsP
Average current (mA)	10	5	20 ~ 40	6.5	100*
Beam energy after booster (MeV)	7~10	2.5	2	8.35*	5 ~ 15*
Booster type	SC rf	SC rf	NC rf	SC rf	SC rf
Booster frequency (MHz)	1497	499.8	180	1300	1300
Norm. rms emit (μm)	<10	30	32	1.5*	<1*
Note				first beam in 08/2006	first beam 09/2006

$\epsilon = 0.07 \text{ nm @ 7 GeV}$

Normalized emittance $\epsilon_N = \epsilon\gamma = \epsilon(14000)$

* design values

DC gun challenges

- Photocathode QE, lifetime
- XUHV req'd, < 0.1 nT
- Space charge emittance compensation (solenoid)
- Voltage breakdown issues – high standoff ceramic
- Power supply: $100\text{mA} \times 750\text{kV} = 75$ kW
- Drive laser or high voltage pulser or buncher
- Safety, reliability, stability

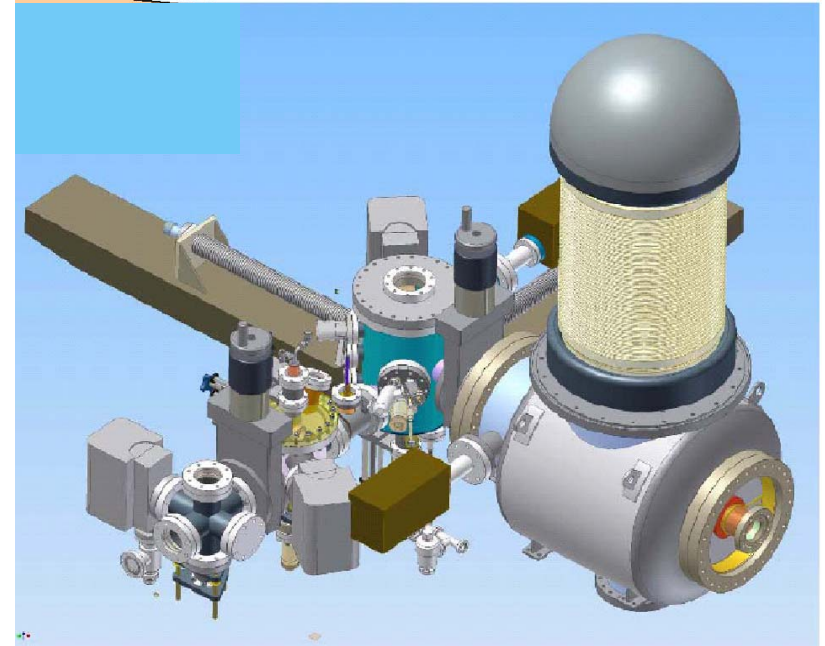

Cornell DC gun + SC rf booster (S. Gruner)



	ERL guns under development			
Facility	Rossendorf, Germany	LANL/AES	BNL/AES	Peking Univ., China
Gun type	SC rf	NC rf	SC rf	DC + SC rf
Gun frequency (MHz)	1300	700	703.75	1300
Cathode	Cs ₂ Te	multi-alkali	multi-alkali /diamond	Cs ₂ Te
Average current (mA)	1	100	500	1.6 -- 5 (0.27 achieved)
Norm. rms emit (μm)	0.5 – 2.5	6	2	3 – 5 (achieved)
Energy at gun exit (MeV)	9.5	2.5	2	2.6 (1.1 achieved)

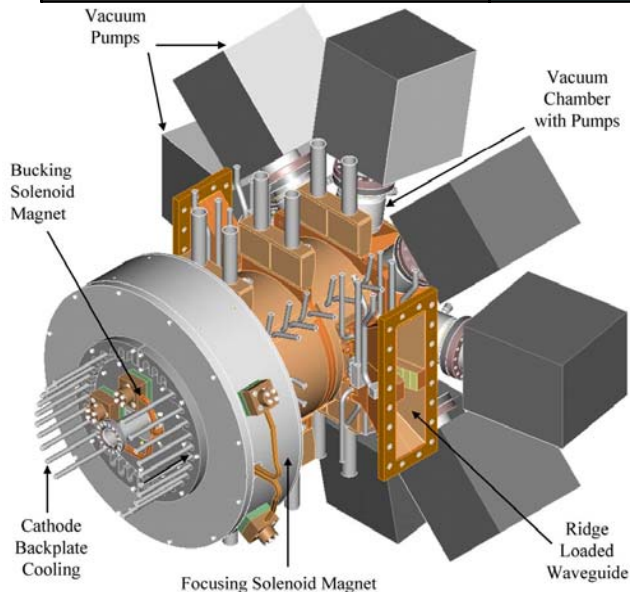

Compiled by Y.-E. Sun

Predecessor holds record: 32 mA, $\epsilon_N \sim 7\mu\text{m}$

Thermal/vacuum management:
100 mA NC rf gun dissipates 800 kW!

SC RF gun challenges

- Least mature, most promising
- Cathode compatibility with rf and SC environment
- Thermal isolation and integration of cathode (laser power) with cavity
- Emittance compensation: magnetic shielding req'd, can't use solenoid
- Drive laser
- Reliability
- ...

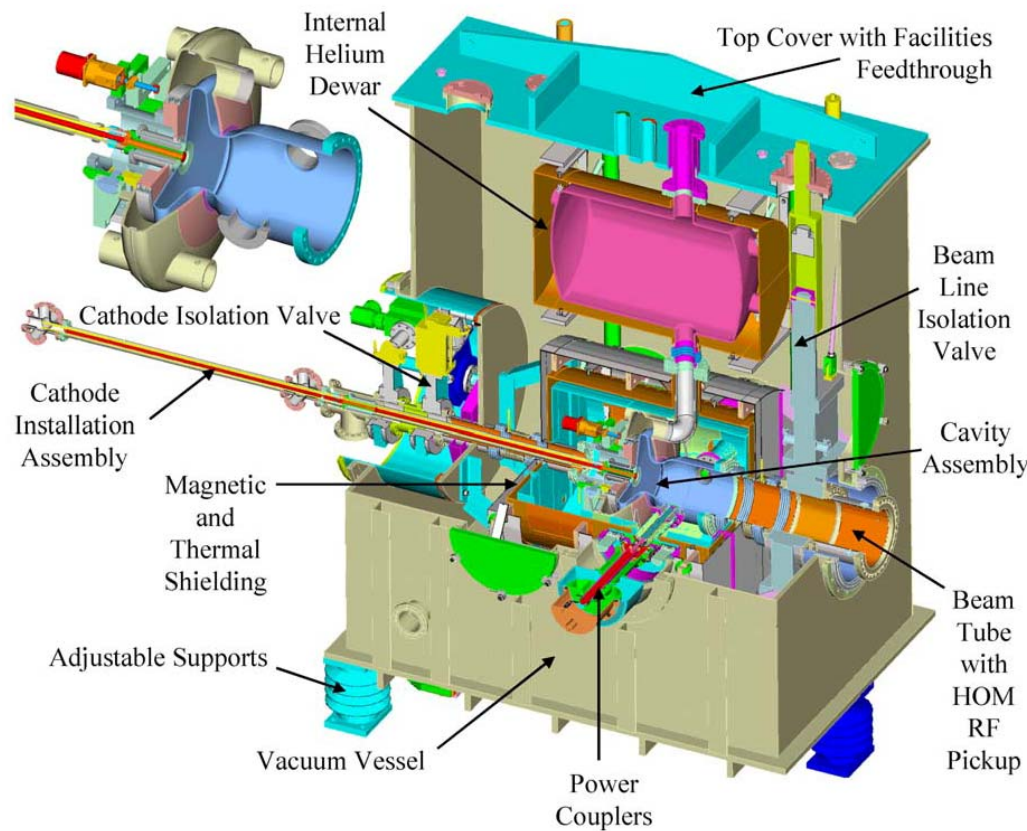

AES/BNL SC rf gun (A. Burrill et al)

Towards R&D program at APS: expertise/facilities

■ APS

- Laser physics, gun dynamics theory and modeling, NC/SC rf, Injector Test Stand, photocathode NC rf gun operation for LEUTL, engineering, photocathode theory

■ Argonne

- HEP, Advanced Wakefield Accelerator group: high QE photocathodes, NC rf gun, modeling and design
- PHY: SC rf
- AST-ONR: CW guns, high avg power FELs (Navy)
- MSD: cathodes, ceramics

■ Local area

- FNAL: high brightness injector, ILC R&D, dynamics, SC rf
- Universities: NIU, ...

Summary

- ERL CW guns extremely challenging: pushing significantly beyond present state-of-the-art
- Performance goal: to achieve very low emittance and high average current
- R&D is vigorously being pursued world-wide; planning at APS underway
- All are welcome to attend ERL Journal Club (send me email):
http://www.aps.anl.gov/Accelerator_Systems_Division/Accelerator_Physics/