

APS Update

R. Gerig/D. Mills

September 23, 2011

Agenda

- 2:30 p.m. Refreshments
- 2:45 p.m. APS Update – Rod Gerig
- 3:10 p.m. APS-U Update – Derrick Mancini
- 3:25 p.m. 34-ID Canting Upgrade – Paul Zschack
- 3:45 p.m. Adjourn



Chemical Clean Sweep for APS

- We are pleased to announce the continuance of our “Clean Sweep” effort for chemicals at the APS. The Chemical Clean Sweep goal is the removal of Unneeded and Unwanted Chemicals to create a safe and more efficient work environment throughout Argonne National Laboratory. These chemicals will be taken at no cost and will require no waste requisition to be completed.
- We will accumulate materials between now and COB on October 8, 2011.
 - Materials that will be accepted are only unneeded and unwanted chemicals in their original labeled containers.
 - Simply mark the bottle with your contact information
 - Contact Paul Rossi (4-4492) or a Floor Coordinator (2-0101) to arrange a time when the chemicals can be dropped off at building 437 Room C002.



Reminder: Beamline Management Safety Meetings

- Laboratory director requested all ALDs to hold meetings with all managers regarding recent Argonne safety incidents and need for ALD safety action plan
- APS management meeting held on August 4
- APS managers requested to meet with their staff by September 2 (completed)
- E-mail sent to Non-Argonne beamline principle contacts on August 5
 - Provided copies of August 4 meeting agenda and APS safety action plan
 - Requested beamline managers hold similar meetings by September 30
 - **Send Tom Barkalow email notification that meetings have been held (date, time, and any safety suggestions which may have resulted)**
 - Have had confirmations from two beamlines that meetings have been held
 - **Need to receive additional confirmations by COB September 30**



APS News

- Brian Stephenson was appointed APS Director, and Photon Sciences Associate Laboratory Director, effective September 1.
- September shutdown coming to an end, User Operations begin Tuesday, Oct. 4.
- The APS Scientific Advisory Committee meeting is October 12-13
 - APS Update
 - APS-U update (roadmap, hiring plan, expected activities during the next six months or so)
 - Dynamic Compression Sector update
 - New LOIs?
 - Beamline data from CATs and XSD / discussion of future Sector Review processes



APS Reviews

- The Office of Basic Energy Sciences review of the APS took place September 12-15
 - The review consisted of presentations by APS management and users, but also included a number of informal meetings between the reviewers and staff
 - The close-out was encouraging; a theme of the comments was a desire for more communication of an informal nature; transparency in setting priorities
 - The written report is expected in several months

- We have received the written report (held July 2011) from the UChicago Argonne LLC Review Committee.
 - Comments overall were very positive and constructive
 - Many of the recommendations dealt with the APS-U project including:
 - Detailed scientific case for SPX needs to be well articulated and communicated at various levels
 - Use of contingency funds will need to be communicated in a transparent fashion
 - It is important that the entire APS staff feels personal responsibility for the success of the upgrade project and leadership should pursue informational and team-building efforts



Canted Beamlines at the APS

- Shutdown work in storage ring is complete
 - HP-CAT (16-ID) conversion to canted ID FE completed and two IDs installed.
- We continue to use shutdowns to demonstrate and verify that “upgrade like” work can be performed during these standards shutdowns.
- The front end **replacement** and canted undulator installations at 16-ID and 34-ID are examples of such work.

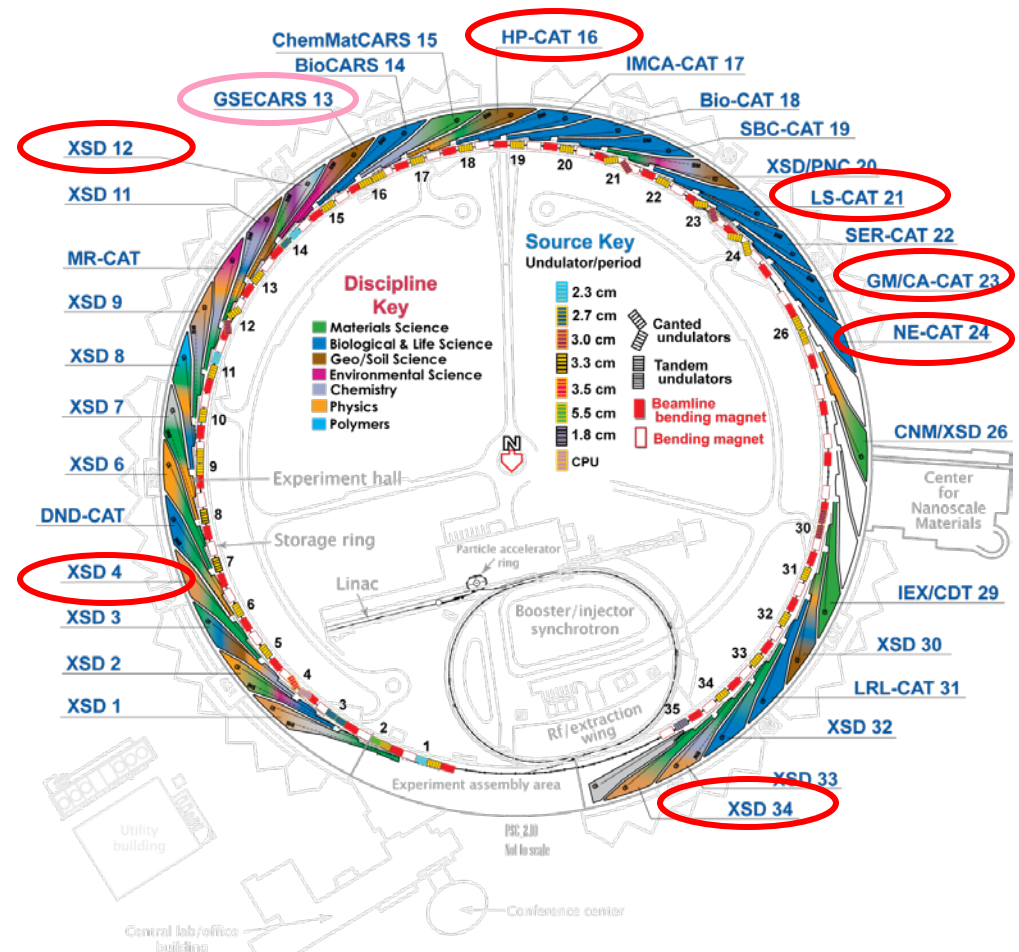

“Synchrotron Research in Cultural Heritage Science” Seminar Scheduled for Oct 11-12

This event is part of a continuing series of seminars on conservation science, a vital element of the Art Institute of Chicago/Northwestern University Collaborative Program in Conservation Science supported by the Andrew W. Mellon Foundation.

The upcoming meeting is also carried out in partnership with the Advanced Photon Source of Argonne National Laboratory.

The goal of these seminars is twofold:

- to educate scientists and engineers on the opportunities and unsolved problems in conservation science
- to inform conservators, curators and conservation scientists about the techniques and expertise available in science and engineering which might be brought to bear on conservation science problems.

Participation is free, **but you need to register in order to attend.**

E-mail mrc@northwestern.edu by Monday

Info at <http://www.matsci.northwestern.edu/aic/>
or contact Volker Rose vrose@anl.gov

The Art Institute of Chicago/ Northwestern University Joint Seminar Series
On Conservation Science in Partnership with the Advanced Photon
Source of Argonne National Laboratory :

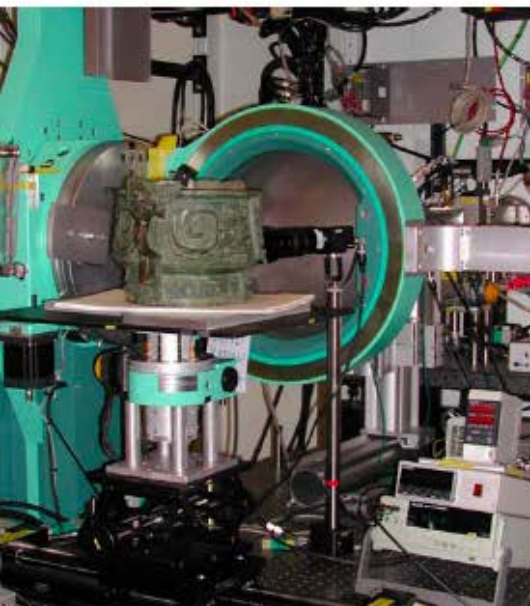

“Synchrotron Research in Cultural Heritage Science”



Argonne and Evanston, IL ,
October 11 and 12, 2011

- Tuesday, October 11 (10:30 am – 5:30 pm)
Advanced Photon Source, Argonne National Laboratory, Argonne, IL, Room A1100, Bldg. 401 (APS)
- Wednesday, October 12 (9:00 am to 1:00 pm):
Ford Engineering Design Center, Northwestern University, Evanston, IL ITW classroom



APS-U Update

D. Mancini/D. Mills
September 23, 2011

APS-U Goings On

- CD-1 signed by B. Brinkman on September 15, 2011 (hence the pizza lunch today).
- We are working on getting the members on board for the Stakeholders Committee.
- Refurbishing of Building 314 is nearly done and we expect beneficial occupancy soon.
- First meeting was held to discuss various options for expansion of LOMs.

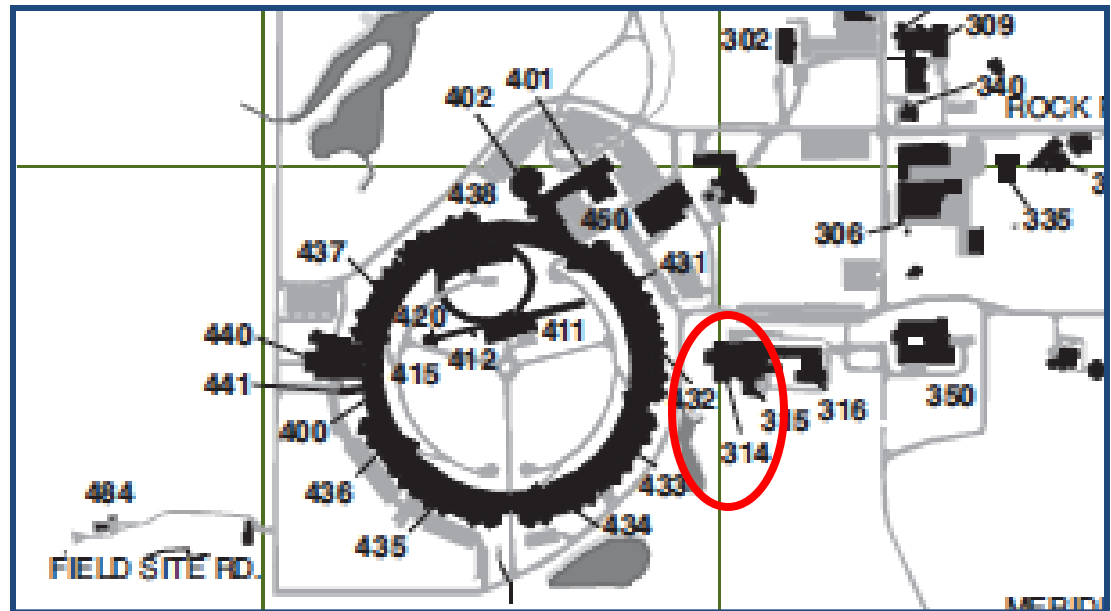

Roadmap Work Process Flow

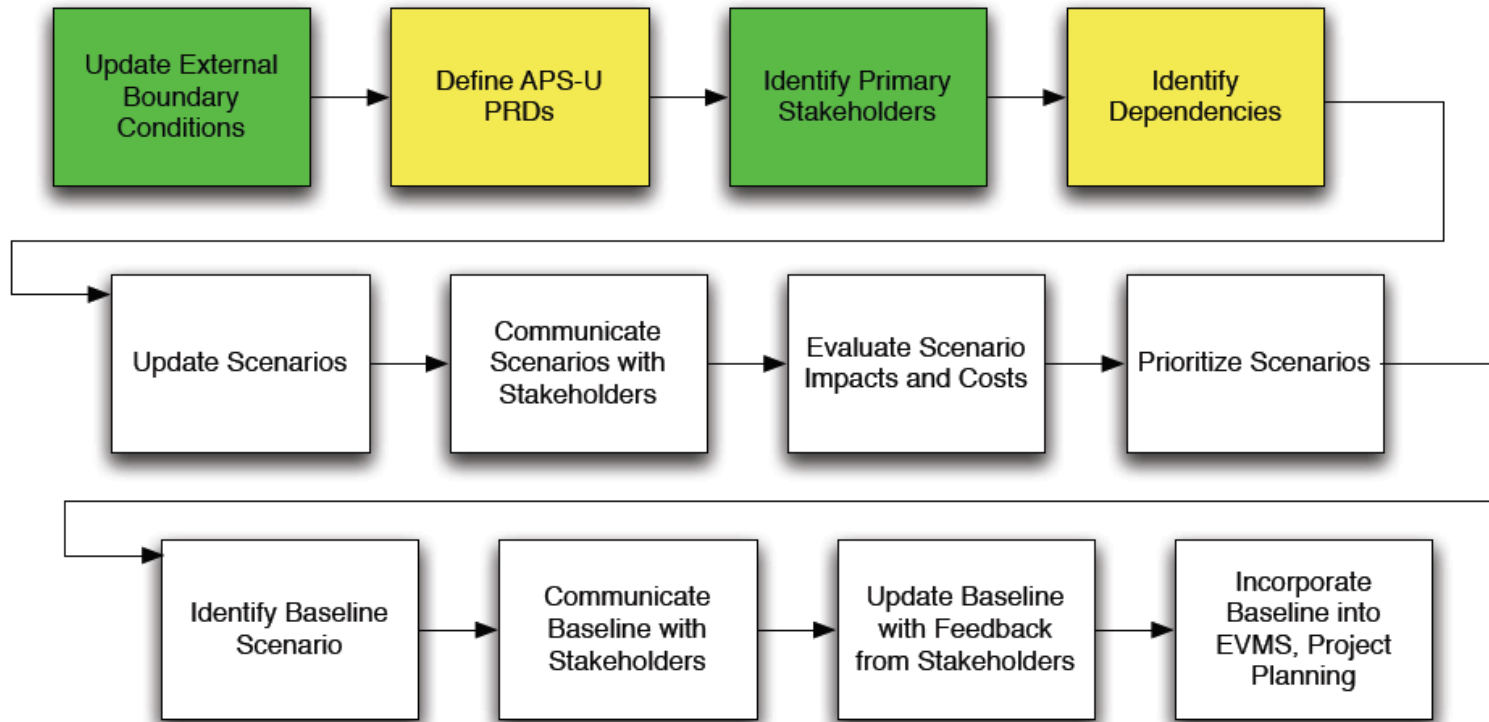

- Road-mapping discussions between APS-U team and BL Staff/Stakeholders is ongoing to collect data/information.
- Draft Physics Requirements Documents (PRDs) have been submitted by all in-project beamlines. We hope to finalize the drafts and get them out for sign offs by Oct. 4.

Dynamic Compression Sector (DCS)

- Although not a component of the APS-U Project (funded separately by DOE/ National Nuclear Security Administration – NNSA), APS will be managing the construction of the beamline.
- Yogi Gupta from Washington State University, will be the PI responsible for the development of the instrumentation in the hutches.
- Even though it is not part of the project, this needs to be folded into our Road-mapping exercise.

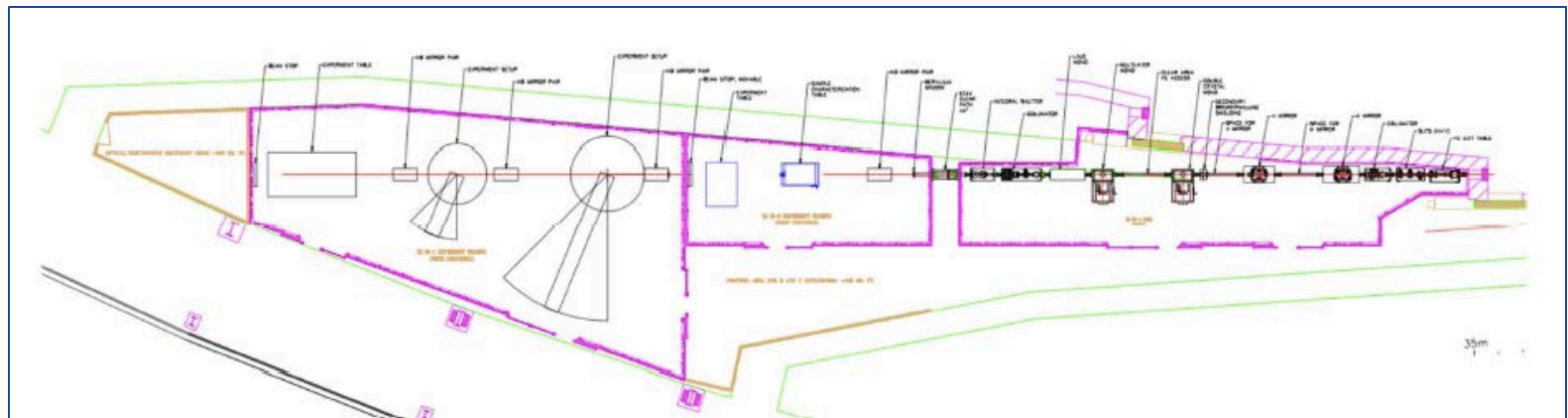

Dynamic Compression Sector (DCS)

- DCS Program:
 - In-situ, time-resolved measurements at microscopic length scales constitute the overarching scientific need for achieving a fundamental understanding of time-dependent materials phenomena
 - Dynamic compression experiments are uniquely suited to produce extreme states of interest
 - Dynamic compression experiments permit real-time examination of materials phenomena
 - Hard X-ray sources are ideally suited to achieve in-situ measurements

