

Undulators for APS-U

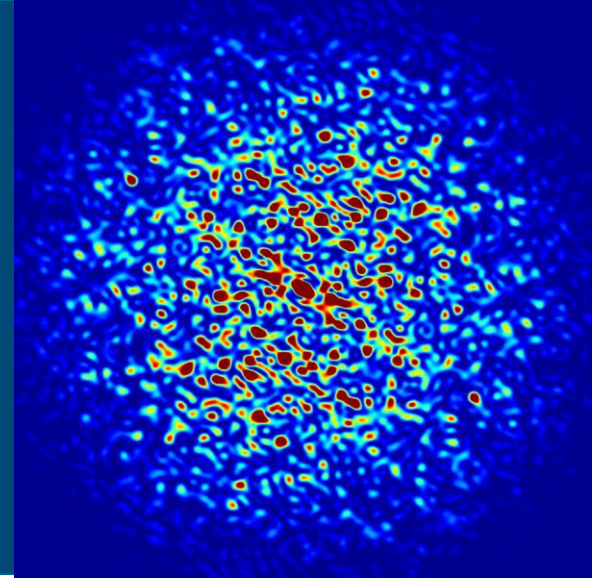

Roger Dejus

On behalf of the APS-U team

ASD Seminar September 19, 2018

Outline

- Staff/organization chart
- ID scope
- ID brightness tuning curves (APS-U vs. APS)
- Requirements & interfaces
- Design maturity and challenges
- Long lead procurements
- Summary

Insertion Devices Organization Chart (APS-U Project)

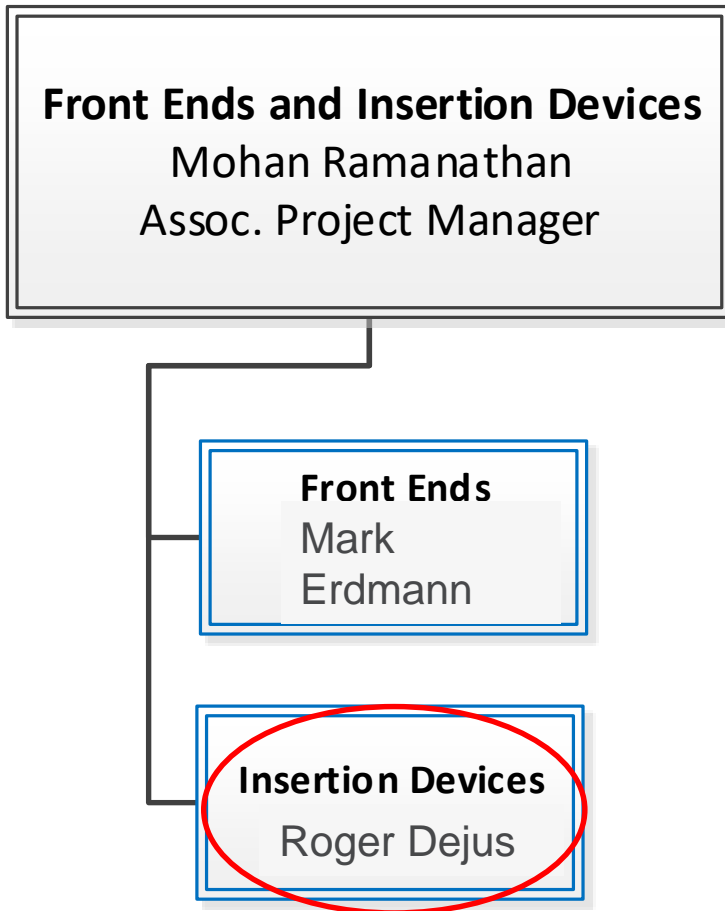

Key ID Project Team Members:

- Melike Abliz, APS-U
- Ethan Anliker, AES-DD
- Joel Fuerst, ASD-MD
- John Grimmer, ASD-MD
- Yury Ivanushenkov, ASD-MD
- Matt Kasa, ASD-MD
- Jason Lerch, AES-MED
- Liz Moog, ASD-MD
- Oliver Mulvany, AES-DD
- James Mulvey, AES-DD
- Megan Szubert, AES-DD

ID Scope Overview

- Scope includes design and fabrication of 4 new Hybrid Permanent Magnet Undulator (HPMU) periods (40 units), 2 new SCU periods (8 units); (HPMU -> uses both poles and permanent magnets)
- All HPMU 2.7-cm periods and some of the 3.3 cm, 3.0 cm, and 2.3 cm IDs will be reused (20 units)
- Phase shifters and canting magnets
- Longer SCU magnet cores and longer cryostats
- New ID Vacuum Chambers (IDVCs)
- Reuse all existing Gap Separation Mechanisms (GSMs) – major cost saving
 - New special-purpose GSMs will be designed to meet specific needs (e.g., fast scanning)
- IDs will be tuned to meet a $\sim 3^\circ$ RMS phase error (if requested) and many will be ready before the shutdown period begins (planned for May 2022). Others will be pre-tuned waiting for GSMs to be removed from the storage ring and undergo final tuning during the dark period.

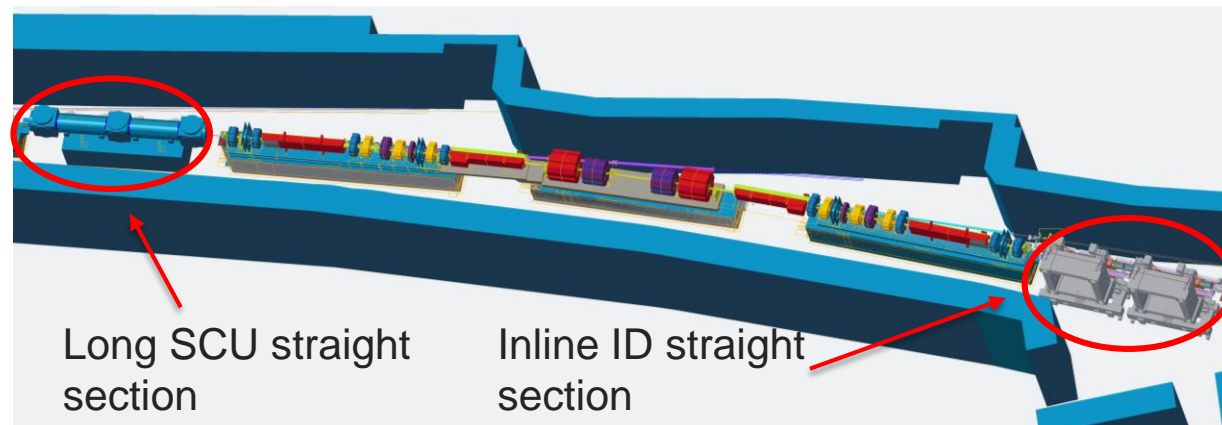

Insertion Devices Scope

Device	IDs Requested	Comments
Planar Hybrid Permanent Magnet Undulators (HPMUs)	42	<ul style="list-style-type: none"> 23 new IDs with 4 new periods: 2.8, 2.5, 2.1, 1.35 cm 19 existing IDs: reuse all 2.7 cm periods and some 3.3, 3.0 and 2.3 cm periods; now including two 3.0 cm periods for SCAPE
Revolver HPMUs	9	<ul style="list-style-type: none"> 8 new twin-head revolvers with new periods (2.5/2.1) cm 1 existing twin-head ID: reuse/new (2.3/1.35) cm
Super Conducting Undulators (SCUs)	9	<ul style="list-style-type: none"> 6 new SCUs with 1 new period: 1.65 cm 2 new SCUs with 1 new period: 1.85 cm 4 new long cryostats (~4.5 m) 1 existing 1.8-cm-period SCU (short cryostat)
Electromagnetic Variably Polarizing Undulator (EMVPU)	1	<ul style="list-style-type: none"> 1 existing 12.5-cm-period ID (IEX - Intermediate Energy X-ray) for low energy x-rays
Variably Polarizing SCU (SCAPE)	0	<ul style="list-style-type: none"> Off project: 2 new ~3.5-cm-period IDs in one new long cryostat for polarization switching studies -> replaced by HPMUs

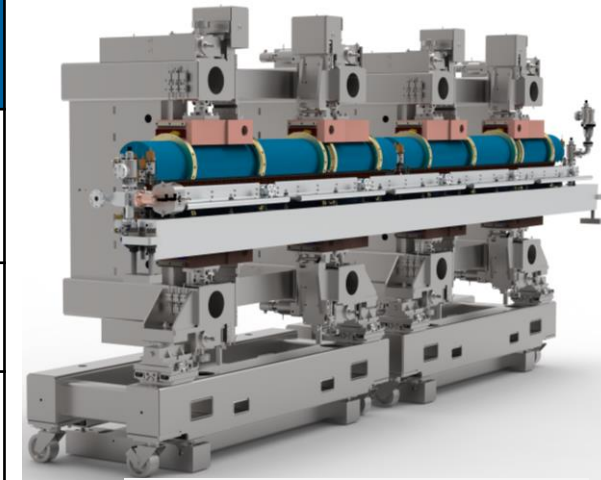

Two tandem revolver IDs

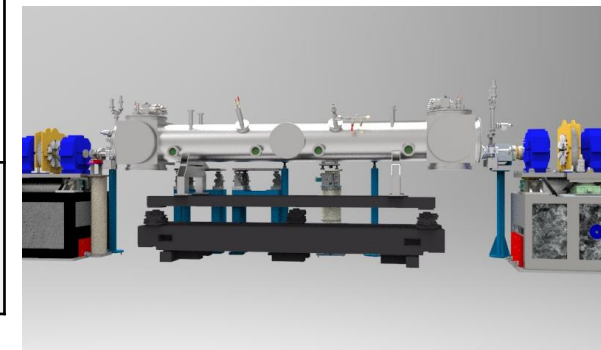

Design model of APS-U SCU cryostat in ID straight section

Total count of **new/reused** planar HPMU magnet structures: **40/20**; **total HPMUs 60**

Total count of **new/reused** planar SCU magnet structures: **8/1**

Total count of APS-U magnet structures including SCUs and IEX: **70**

Both planar and revolver undulators will reuse the existing gap separation mechanisms (“harvested” during dark time)

Sector ID Selections

Sector	Affiliation	v2 FE type	Comments	v2	v2	Phase Shifter	Center Corrector	Center CM	Half CM
				ID1	ID2				
1		HHL	Two SCU in 1 cryostat in tandem (~1.75 m each) with Phase Shifter and corrector	SCU1.65	SCU 1.65				
2		CU	Canted 2.1m long devices - Need Canting magnets, BPM	Planar 2.8*	Planar 2.8*		1	1	2
3		HHL	Two planar devices in tandem (~2.4m each) with a Phase Shifter and corrector	Planar 2.5	Planar 2.5	1	1		
4		HHL	Two SCAPE devices in 1 cryostat in tandem (May need Phase shifter)	Planar 3.0	Planar 3.0	1	1		
5	DND	HHL			Planar 3.3				
6		CU	One Planar and 1 existing 1.1 m SCU - Need half length chambers	Planar 2.7*	SCU 1.8*		1	1	2
7		HHL			Planar 2.8				
8		HHL	Two revolvers in tandem (~2.4m each) with Phase Shifter and corrector	Rev 2.5/2.1	Rev 2.5/2.1	1	1		
9		HHL	One planar and one Revolver in tandem with Phase Shifter and corrector	Planar 2.1	Rev 2.5/2.1	1	1		
10	MR	HHL	Need full tunability fast scanning		Planar 3.3				
11		CU	Two SCU in 1 cryostat with canting magnets, BPM, Corrector (~1.5m each)	SCU1.65*	SCU1.65*				2
12		CUR	Canted 2.1m long devices - Need Canting magnets, BPM	Planar 2.8*	Planar 2.8*		1	1	2
13	GSECCARS	CUR	Canted 2.1m long devices - Need Canting magnets, BPM	Planar 3.3*	Planar 2.7*		1	1	2
14	BIOCARS	HHL	Two planar devices in tandem (~2.4m each) with a Phase Shifter and corrector	Planar 2.1	Planar 2.1	1	1		
15	CHEMMATCARS	CU	Canted 2.1m long devices - Need Canting magnets, BPM		Planar 2.8*		1	1	2
16	HP	CUR	Canted 2.1m long devices - Need Canting magnets, BPM	Planar 2.7*	Planar 2.5*		1	1	2
17	IMCA	HHL			Planar 3.3				
18	BIO	HHL			Planar 3.3				
19		HHL	Two revolvers in tandem (~2.4m each) with Phase Shifter and corrector	Rev 2.5/2.1	Rev 2.5/2.1	1	1		
20		HHL	Two SCU in 1 cryostat in tandem (~1.75 m each) with Phase Shifter and corrector	SCU1.65	SCU 1.65				
21	LS	CUR	Canted 2.1m long devices - Need Canting magnets, BPM	Planar 3.0*	Planar 2.1*		1	1	2
22	SER	CUR			Planar 3.3*		1	1	2
23	GMCA	CUR	Canted 2.1m long devices - Need Canting magnets, BPM	Planar 3.3*	Planar 3.0*		1	1	2
24	NE	CUR	Canted 2.1m long devices - Need Canting magnets, BPM	Planar 3.0*	Planar 2.1*		1	1	2
25		CU	Canted 2.1m long devices - Need Canting magnets, BPM	Planar 2.8*	Planar 2.8*		1	1	2
26	CNM	HHLR	Two planar devices in tandem (~2.4m each) with a Phase Shifter and corrector	Planar 2.5	Planar 2.5	1	1		
27		HHLR	Two planar devices in tandem (~2.4m each) with a Phase Shifter and corrector	Planar 2.7	Planar 2.7	1	1		
28		CU	Two SCU in 1 cryostat with canting magnets, BPM, Corrector (~1.2m each)	SCU1.85*	SCU1.85*				2
29		HHLR	Full 4.8m existing IEX device	IEX	IEX				
30		HHLR	Two planar devices in tandem (~2.4m each) with a Phase Shifter and corrector	Planar 1.35	Planar 1.35	1	1		
31	LILY/SBC	CU	Canted 2.1m long devices - Need Canting magnets, BPM	Planar 3.3*	Planar 3.3*		1	1	2
32		CU	Canted 2.1m long devices - Need Canting magnets, BPM	Planar 1.35*	Planar 2.8*		1	1	2
33		HHL	Two revolvers in tandem (~2.4m each) with Phase Shifter and corrector	Rev 2.5/2.1	Rev 2.5/2.1	1	1		
34		CUR	Canted 2.1m long devices 1 Rev, 1 Planar- Need Canting magnets, BPM	Planar 2.8*	Rev 2.5*/2.1*		1	1	2
35	DCS	HHLR			Rev 2.3/1.35				
Tally:				22(3)	29(6)	10	24	14	32

* Indicates canted location – ID length will be 2.1 m for planar IDs and <1.5 m for SCUs.

Two devices in tandem will require 1 phase shifter and 1 corrector in the middle

Canted devices will require two half-strength canting magnets (upstream and downstream), 1 center canting magnet and 1 corrector

51 Gap Separation Mechanisms (GSMs); (9 will be used with revolver magnets)

Total 60 HPMU magnet structures (40 new; reuse 20)

10 locations will use phase shifter + corrector combinations

14 locations will use upstream, downstream, center canting magnets and a corrector magnet

2 additional sectors with SCUs will also use upstream and downstream canting magnets

Current APS Insertion Devices – Status March 2018

- A variety of periods installed and operational (a total of 54 magnet structures)
- Minimum magnetic gap of most HPMUs is 11.0 mm. The gap is fixed at 9.5 mm for the planar SCUs.

Type†	Period (cm)	Number of Units
Planar	3.3	29
Planar	3.0	8
Planar	2.7	4
Planar	2.3	2
Planar*	1.8	1
Planar	1.72	3
Planar (SmCo)	3.5	1
Planar	3.6	1
Planar#	5.5	0
EMVPU	12.5	1
CPU	12.8	1
SCU (NbTi)#	1.6	0
SCU (NbTi)	1.8	2
h-SCU (NbTi)+	3.15	1

†NdFeB magnets

#Device removed since 2016

*,+ Planar HPMU 1.8 cm and helical SCU

3.15 cm periods devices not shown in

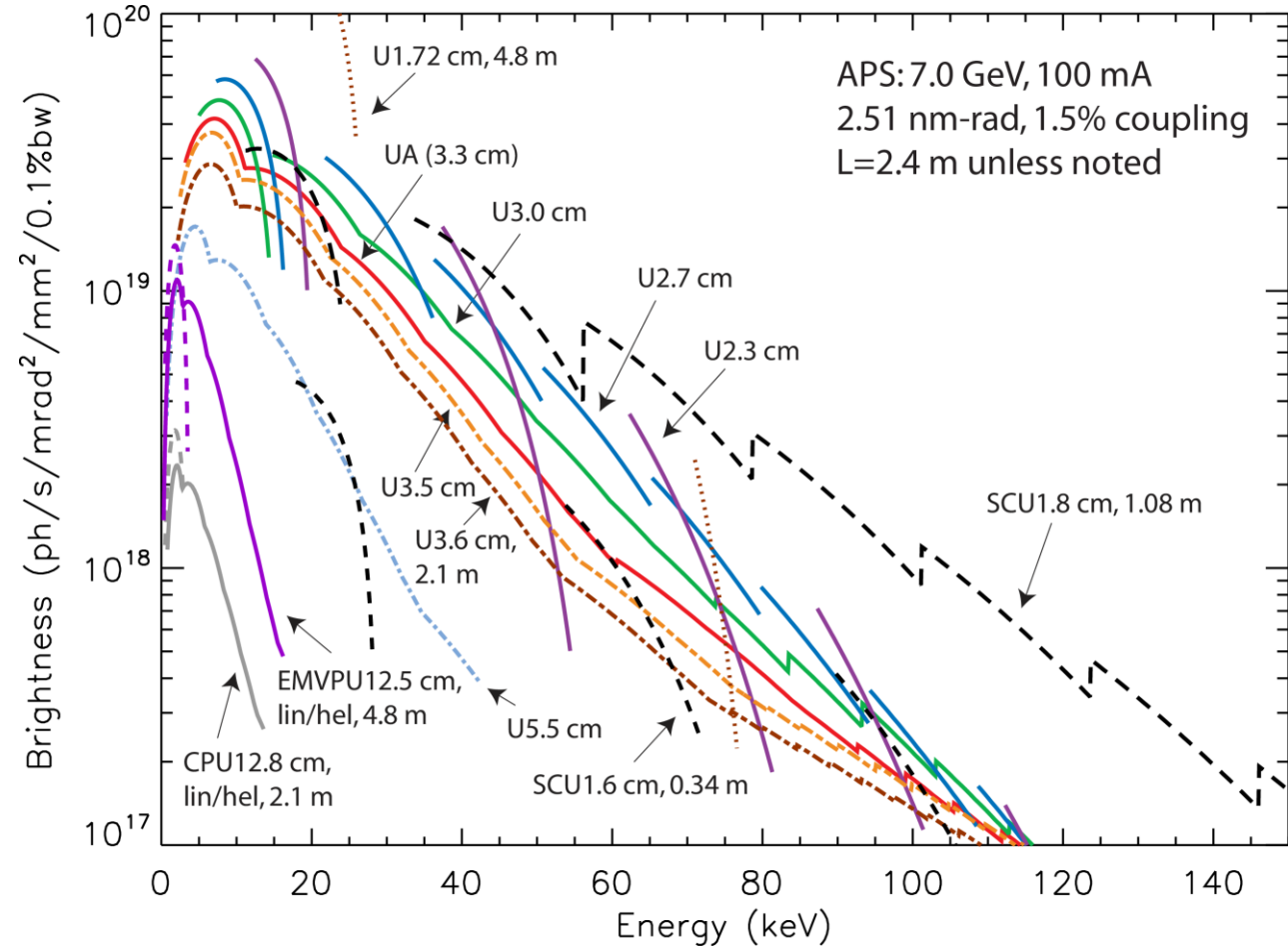

APS brightness of odd harmonics of operational HPMUs (2.4 m) and planar SCUs

APS-U Insertion Devices

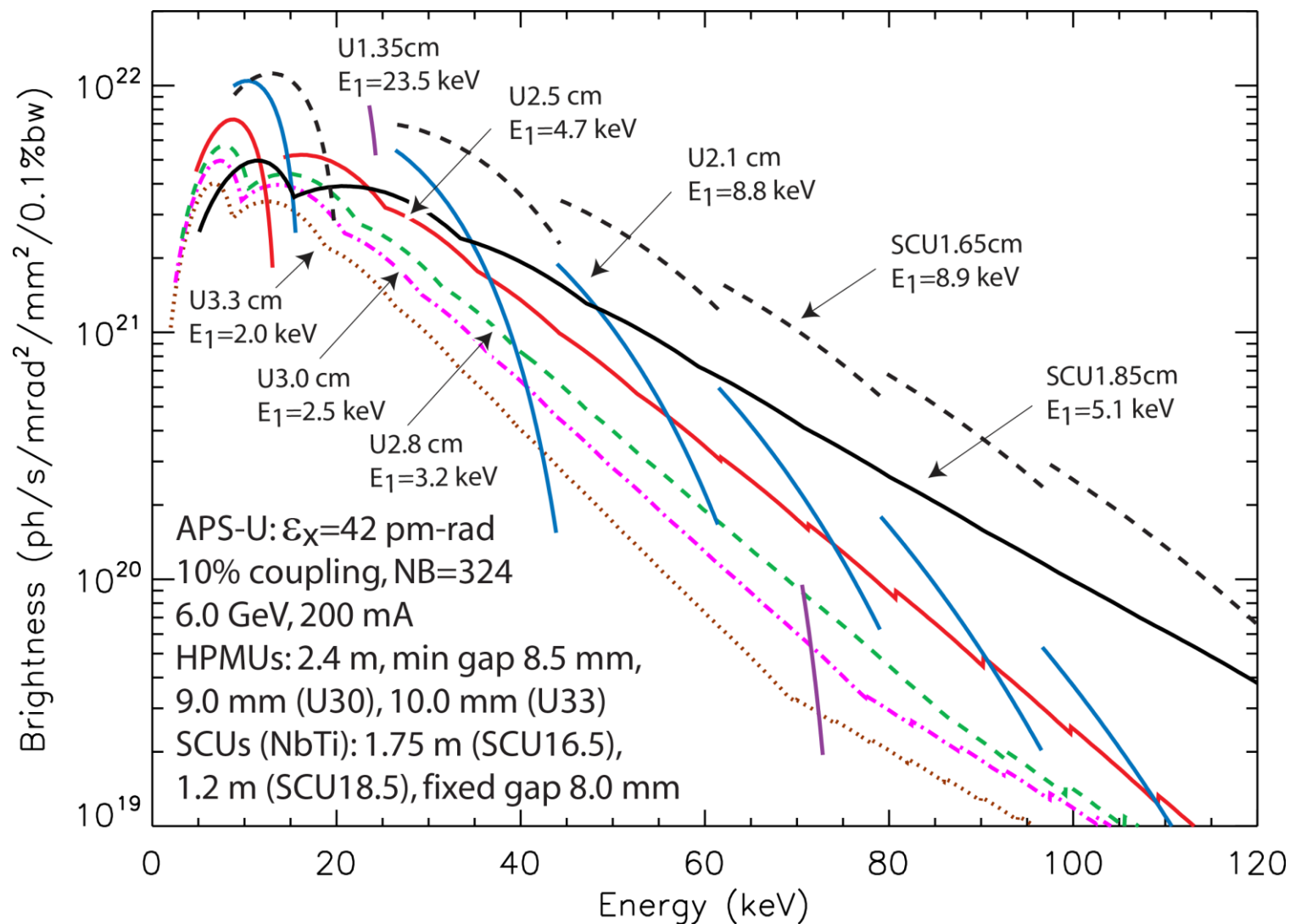

Calculated brightness tuning curves of odd harmonics of most HPMUs and SCUs for APS-U. The U28 (dashed green curve) provides continuous energy coverage above 3.2 keV. (Overlaps have been removed for clarity.)

ID General Requirements

- User requirements
 - High brightness of high harmonics -> small phase errors (use RMS phase error as metric)
 - Expanded continuous photon energy coverage -> short-period undulators in revolvers
 - Operational reliability -> keep demagnetization of permanent magnets to minimum (choose magnet grade with large intrinsic coercivity and keep electron beam stable)
 - Photon beam reproducibility and stability -> sound magnetic and mechanical ID design and electron beam corrections
- Storage ring requirements
 - Tune for small first and second field integrals (expressed in entrance and exit trajectory angles for orbit stability), integrated multipole errors (lifetime, injection efficiency, ...)

ID Requirements/Interfaces

- Space allocated for IDs/IDVCs, inclusive of the RF BPM/bellows assemblies, is unchanged from the current APS straight sections (valve-to-valve). Due to shorter aperture transitions (in the IDVC) and shorter BPMs the space available for planar HPMUs increases slightly (from 4910 mm to **~5050 mm**).
- All IDs/IDVCs must meet the storage ring physics and x-ray quality requirements – [documented in ID FReD](#)
- IDs have safety interfaces to the storage ring and front ends – [documented in HPMU ICD](#)
- ID parameters (period, planar vs. elliptical, etc.) are specified in [front end/ID beamline ICDs](#)

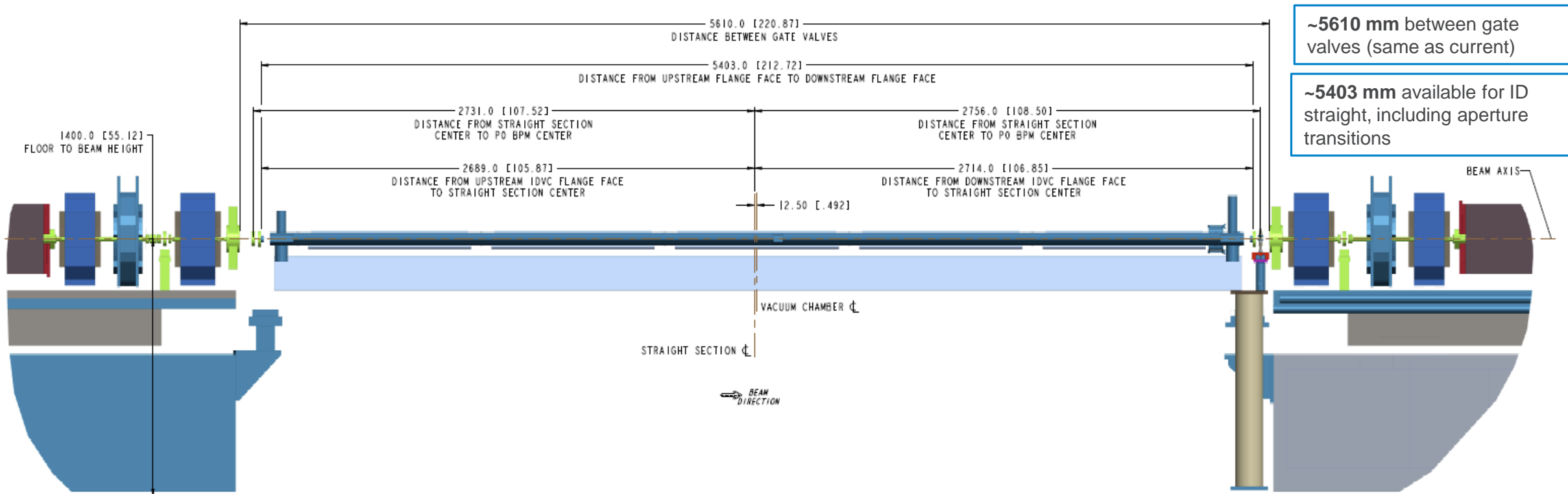

ID Specifications for Planar HPMUs (from ID FReD)

ID Global Specifications

Parameter	Value	Unit
Number of ID straights	35	
Insertion device maximum length	4.8	m
Vertical magnetic gap	≥ 8.5	mm
ID chamber vertical aperture	≥ 6.3	mm
Maximum canting angle	1	<u>mrad</u>
Vacuum chamber straightness in plane with small magnetic gap	50	μm
ID <u>rms</u> phase error for any operational gap ¹⁾	~ 3	degree

1) Target value for all IDs.

May be relaxed for select IDs not operating at high harmonic energies.

ID Drive System Specifications

Parameter	Value	Unit
Minimum gap (normal operation)	8.5	mm
Minimum gap (absolute operational limit)	8.2	mm
Gap taper (maximum)	5.0	mm
Maximum gap	125 - 180	mm
Gap resolution	0.5	μm
Gap repeatability (unidirectional)	< 3	μm
Gap stability	< 5	μm
Rate of gap change	1	mm/s

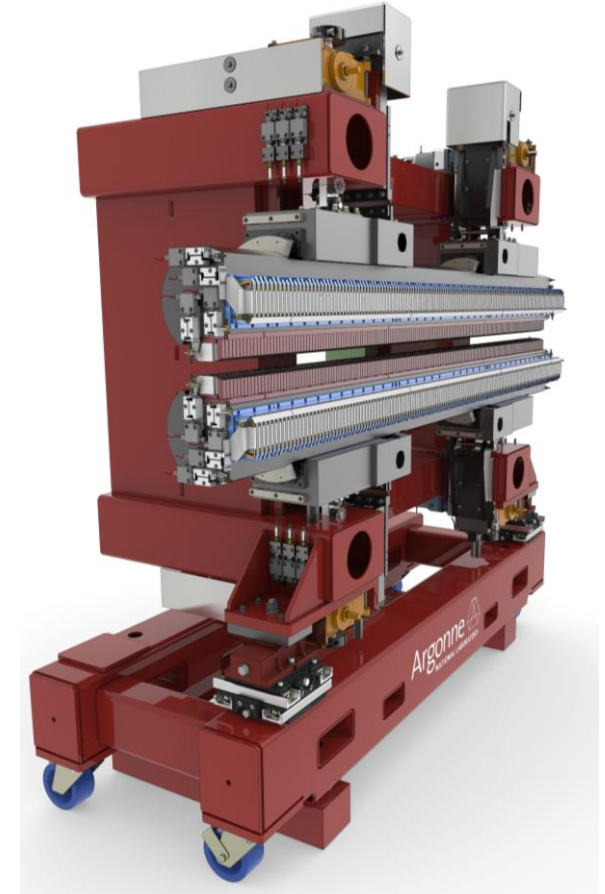

Selection of Period Lengths

- For high brightness make period length as short as possible subject to heat load and engineering and physics constraints
- Generally shorter periods will be required for same energy coverage (beam energy 7 GeV \rightarrow 6 GeV). For the HPMUs most commonly requested periods are 2.1 – 2.8 cm and for the SCUs (NbTi) 1.65 and 1.85 cm.
- Magnetic gaps reduced from \sim 10.5 mm to 8.5 mm (HPMUs) and from 9.5 mm to 8.0 mm (SCUs)

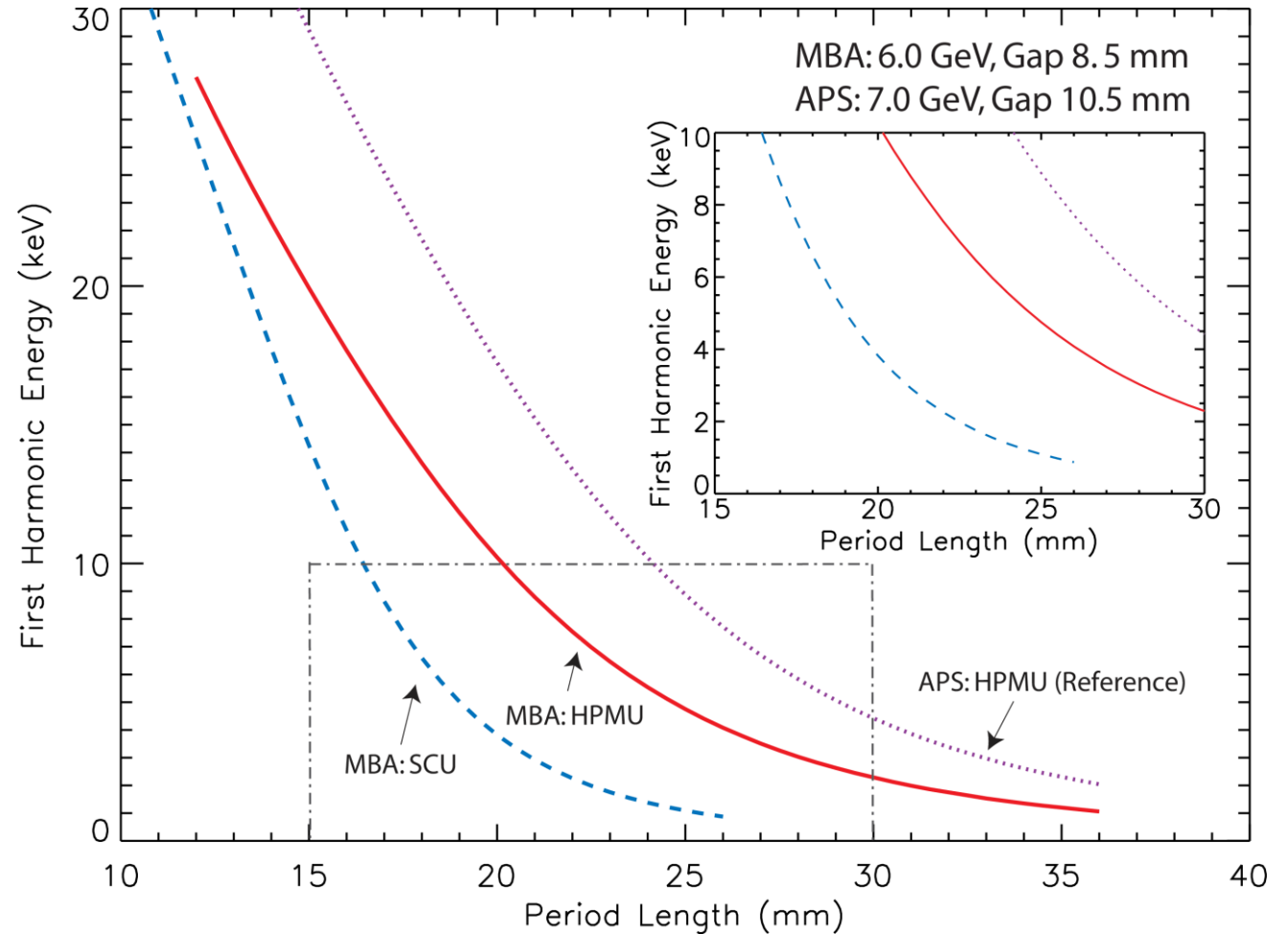

First harmonic energy of HPMUs and SCUs at 6 GeV (8.5 mm magnetic gap) compared to 7 GeV (10.5 mm magnetic gap)

Beamline Interface Control Documents (ICDs)

- Documents approved and signed by beamline staff and APS-U management
- Resides in the Information Content Management System (ICMS) including approval threads
- Identifies ID parameters (type, min gap, length, fundamental energy, powers) and shows spectra and type of front end required



APS-U 24-ID Beamline to Front End and Insertion Devices Interface Control Document

APS-U Document #: APSU-2.05.01-ICD-024	WBS Number: U2.05.01	Revision: 0	ICMS Content ID: APSU 190952
--	--------------------------------	-----------------------	--

This printed or electronic version of the document may not be the current or approved revision. The current revision is maintained in the Advanced Photon Source Upgrade (APS-U) Project's Integrated Content Management System (ICMS) where all internal Project document approvals are managed. ICMS can be accessed through the web by authorized users, <https://icmsdocs.aps.anl.gov/>, and this document can be identified by the document and version number as indicated in the Version Control Table below. Note that the revision number in the table below and in ICMS may not match. The current approved version is always available in ICMS.

Approvals for this document will be required from:

Steven E. Ealick, NE CAT Director
Malcolm Capel, NE CAT Deputy Director
Dennis Mills, PSC Deputy Associate Laboratory Director
Yifei Jaski, APS-U/ CAM Front Ends
Roger Dejus, APS-U/CAM Insertion Devices
Dean Haeffner, APS-U/APM Experimental Systems
Mohan Ramanathan, APS-U/APM Front End and Insertion Devices
Tom Fornek, APS-U/APM Integration and Coordination

Beamline Interface Control Documents (ICDs) – Sector 23-ID

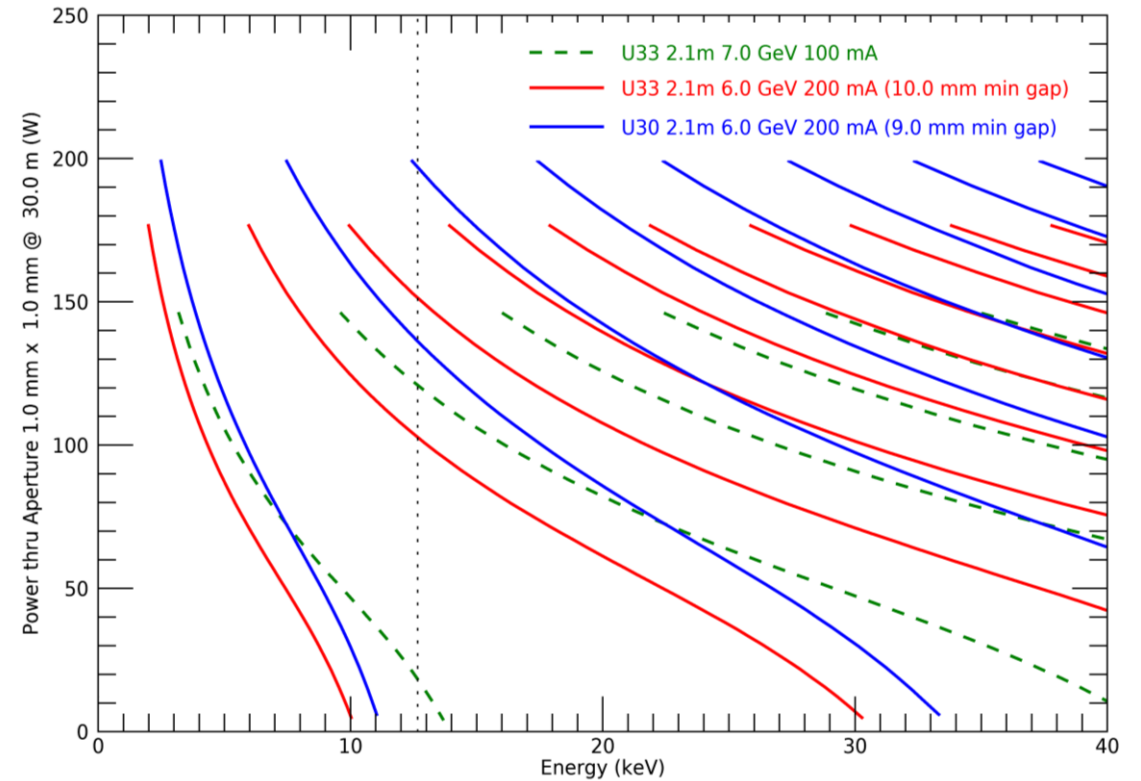
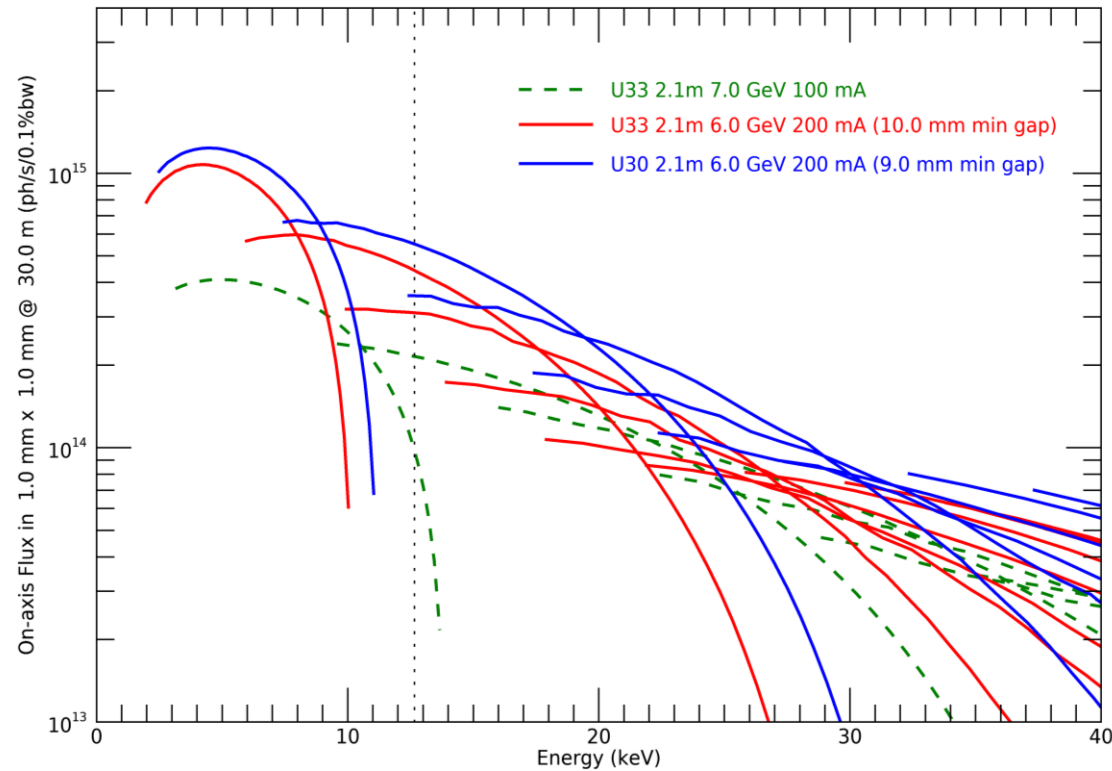

Left: Calculated on-axis flux tuning curves at 30 m of odd harmonics of the U33 and U30 undulators. Right: Aperture power of the same. The reference line marks the energy of the Se K-edge (12.658 keV).

The reused U33 and U30 undulators were selected (instead of shorter-period undulators) to limit the power at the Se K-edge

Beamline Interface Control Documents (ICDs) – Sector 8-ID

- The U28 undulator is fully tunable above 3.2 keV (green dashed curve)
- The revolver undulator U25/21 is optimized for high brightness for 5 – 15 keV “sweet spot”
- The revolver undulator U25/U21 provides full tunability from ~5 keV

The combination of the 2.5/2.1 cm periods is sufficient and the 3-headed revolver initially considered for the APS-U was removed

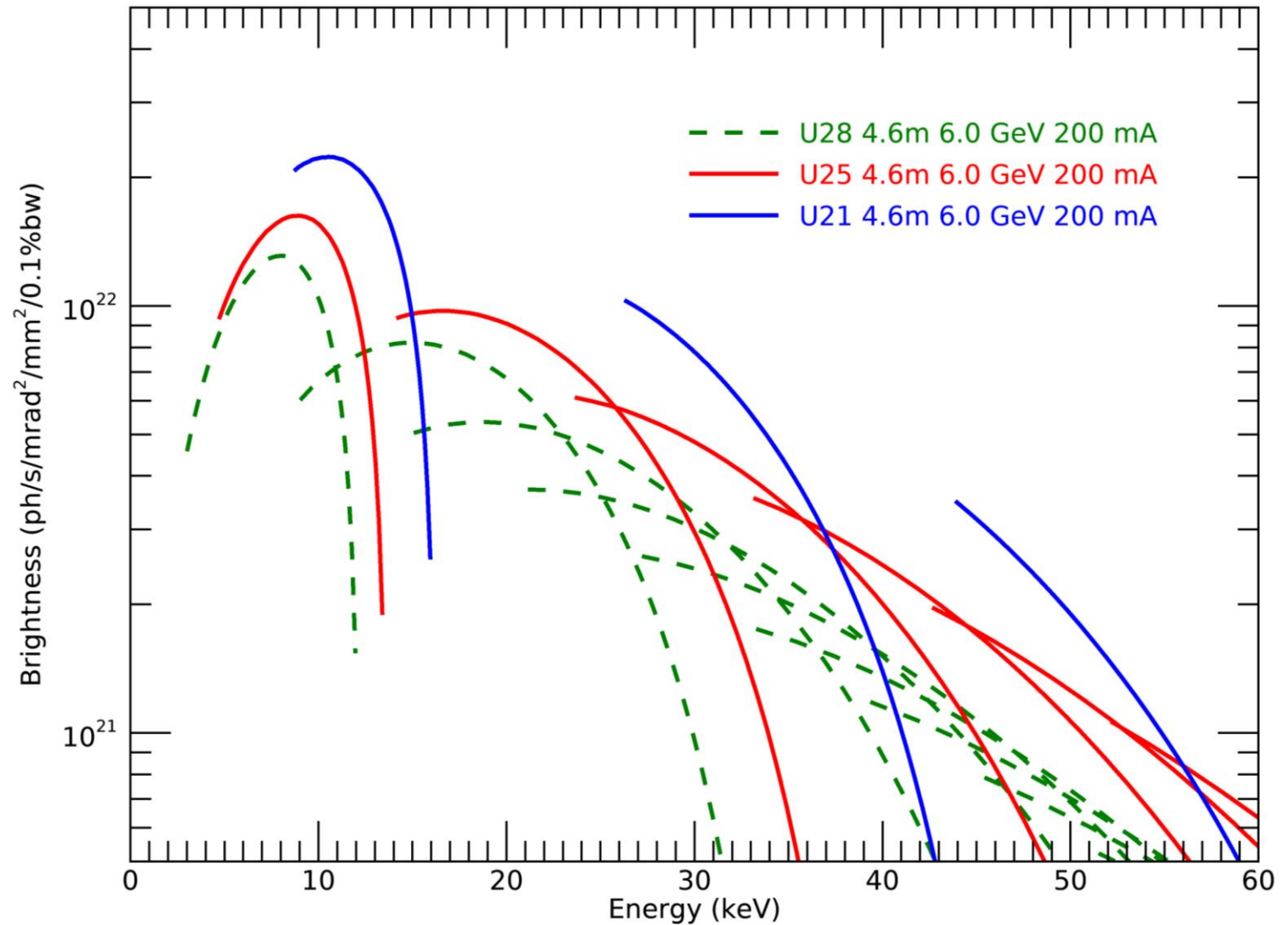

Calculated brightness tuning curves of odd harmonics of the U28 undulator compared to the revolver undulator U25/21 at a magnetic gap of 8.5 mm

Hybrid Permanent Magnet Undulators (HPMUs)

- Each HPMU consists of
 - Magnets
 - Poles
 - Monokeeper and strongback
 - Gap Separation Mechanism (GSM)
- The GSM is common to all period lengths and is used for both planar and revolver IDs
- We have exactly 49 GSMs (counting different types)
 - To mitigate risk of delays in assembly and tuning 4 new GSM are procured
- 20 existing ID's magnets and pole pieces will be reused with new monokeepers
- Undulators designed and built by the APS have recently been tuned to APS-U requirements to benchmark mechanical design and to identify areas for improvement for high volume production

New strongback

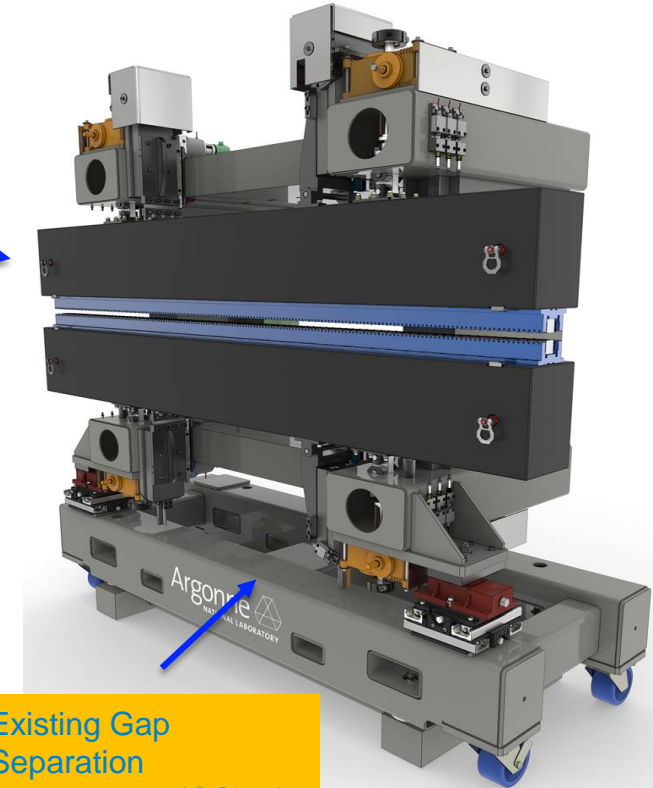

Existing Gap Separation Mechanisms (GSMs)

New Monokeeper

Magnet and poles

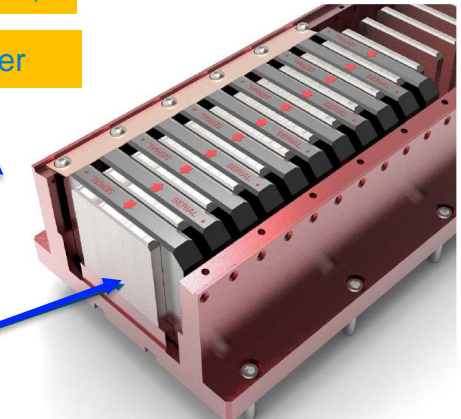

Phase Errors – HPMUs

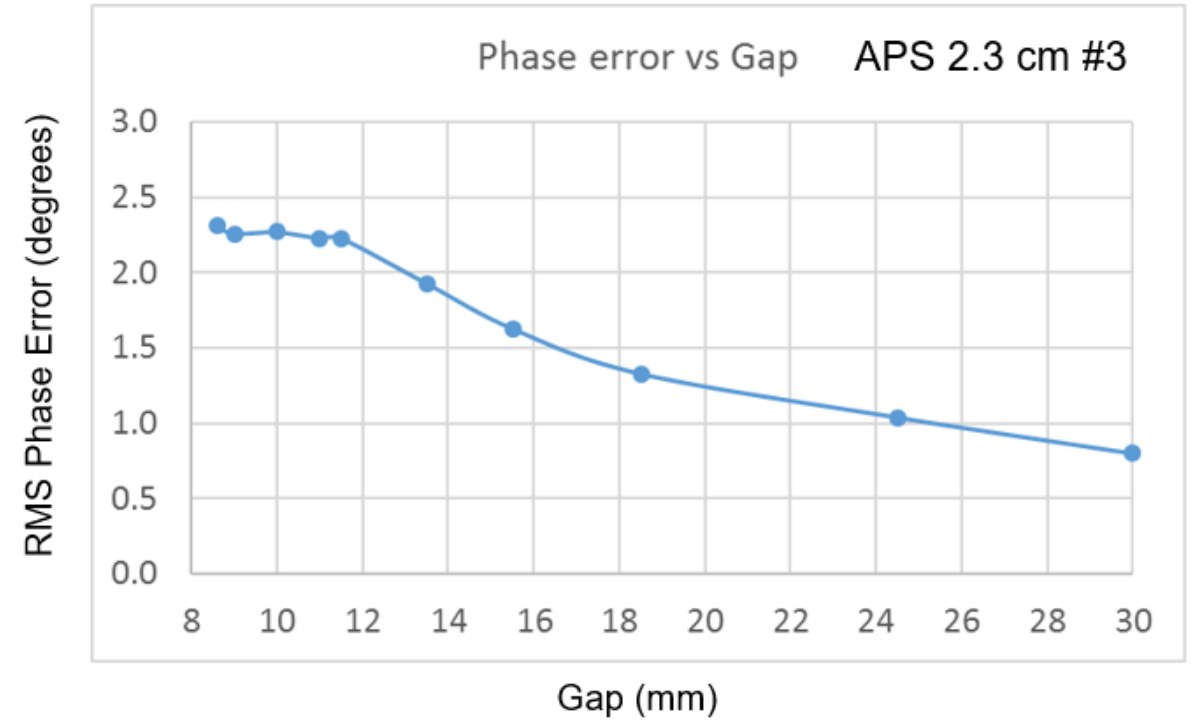
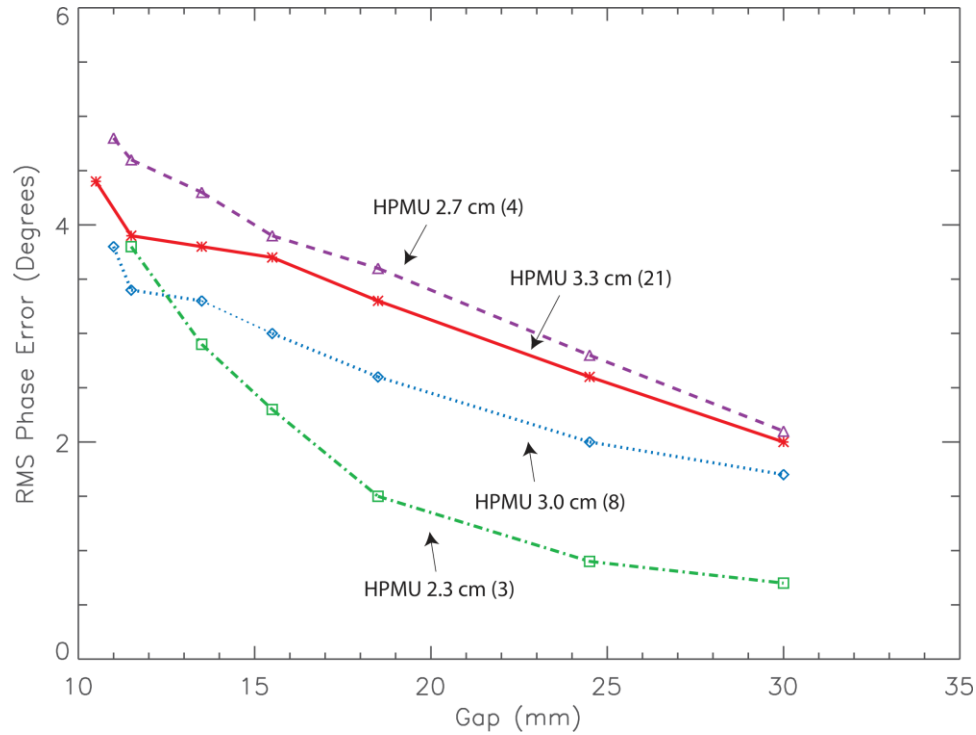

Measured averaged RMS phase errors of current APS planar undulators. The number of devices used in the analyses in parenthesis.

Retuned APS legacy undulator down to 8.2 mm magnetic gap

- Small phase errors => high brightness for high harmonics
- Typically less than 5 degrees RMS (min gap 10.5 mm; APS-U 8.5 mm => more challenging)

Planar HPMUs Magnetic Design

- A study was completed using OPERA-3D to optimize magnet and pole sizes and shapes for a smaller transverse “good field” region than for current APS undulators (± 5 mm \rightarrow ± 3.0 mm)
- A period length of 2.8 cm was selected for the first new set of undulators (“new” Undulator A) because it provides a continuous energy tuning range for a magnetic gap of 8.5 mm
- The design maintains field strength with smaller magnets and poles and with smaller magnetic forces \rightarrow gap dependent deflections smaller \rightarrow magnetic tuning faster to meet requirements
- ID vacuum chamber development now allows a minimum gap of ~ 8.4 mm using current safeguards; period selection in ICDs used 8.5 mm gap to define minimum x-ray energy

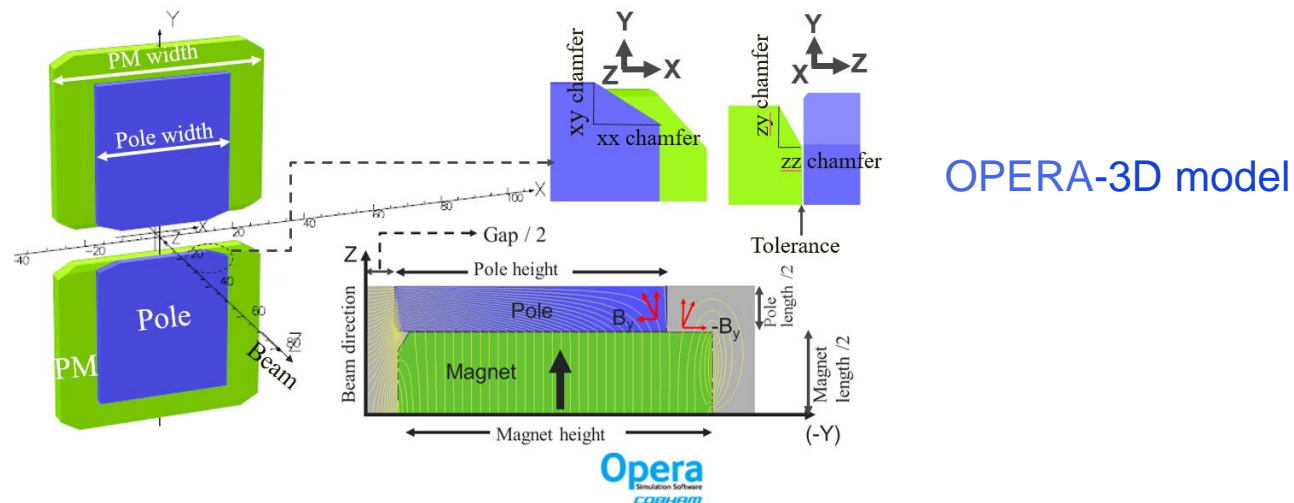

Phase Shifters and Canting Magnets

- Inline IDs (10 locations)
 - Each needs a permanent magnet (PM) phase shifter
 - A H-V corrector magnet in the middle
 - Each corrector requires 2 power supplies
- IDs in canted geometry (15 locations including 2 SCU based)
 - Each requires a 0.5 mrad dipole magnet (canting magnet) at the upstream and downstream locations
 - A 1 mrad dipole magnet in the middle
 - A H-V corrector magnet in the middle
 - Each location requires 3 power supplies

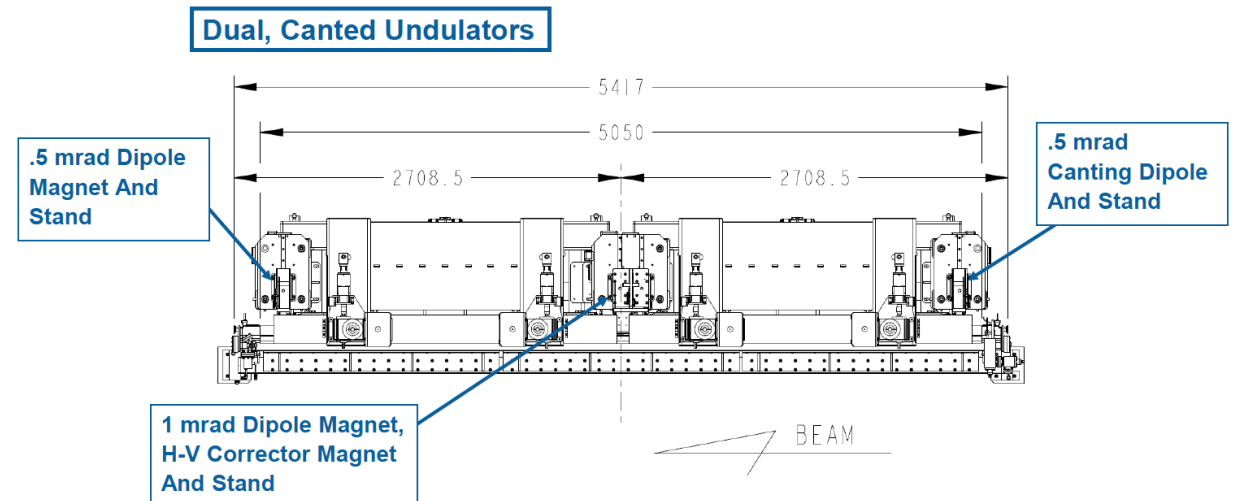
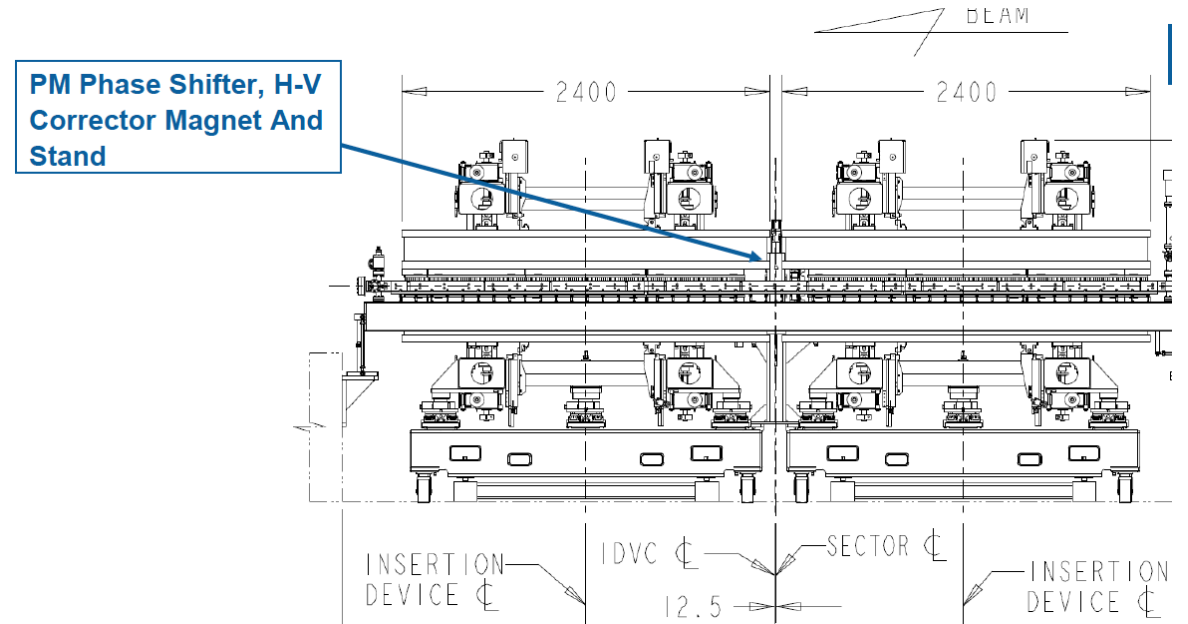

Phase Shifters Magnetic Design

Magnetic fields for different gaps

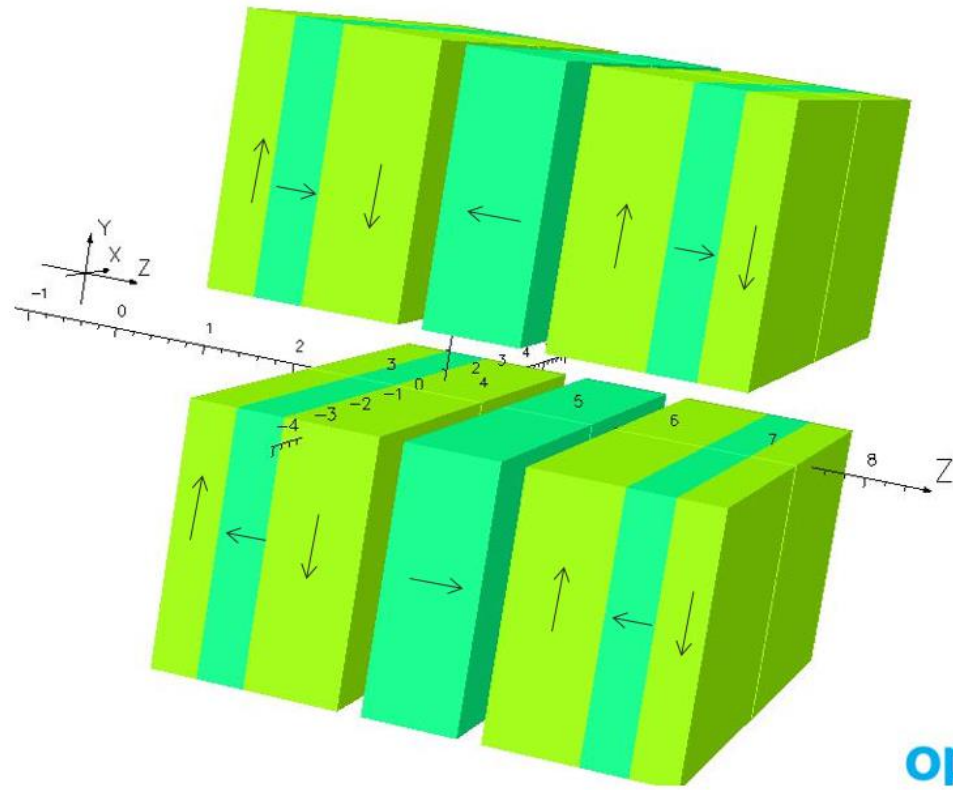

op

- Based on the LCLS-II HXR design done at the APS

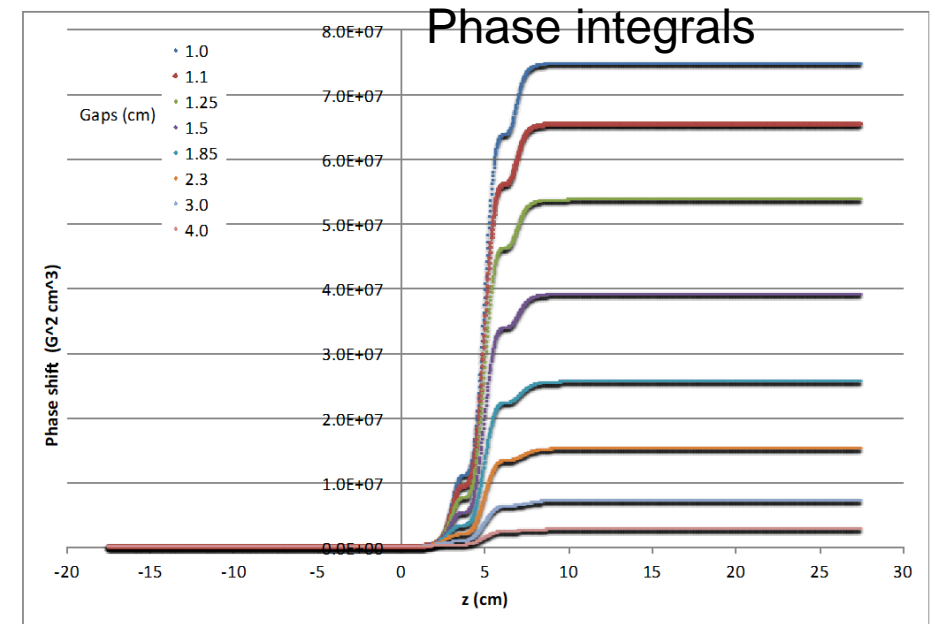
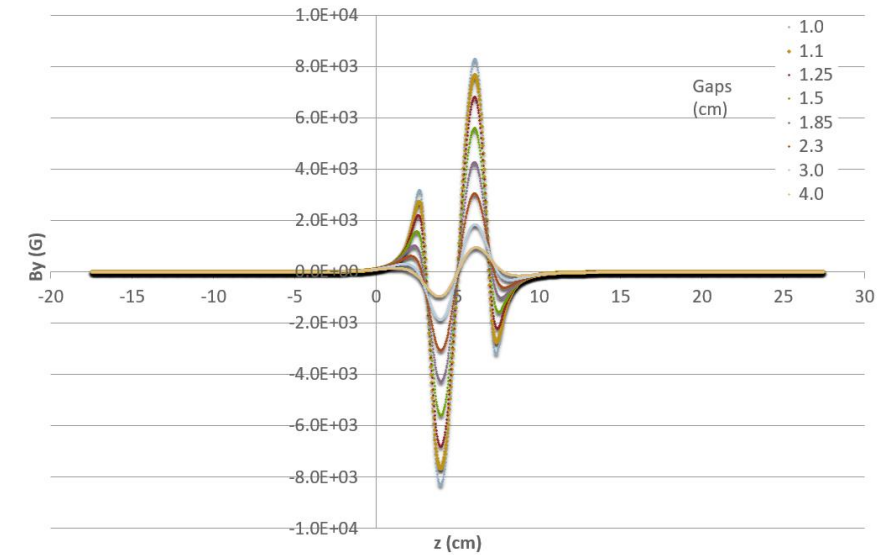

Planar SCU Magnets

- Magnet design is based on successful experience of building four planar SCUs
 - Period lengths: 16 mm, 18 mm, 21 mm
 - Achieved magnet length: 1.5-m magnet for LCLS R&D
 - Achieved phase error of 3° rms for second 1.1-m long magnet
- Challenges (addressed in the R&D phase)
 - Keeping magnetic gap within $50\ \mu\text{m}$ and tolerances within $25\ \mu\text{m}$ over 1.8-m-long magnets
 - Fabrication of 4.4-m-long thin-wall (0.4 mm) vacuum chamber
 - Magnetic measurements in long cryostat



Assembled 1.1-m long SCU magnet

See upcoming
ASD seminars
by M. Kasa and
Y. Shiroyanagi

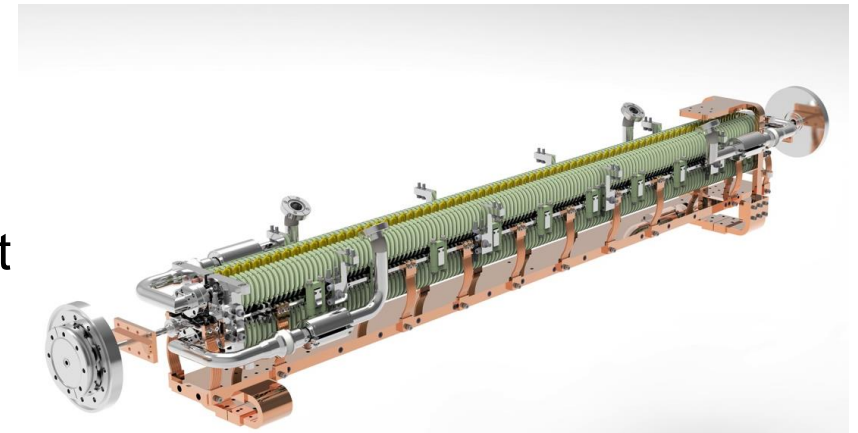

Design model of assembled planar SCU magnet

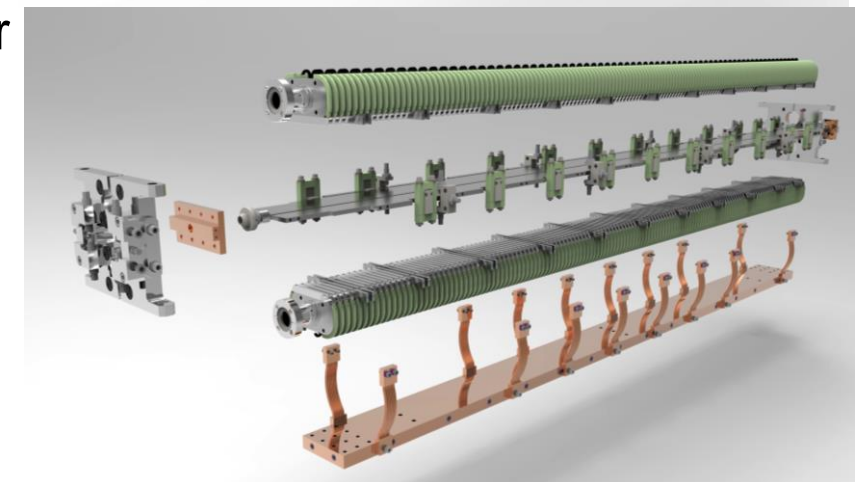

Exploded view of planar SCU design model with vacuum chamber

SCU Cryostats

- Cryostat evolution from second generation developed for APS helical SCU
 - Extend packaging and cold mass support techniques to longer device length (~4.5-m-long cryostat accommodates 2 magnet structures of either planar or SCAPE type)
 - One thermal shield
 - Four RDK415D cryocoolers
 - Two temperature stages
 - Reduced diameter of the vacuum vessel
 - Vertical turrets
 - Standard flanges for the end covers
 - Simplified design of He filling port

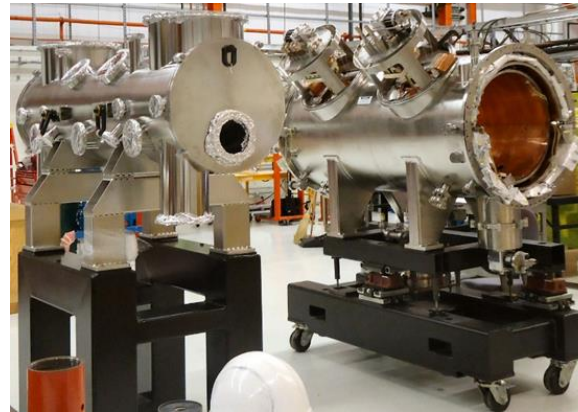

Left: Second generation cryostat for helical SCU
Right: First generation for current SCUs

See upcoming ASD seminar
by J. Fuerst for details

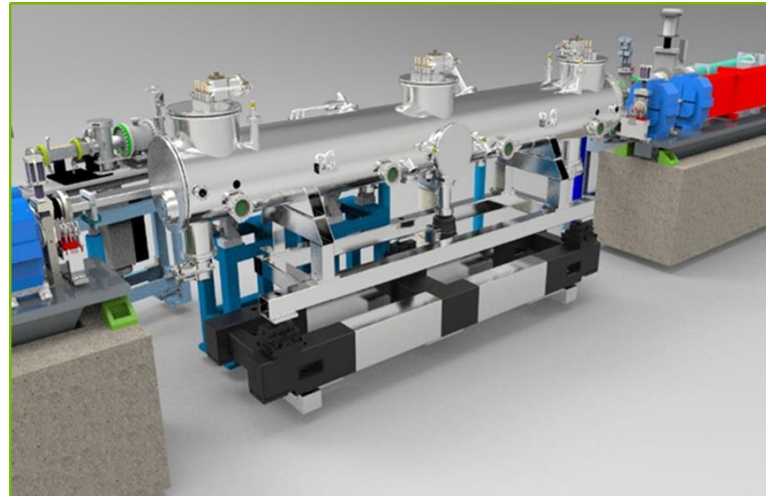

Design model of APS-U SCU cryostat in ID straight section

HPMU & SCU IDVCs

- Evolution of HPMU IDVC design from current APS (2016) to review February 2017 and to final design review May 2018
- Demonstrated feasibility of RAM EDM fabrication of aperture transition (integrated end box design)
- Applying lessons from the HPMU IDVC development to the planar SCU IDVC development

APS design 2016

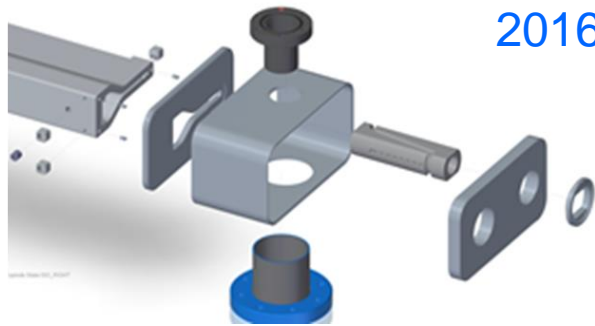

2016

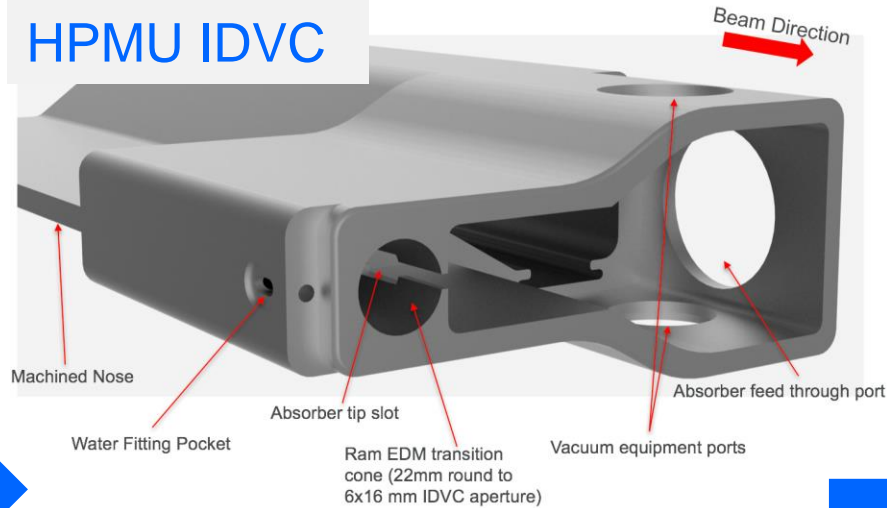

2017

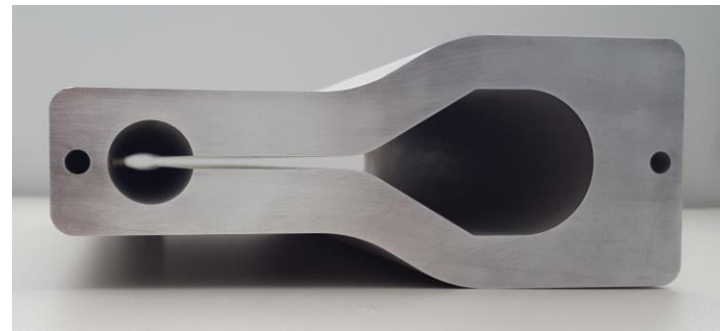

Short prototype for testing RAM EDM feasibility (2017)

SCU IDVC

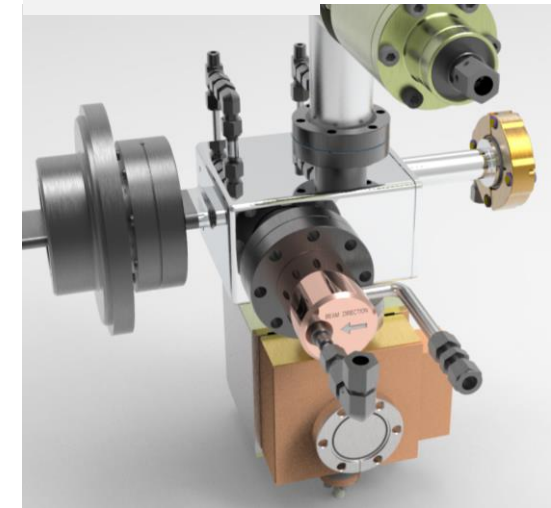

Assembly view of planar SCU IDVC with transition end box



SCU IDVC Machined Cross Section

HPMU Challenges – Assembly and Magnetic Tuning

Planar ID Type	Existing	New	Total
APSU33 (2.4 m)	4		4
APSU33 (2.1 m)	5		5
APSU30 (2.4 m)	2		2
APSU30 (2.1 m)	3		3
APS28 (2.4 m)		1	1
APS28 (2.1 m)		9	9
APS27 (2.4 m)	2		2
APS27 (2.1 m)	3		3
APS25 (2.4 m)		11	11
APS25 (2.1 m)		2	2
APS23 (2.4 m)	1		1
APS21 (2.4 m)		10	10
APS21 (2.1 m)		3	3
APS13.5 (2.4 m)		3	3
APS13.5 (2.1 m)		1	1
Total	20	40	60

- Assembly and magnetic tuning of 60 magnet structures
 - The magnets, pole pieces, magnet keepers, and strongback are designed in-house and will be assembled in-house (or by vendors)
 - All magnetic structures (on strongbacks) will be
 - measured and pre-tuned using spare (plus 4 new) GSMs and 2 existing magnetic measurement benches in MM1
 - fine tuned and mated to GSMs “harvested” from the storage ring during the beginning of the shutdown
 - Canting magnets (14 sets; 1 revolver) and phase shifters (10 units; 4 revolvers)
 - Pre-tuning in ~3 years (~3 weeks/structure)
 - Final tuning in ~1 year (~1 week/structure)

Long Lead Procurements (LLPs)

- Long Lead Procurements (LLPs)
 - 10 sets of magnets, poles, and monokeepers (with strongbacks for canted IDs) for 2.8-cm-period IDs
 - Magnet contract awarded September 2018
 - Poles awaiting award September 2018
 - Mechanical components (award expected early FY19)
 - 13 sets of magnets, poles, and monokeepers (with strongbacks for canted IDs) for 2.5/2.1-cm-period IDs in FY19
 - IDVC components
 - Build a full-length 5-m-long ID vacuum chamber prototype with integrated end box and support system

Reduces installation schedule risk

Magnet and poles

New monokeeper

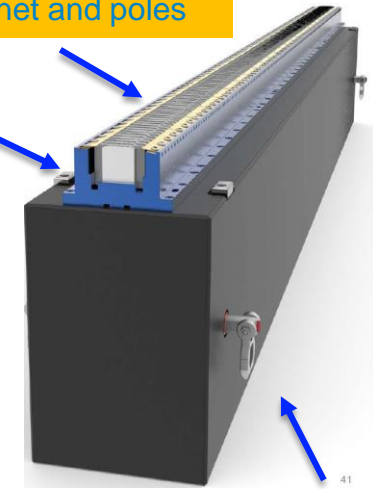

New strongback

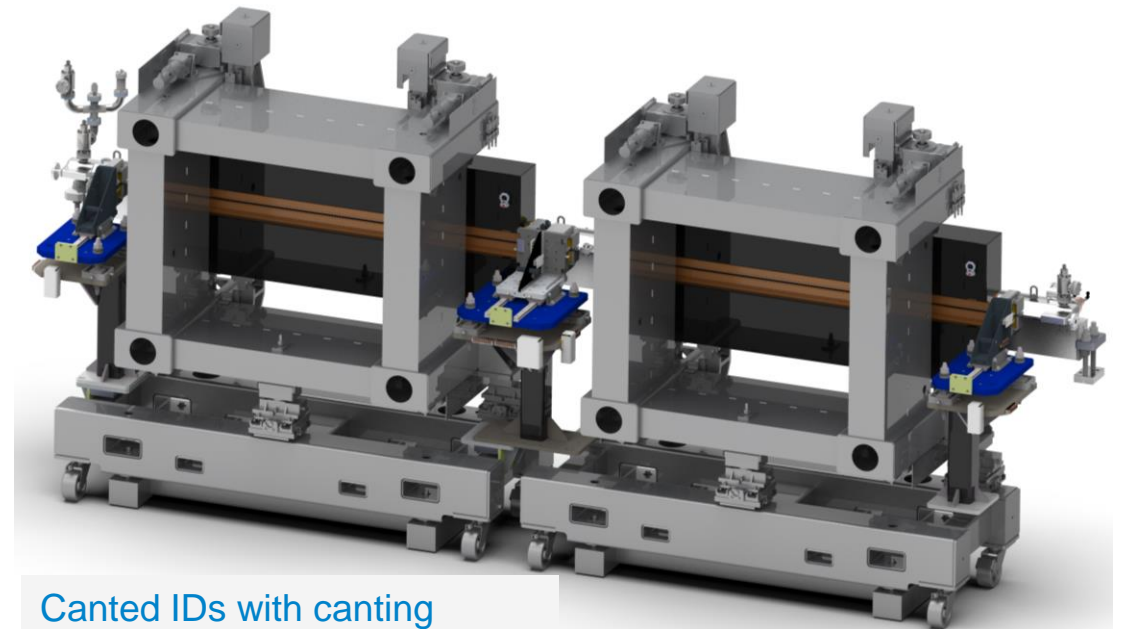

Canted IDs with canting magnets and corrector

Summary

- All ID sources have been identified (beamline users ICDs approved)
- Final design completed for HPMUs (2.8 cm period) and IDVC chamber and supports
- SCU technical challenges addressed in R&D activities
- Long Lead Procurement executed for magnets, poles, monokeepers, and strongback, and IDVC components to reduce installation schedule risk
- We are ready for CD-2 on October 10, 2018 and path towards CD-3 is solid

Thank You

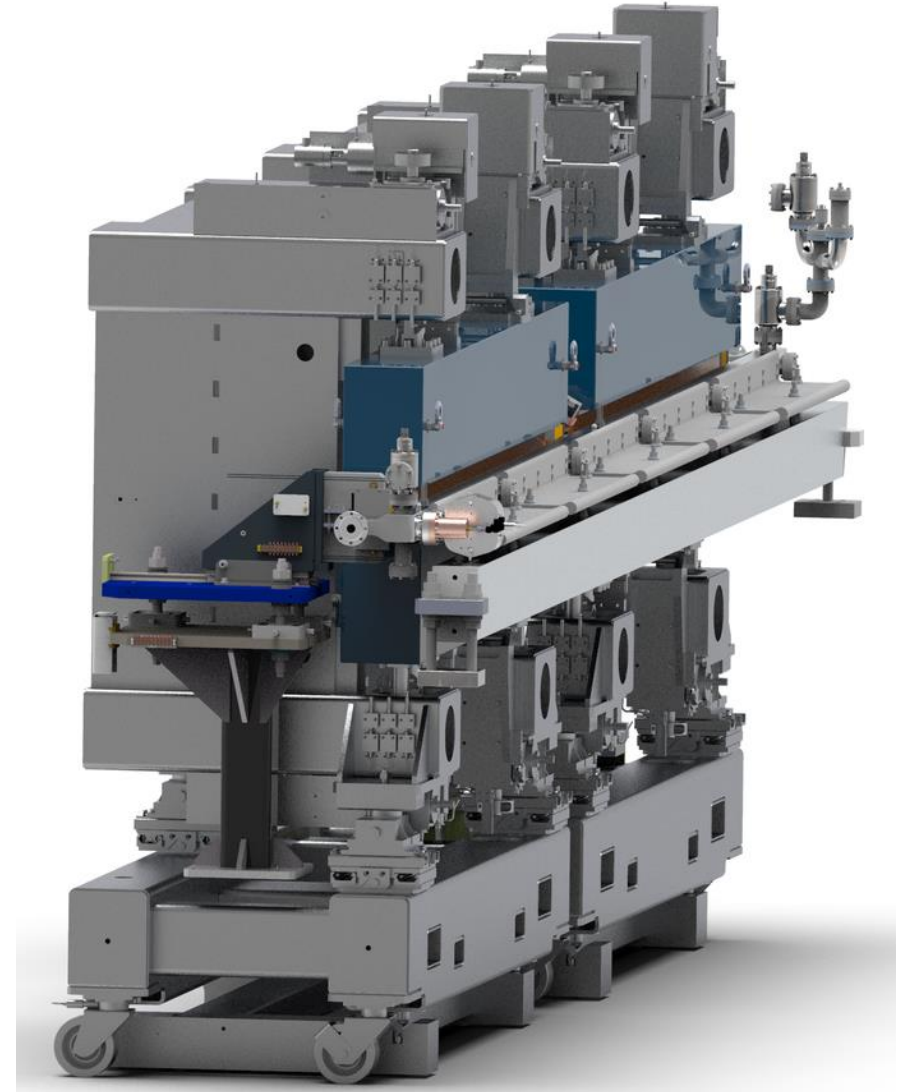

Extra

Total Power Limits

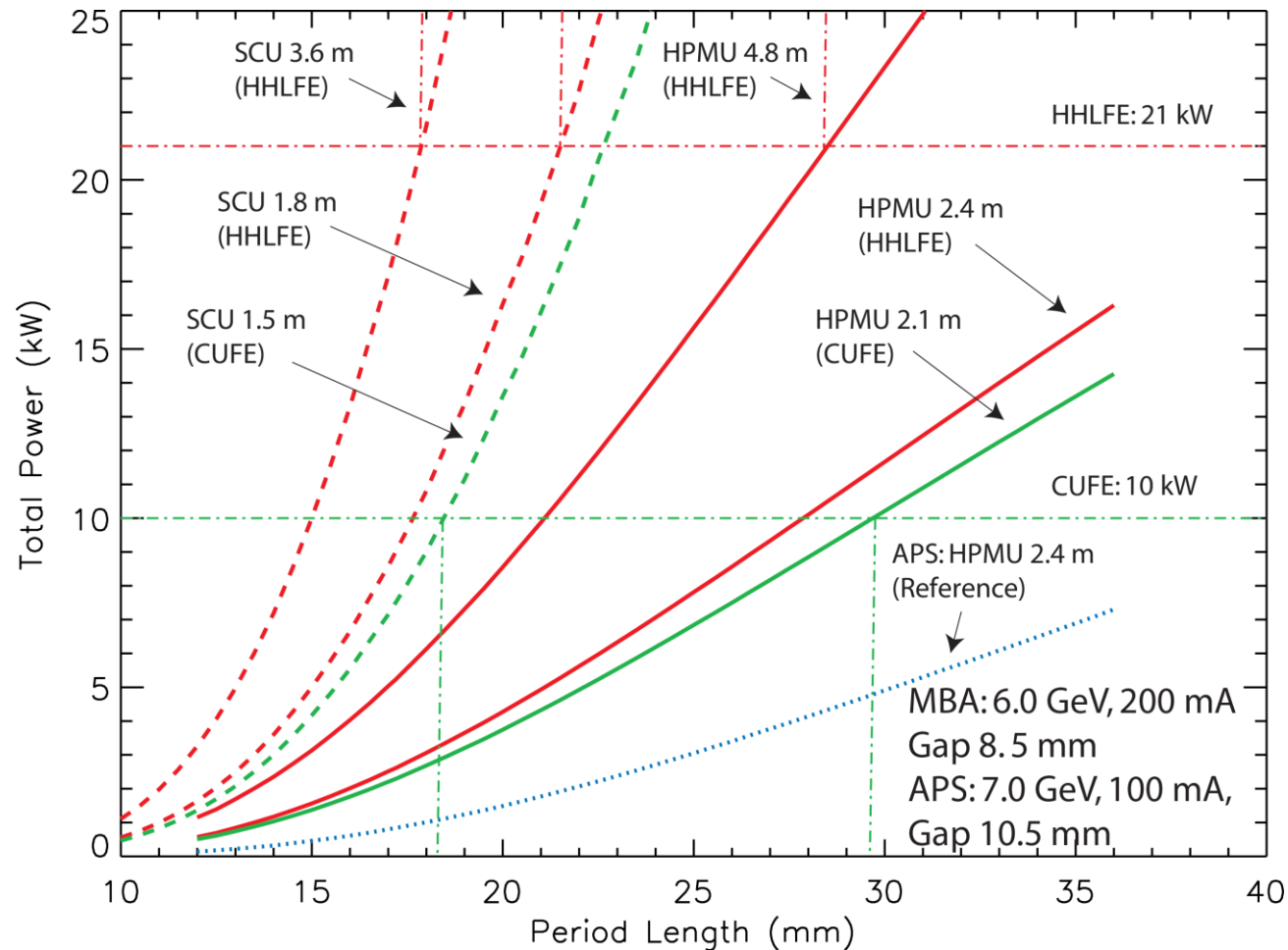

Total power vs. period length for HPMUs and SCUs at 6 GeV and 8.5 mm magnetic gap (limits indicated by horizontal dashed lines)

- For the APS-U all 35 ID front ends will be either High Heat Load Front Ends (HHLFE) or Canted Undulator (CUFE)

On-Axis Power Density Limits

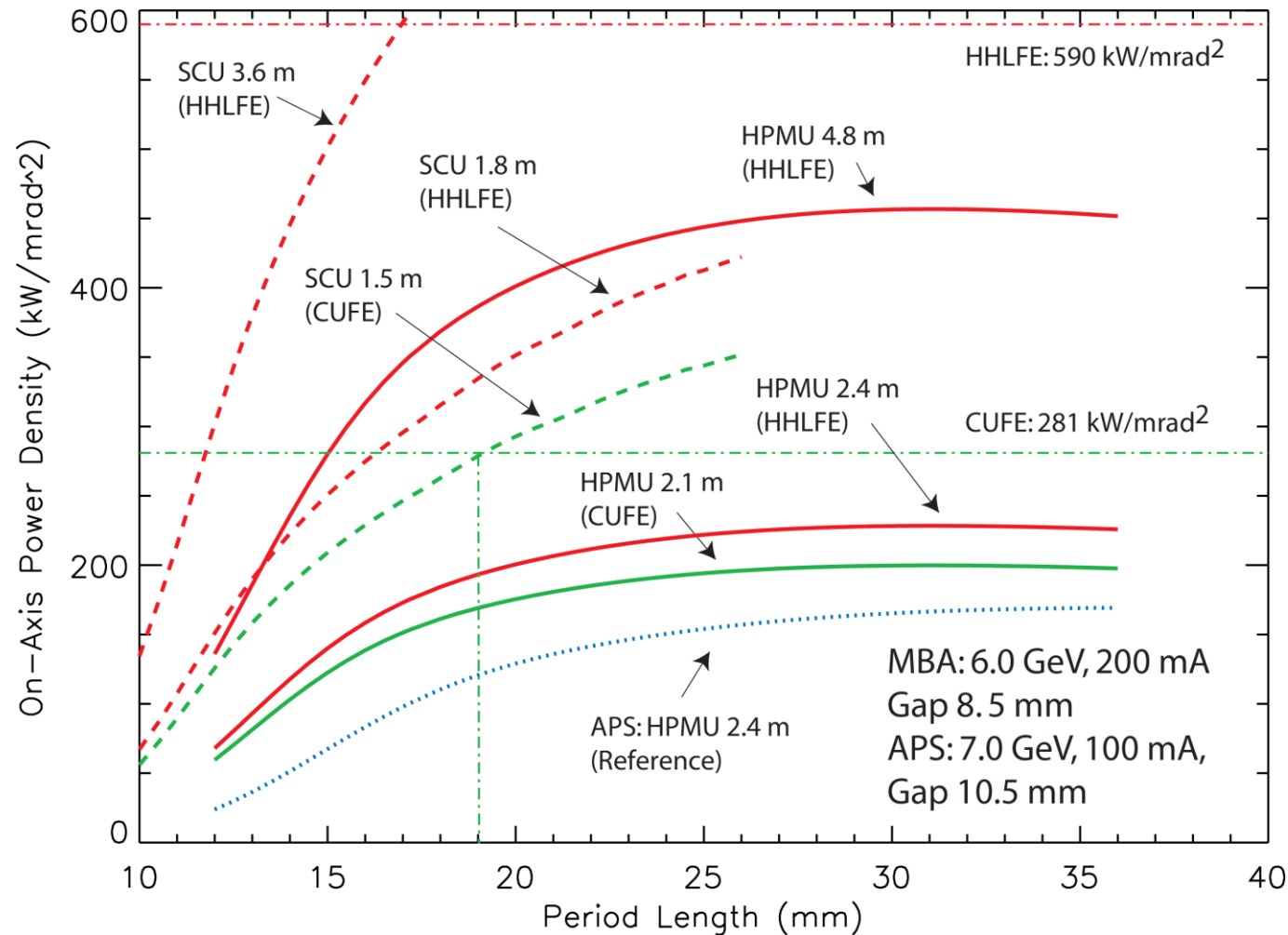

On-axis power density vs. period length for HPMUs and SCUs at 6 GeV and 8.5 mm magnetic gap (limits indicated by horizontal dashed lines)

APS-U User Needs (Energy Scans and Repeatability)

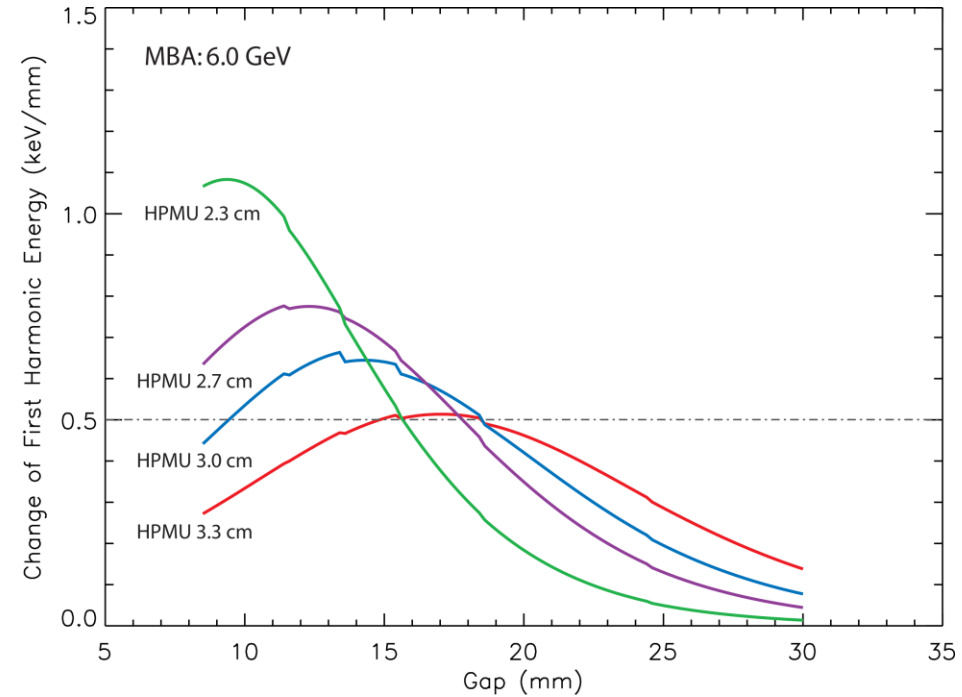
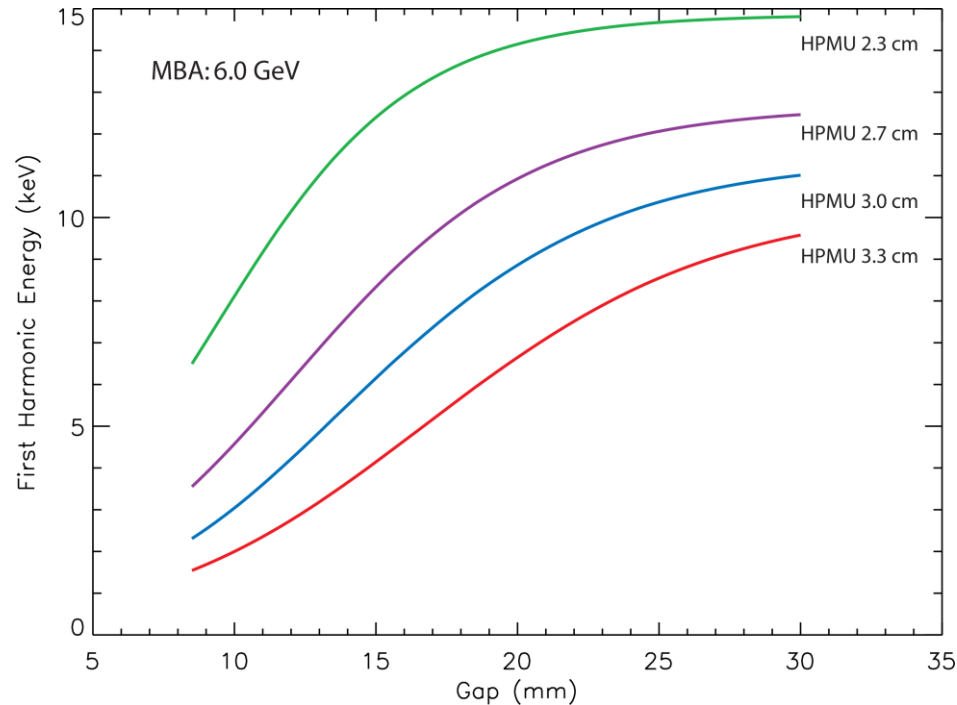

First harmonic vs. gap at 6 GeV for typical HPMU period lengths (effective magnetic fields from Hall probe measurements for gaps >10.5 mm; extrapolated for smaller gaps)

Change of first harmonic energy vs. gap at 6 GeV

- Some users may demand fast energy scans; current maximum undulator gap speed ~1 mm/s ~0.5 keV/s (sufficient for most)
- Gap repeatability is <math><3 \mu\text{m}</math> (~3 eV) (sufficient for most)

Magnetic Measurements and Field Quality

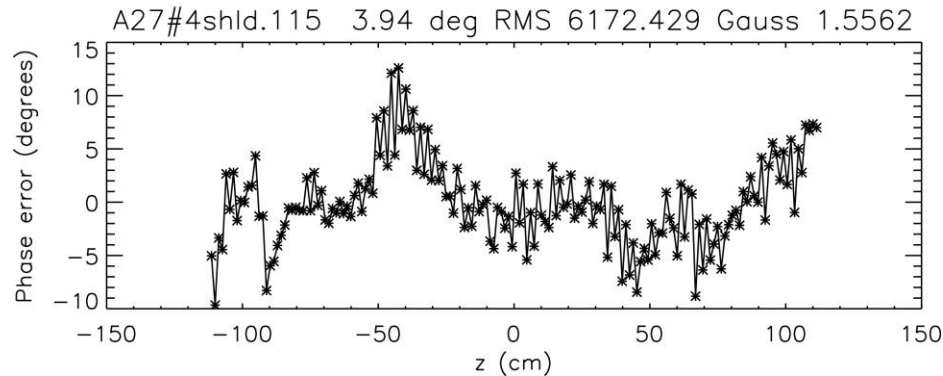
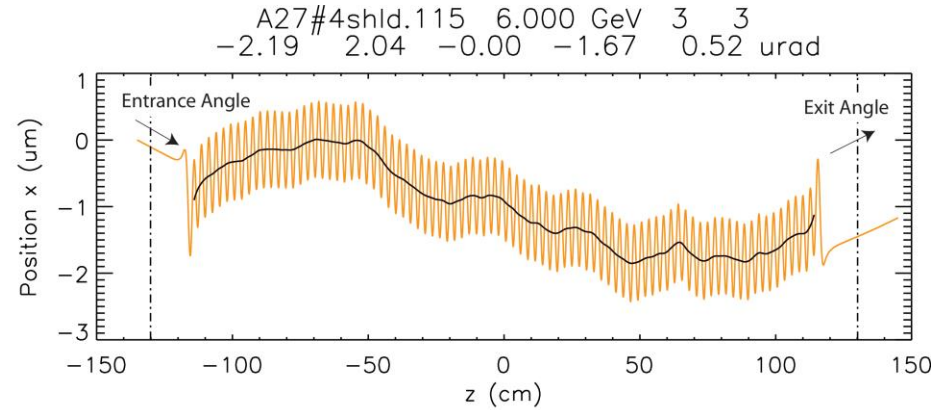

Trajectory (top), phase error (bottom)

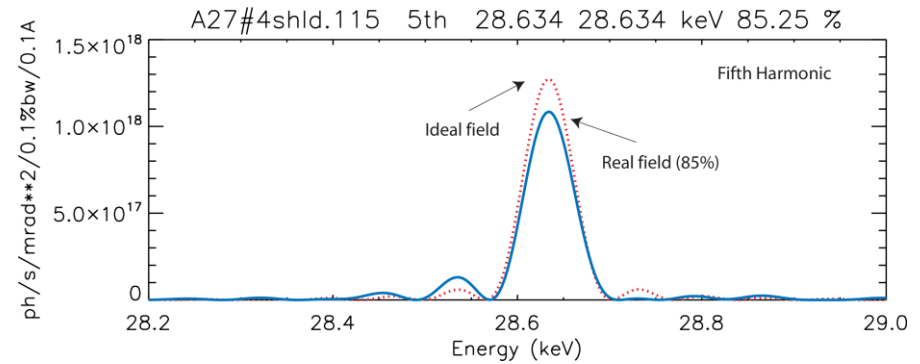
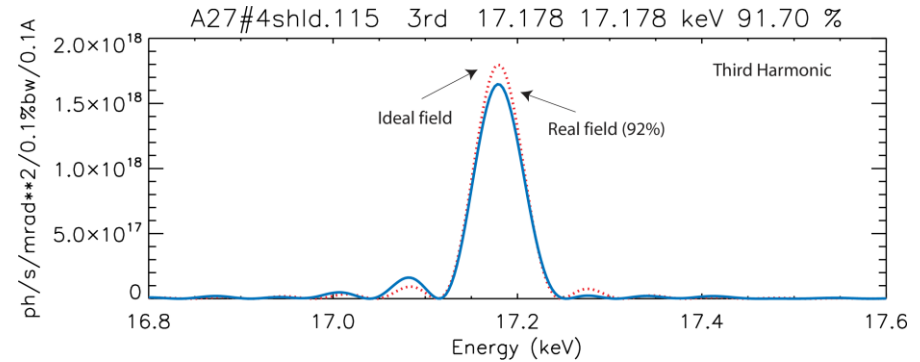

Third harmonic (top) and fifth (bottom)

Typical undulator performance (APS27#4, gap 11.5 mm, from Hall probe measurement)
Entrance angle $-2.19 \mu\text{rad}$ and exit angle $+0.52 \mu\text{rad}$
RMS phase error 3.94 degrees, effective magnetic field 6172 Gauss
Harmonic intensities 92% (3rd) and 85% (5th) of ideal (zero emittance calculation)

ID Magnetic Design Requirements

- Operational reliability (against radiation-induced demagnetization)
- Continuous energy tuning between first and third harmonics
- Minimize attractive forces -> speed up magnetic tuning

N Series ... Product Range of Grain Boundary Diffusion Process (GBDP) Grades

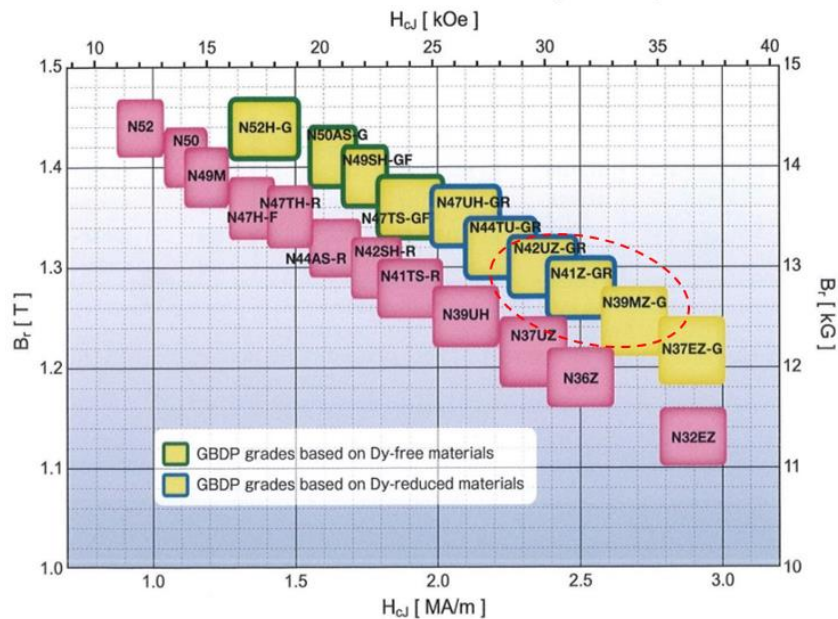

If the field strength required for an undulator can be easily met with a lower remanence B_r magnet grade, the corresponding higher coercivity is desirable to prevent against potential radiation-induced demagnetization. A B_{eff} of 9074 Gauss is sufficient for closing the energy tuning gap between first and third harmonics. Grade N41Z-GR (or equivalent) with remanence $B_r \sim 1.25$ Tesla and intrinsic coercivity $H_{cJ} \sim 30$ kOe/22.5 kOe for surface <3 mm/bulk chosen.

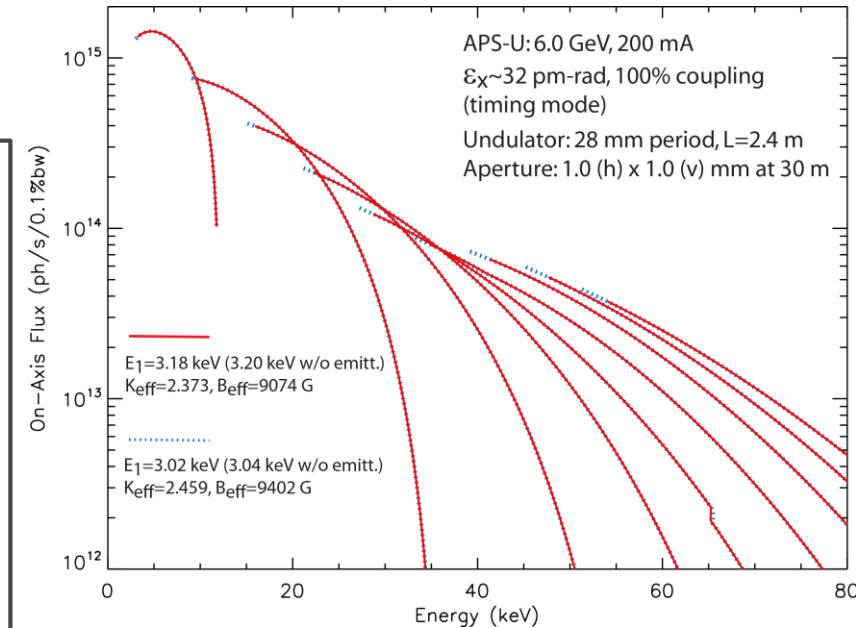

On-axis flux tuning curves of odd harmonics for U2.8 cm (U28) for two effective magnetic fields (B_{eff}) at 8.5 mm magnetic gap.

Good choice of magnet grades considered for the APS-U are circled by the red dashed curve: N42UZ-GR, N41Z-GR, and N39MZ-G, with corresponding base grades of N42SH-R, N41TS-R, and N39UH. (Reference: MD-TN-2017-007)