

PSC ALL-HANDS MEETING APRIL 26, 2017



STEPHEN STREIFFER
Associate Laboratory Director, Photon Sciences
Director, Advanced Photon Source

ADMINISTRATIVE PROFESSIONALS ROCK!!

THANK YOU!!!!

AGENDA

- Safety (S. Streiffer)
- PSC News & Updates (S. Streiffer)
- D&I Working Group Report (P. Fernandez)
- APS-U Update (S. Streiffer)
- Outlook (S. Streiffer)
- Party!

SAFETY

- PSC continues to experience fewer injuries than last year
 - Single recordable injury since October – did not result in any days away or restricted duty time
 - Had 7 injuries by this time last year - 4 involved days away or restricted duty time
- ISO Certification auditor noted improvements in housekeeping, signage, and satellite accumulation areas from last year's ISO certification audit
 - No findings related to APS
- DOE's Office of Enterprise Assessments from HQ is performing a site wide review of work planning and control processes, machine shop operations, corrective actions taken in response to previous radiation protection program assessment findings
 - Has included the APS ESAF process, user machine shops, beamline operations, and use of "skill-of-the-worker" evaluations
 - Will fully consider any resultant findings and suggestions

ESH CHANGES

- Argonne is reorganizing its central services, including ESH
 - Directorate and division/department safety personnel transferring to a new Health, Safety, and Environment Division (HSE) as a deployed service
 - Directorate level was transferred on January 31
 - Division/department level being transferred as of May 1
- Immediate impact involves how cost and time reporting will be performed for these individuals
- Will be a broad service level agreement with all programmatic directorates that identifies the core services which will be provided by deployed HSE staff as well as additional services which can be provided upon request
 - Details are still being finalized
- Biggest PSC challenge is replacing two individuals who will be retiring

THE APS IS THE U.S DOE'S MOST-USED LIGHT SOURCE

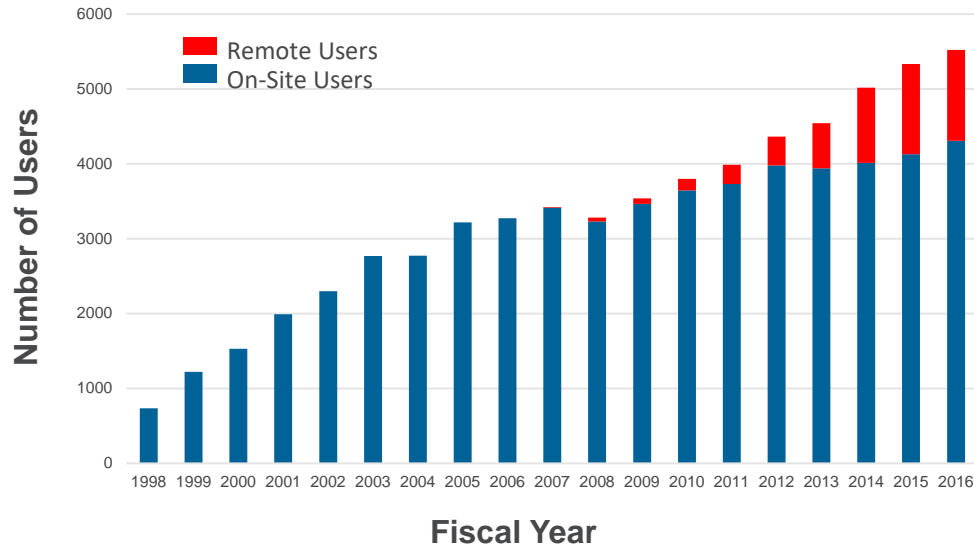
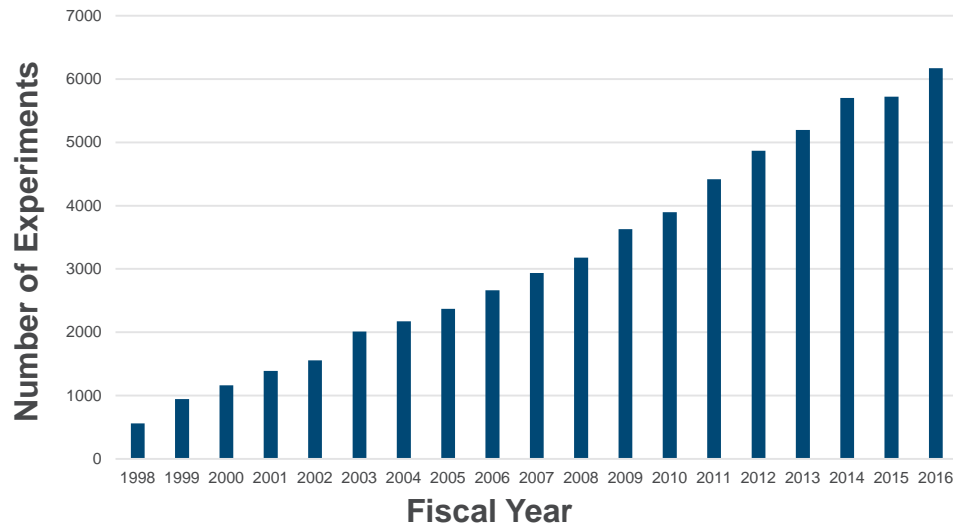

*Prior to FY14, mail-in users were not included in the Remote category

In FY2016:

- >22,600 visits by >5500 unique users
- >6100 experiments
- >19,900 protein structure deposits
- 68 operating beamlines, 5,000 hours
- >181 (unique) industrial users in FY16 from pharma, energy, electronics, materials...
- >20,000 (to date) journal publications; 21% in high-impact journals (25,330 total publications)

**ALL OF THAT IS THANKS TO YOU, OUR
STAFF AND USERS**

APS X-RAY AVAILABILITY AND MEAN TIME BETWEEN FAULTS

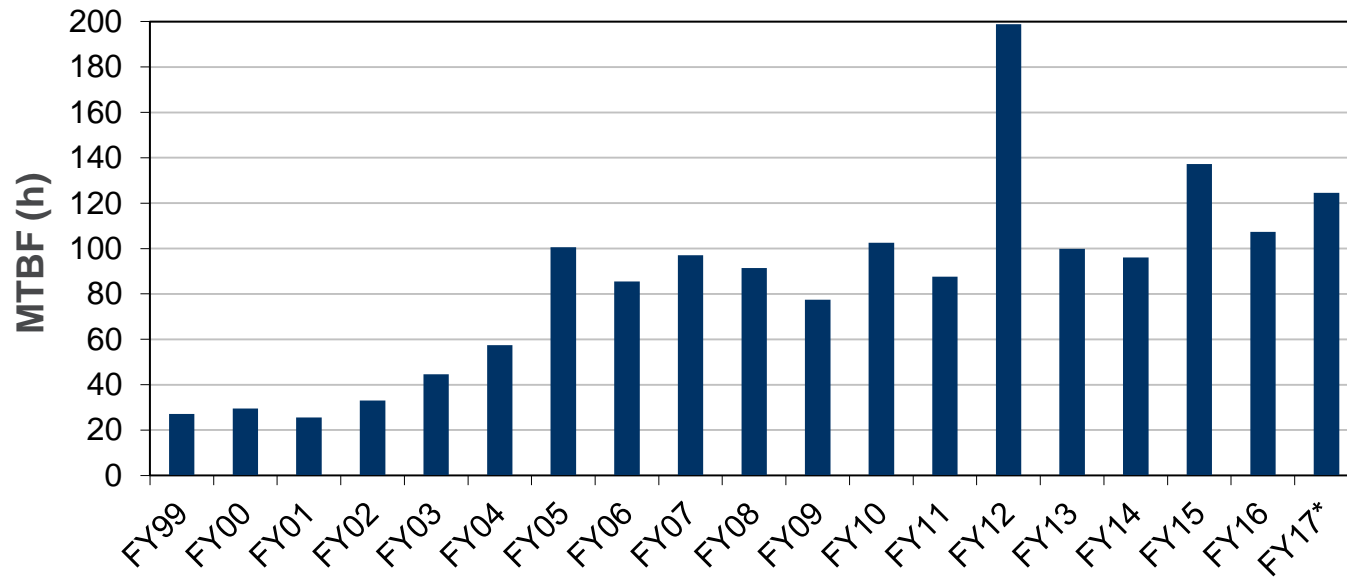
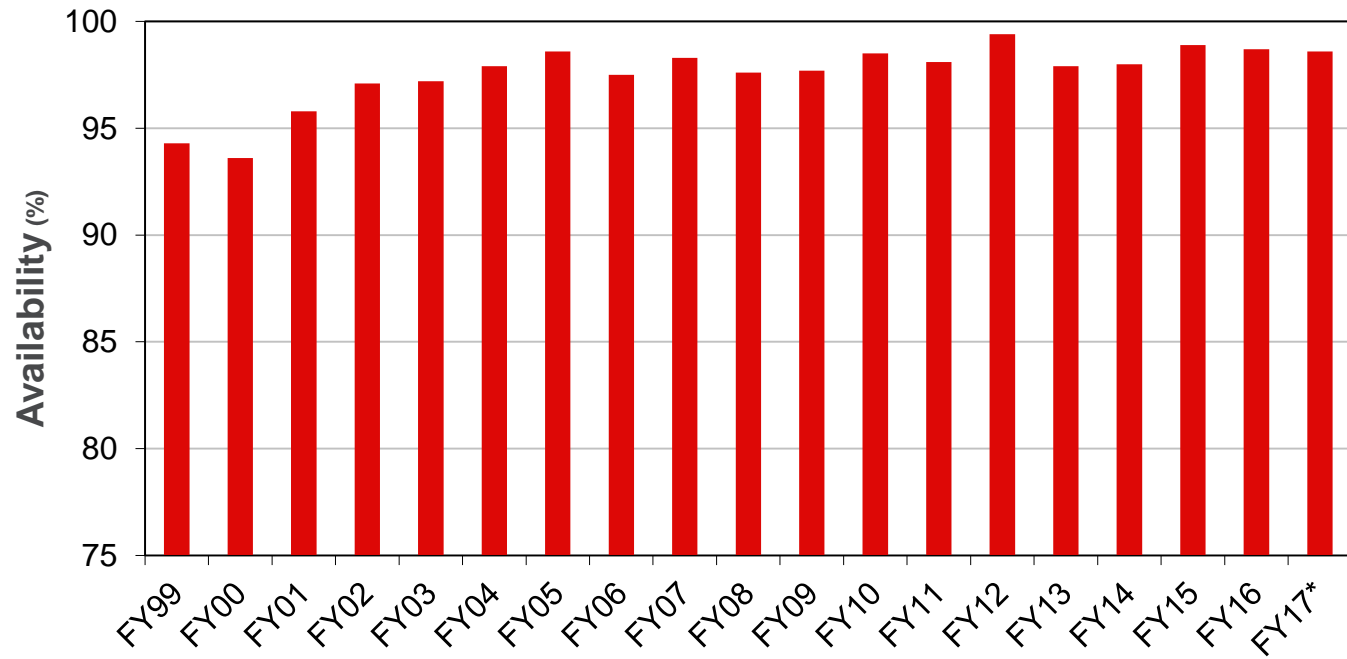

Fiscal Year

*2 runs in FY17

APS X-RAY AVAILABILITY AND MEAN TIME BETWEEN FAULTS



2017-1: No rf faults during user operations and

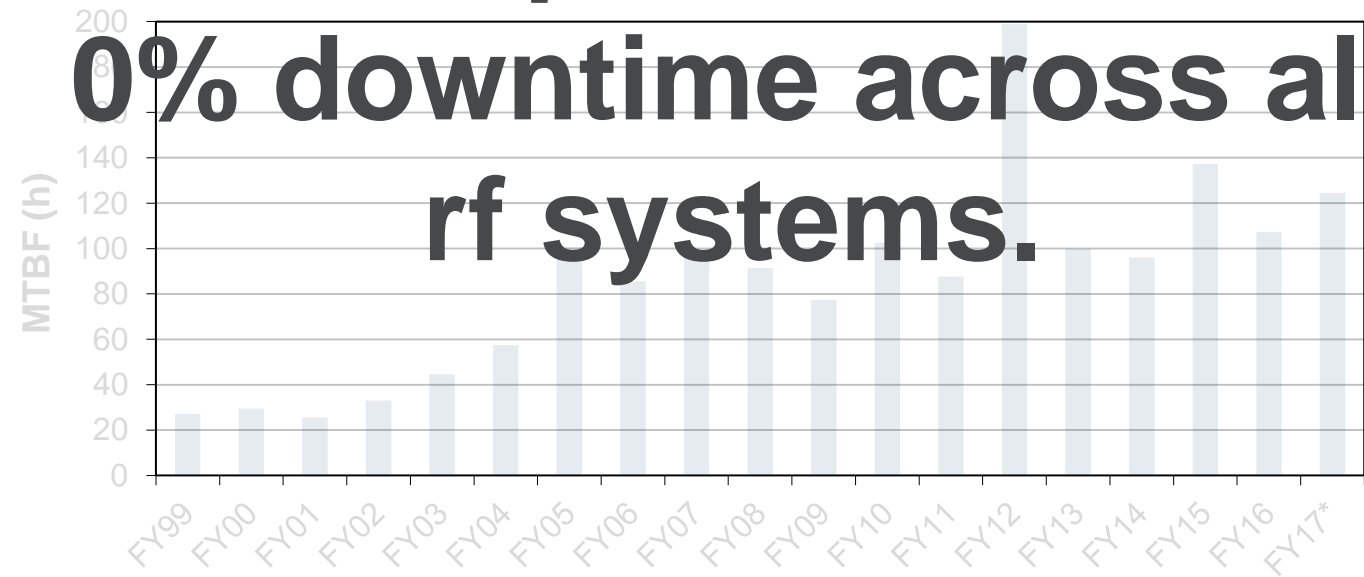

0% downtime across all rf systems.

Fiscal Year

*2 runs in FY17

ASD DIVISION DIRECTOR SEARCH - UPDATE

- The Search Committee has completed on-site interviews
 - 8 applicants considered
 - 6 individuals made the trip to Argonne
- Committee made recommendations on February 10
- Offer in process

SEARCH COMMITTEE MEMBERS

- **Stuart Henderson** – **Committee Chair**, Director, APS Upgrade Project
- **Michael Borland**, Associate Division Director, Accelerator Systems Division
- **Louis Emery**, Storage Ring Manager, Accelerator Systems Division
- **Patricia Fernandez**, Associate Division Director, X-ray Science Division
- **Bob Hettel**, Head of the Accelerator Research Division, SLAC National Accelerator Laboratory (Chair, Machine Advisory Committee for APS)
- **Geoff Pile**, Associate Division Director, APS Engineering Support Division
- **John Power**, Physicist, High Energy Physics Division, Argonne National Laboratory
- **Mark Rivers**, Executive Director of the Center for Advanced Radiation Sources (CARS), The University of Chicago

APS-U PROJECT DIRECTOR SEARCH - UPDATE

- Stuart Henderson named Director, JLab
- Search committee launched
- Building list of potential candidates, starting to assess interest

STRATEGIC APPROACH TO RESOURCE ALLOCATION

Executing APS Mission requires strategic planning at all levels

Divisions propose Strategic Projects to achieve long-term goals

The Resource Evaluation Group evaluates and facilitates Strategic Projects

PSC Senior Management Team prioritizes and approves

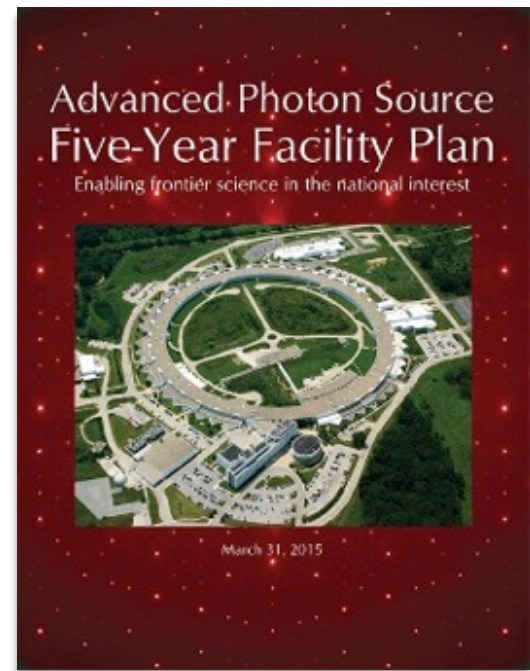

RESOURCE EVALUATION GROUP VALUE PROPOSITION

- Disciplined and consistent process to evaluate and monitor projects
 - Efficiency
 - Accountability
- REG serves as the APS operations project office arm of the SMT
- All strategic projects that exceed established thresholds in effort or M&S must run through the REG.
- Currently thresholds are
 - M&S > \$50,000
 - Effort > 300 hours
- The process is continually evolving. The goal is a light touch. PMs work without direct oversight, but are asked to self evaluate, and are offered guidance, mentoring, and a venue for requesting additional resources if the project scope changes

REG METHOD AND MEMBERSHIP

- Evaluates effort, materials, and contracted services estimates and overall schedule
- Helps to balance resources among projects, taking into account APS priorities
- Determines the necessary reviews and documentation required by each project and, using a graded approach, ensures that each project follows the process.
- Monitors and assists (as needed) project progress, including project coordinator and control account manager (CAM) mentoring.
- Collects project metrics and feedback from stakeholders and acts to improve the process.
- Facilitates project-related communication between divisions, groups, and the ALD office

Member	Backup	Role
Julie Cross		Chair
Kelly Jaje		Administrative Support
TBD*		Project Management
Patricia Fernandez	Jonathan Lang	XSD Representative
Ali Nassiri	Michael Borland	ASD Representative
Geoff Pile	John Maclean	AES Representative
Herman Cease	Jim Kerby	APS Upgrade Project Representative
Bill Berg		Integration: Accelerator
Chuck Kurtz		Integration: Beamlines
Steve Shoaf		Integration: Software
Michael Fisher		Subject Matter Expert Lead: Beamlines
John Grimmer		Subject Matter Expert Lead: Insertion devices, magnets, vacuum chambers, etc.
Geoff Waldschmidt		Subject Matter Expert Lead: Radio frequency, modeling, theory, etc.

*For Kevin D'Amico

EXAMPLE: XTIP PROJECT SCOPE AND SCHEDULE CHANGE

- XTIP example (new beamline on 4-ID for SX-STM instrument)
 - scope change: add diagnostics
 - schedule change: FE installation pushed back by one shutdown

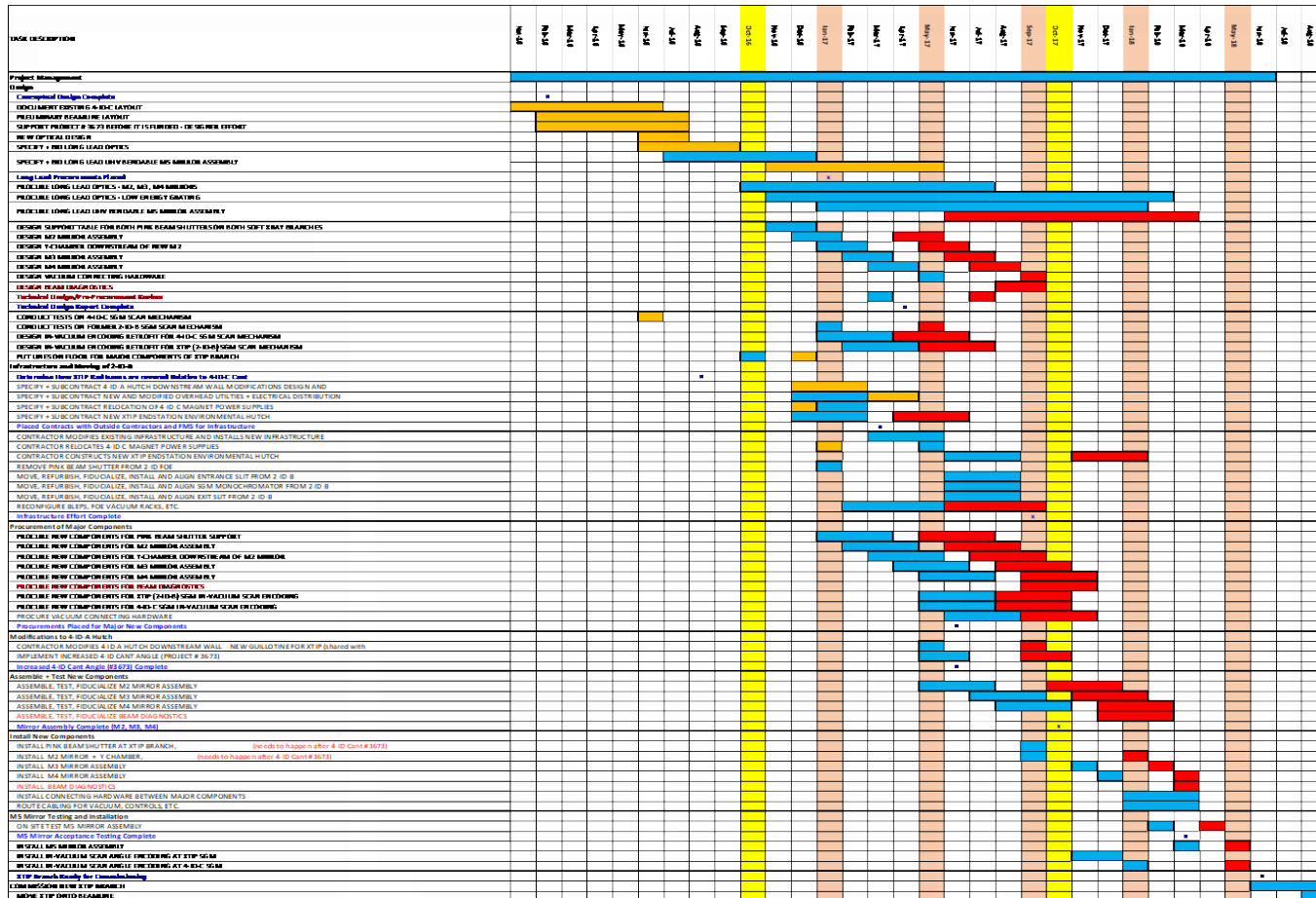

NEW TASK - BEAM DIAGNOSTICS ADDED BY MEI
 COMPLETED OR CURRENTLY IN SCHEDULE TASK
 TASKS AS PLANNED ON ORIGINAL SCHEDULE
 TASKS THAT SIPPED FROM ORIGINAL SCHEDULE

AES UPDATE



LTHW SUPPLY & RETURN LINE REPAIRS



- Inner carbon steel carrier pipe, circled at left, on both low-temperature heating water (LTHW) supply and return lines is significantly corroded, requiring replacement.
- APS has requested that ANL Infrastructure Services (IS) replace the ~370 ft of piping on both the LTHW supply and return lines from Bldg. 450 to the APS pipe vault adjacent to the Experiment Hall.
- IS currently formulating project plan, SOW, bid package to start in the near term. To maintain supply and minimize any disruption to operations a boiler will likely be rented and connected via the APS pipe vault to maintain LTHW supply and piping can be replaced without waiting for an APS scheduled shutdown period. Work is expected to be completed before the APS August/September scheduled shutdown.



Large flakes that have fallen off the OD of the LTHW carrier pipe, showing corroded carbon steel mixed with matted (wet) insulation (above and right)



APS construction photo (undated) showing bank of piping, outlined in yellow box above, that includes the LTHW supply and return from Bldg. 450 to the APS pipe vault.



- Exploratory excavation started on March 29 2017 in order to locate leak of approximately 5.6-5.8 gpm.
- During excavation, extent of pipe corrosion was revealed as well as other conditions, such as weld failures and LTHW pipe settlement at connections to outside wall of Bldg. 450, where LTHW supply originates, shown at left in red boxes.
- Source of the leak was discovered April 13 2017 on the supply line, just after the LTHW expansion loop. The red circles below highlight the leak origination hole after weld prep (below, left) and welded plate cover to contain leak (right) as of April 13 2017.



APS COLLABORATION WITH ANL COMPUTING RESEARCH CENTER (LCRC)

- Roger Sersted from AES IT is collaborating with Argonne's Laboratory Computing Resource Center (LCRC) on the management of the LCRC Clusters
- Rogers expertise will provide improved support for XSD beamlines using the LCRC HPC resources, in addition to Sinisa Veseli's collaboration on behalf of XSD.

NETWORKING

- Installed and configured new Next-Generation Firewall to protect the Accelerator Network
- Added direct 40Gbps connection for beamline data transfer to the Bldg. 240 Computing Clusters (Would allow transfer of approximately 40 hours of HD movies per second)

STORAGE FROM ALCF RECONFIGURED BY AES IT FOR SUPPORT OF APS BEAMLINE DATA

- DDN: Data Direct Networks – high performance storage systems
- GPFS: General Parallel File System – high performance/advanced file system developed by IBM



- DDN racks and servers reside in building 369; 4 DDN racks, each with 510 disks; 1.5 petabytes of storage; 5 IBM servers for GPFS; 1 GridFTP server for Globus Online data transfers



SERVICE IMPROVEMENTS FOR BEAMLINES



- Installed a highly reliable NetApp storage appliance for support of beamline data.



- Moved “dserv” servers to a high-availability virtual machine (VM) clusters
- Installed a highly reliable storage appliance for critical beamline operation applications



ASD UPDATE



ASD DIAGNOSTICS GROUP OPEN HOUSE

6 posters
5 demos
>50-60 visitors

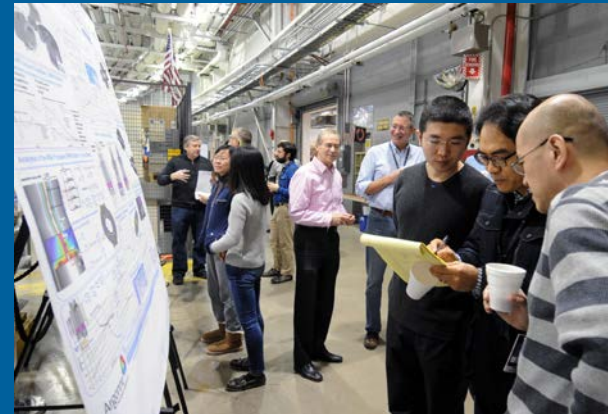
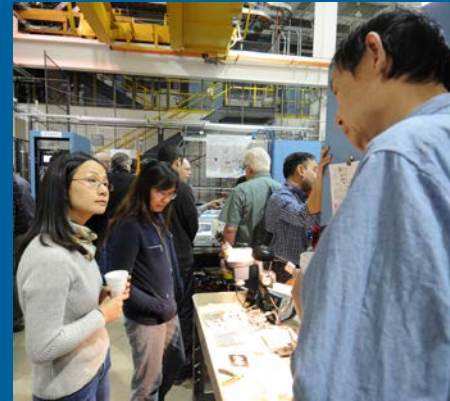
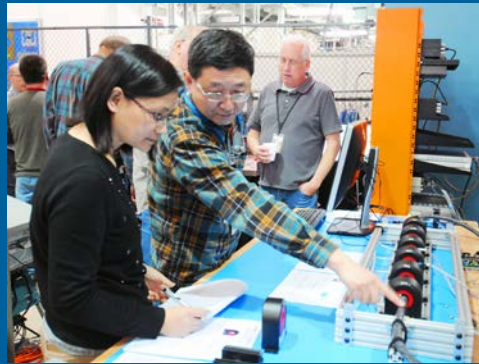

Accelerator Systems Division Magnetic Devices Group OPEN HOUSE

Coming soon

Everyone is invited

WHEN: April 27, 10:00 am - 12:00 pm

WHERE: Magnetic Measurement Lab (MM1) on
The Experimental Hall Floor and Building 314

WHAT: Come See and Discuss the Groups Activities

1. Magnetic device design and simulation
Field simulation (Liz/Nikita/Yuko in MM1); Device design (Mark/John/Aric in 314);
Field analysis (Roger/Nikita in MM1)
2. Superconductor undulator device
Device winding (Matt/Ibrahim in 314) ; Device assembly (Joel/Matt/Quentin in 314);
Device measurement (Matt/Chuck in 314)
3. Conventional magnet device
Coil measurement system (Chuck/Mark/Roger in 314);
Wire measurement system (Chuck/Mark/Roger in 314)
4. Permanent magnet device
Device (planar/revolver) assembly (Mike/John in 314); Field measurement (Isaac/Nikita in MM1)
Integral measurement (Isaac/Nikita in MM1)

HELICAL SCU STATUS

- All HSCU cryostat components have been delivered and passed dimensional and vacuum inspections.
- HSCU cryostat is assembled with all internal components except the helical core (Fig. 1).
- Preliminary data show that the cryostat cools more than twice faster than an SCU0-type cryostat.
- The fabrication of HSCU magnet cores (one for installation and one spare) is being completed (Fig. 2). Winding is in progress.
- The Sector 7 vacuum chamber is pre-assembled including HSCU test vacuum chamber (Fig. 3). It will be installed on the SR in April-May shutdown.

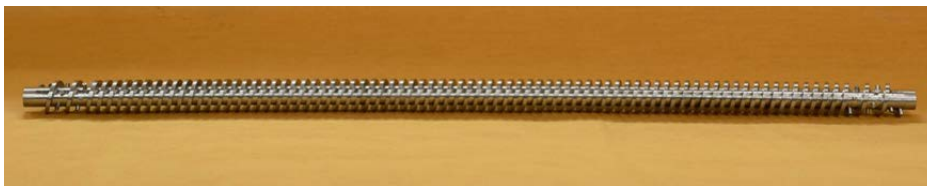

Fig. 2. 1.2-m long HSCU magnet core.



Fig.1. Assembled HSCU cryostat.



Fig. 3. HSCU and APS ID vacuum chambers are assembled at the APS vacuum shop

352-MHZ SOLID STATE RF POWER SYSTEM DEVELOPMENT (LDRD)

Goal:

- ❑ Develop an alternative to vacuum tube technology for generating rf power
- ❑ Improve rf system efficiency and reliability



Methods:

- ❑ Utilize Lateral Diffused Metal Oxide (LDMOS) transistors as rf amplifier devices
- ❑ Design and build a 352-MHz/2kW cw single-device LDMOS amplifier for use as a building block of a larger rf system



2kW Amplifier Modules:

- ❑ Major design challenge is thermal management of the high power dissipation in the transistor package
- ❑ A high-efficiency cold plate/carrier system was designed to cool the transistor and passive components
- ❑ The amplifier design was completed and produced 2.0 kW at 352MHz with 75.4% efficiency



Output Combining Cavity:

- ❑ A design for a multiple-input, 352-MHz, 200kW cw output combining cavity was completed
- ❑ Construction of the first prototype is underway

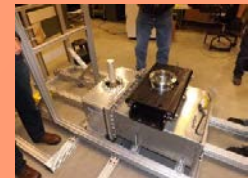
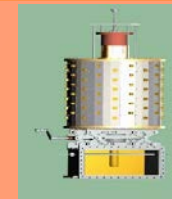

DEVELOPMENT CONTINUED ON THE UPGRADE OF THE BEAM EMERGENCY SHUT-OFF CURRENT MONITOR (BESOCM)

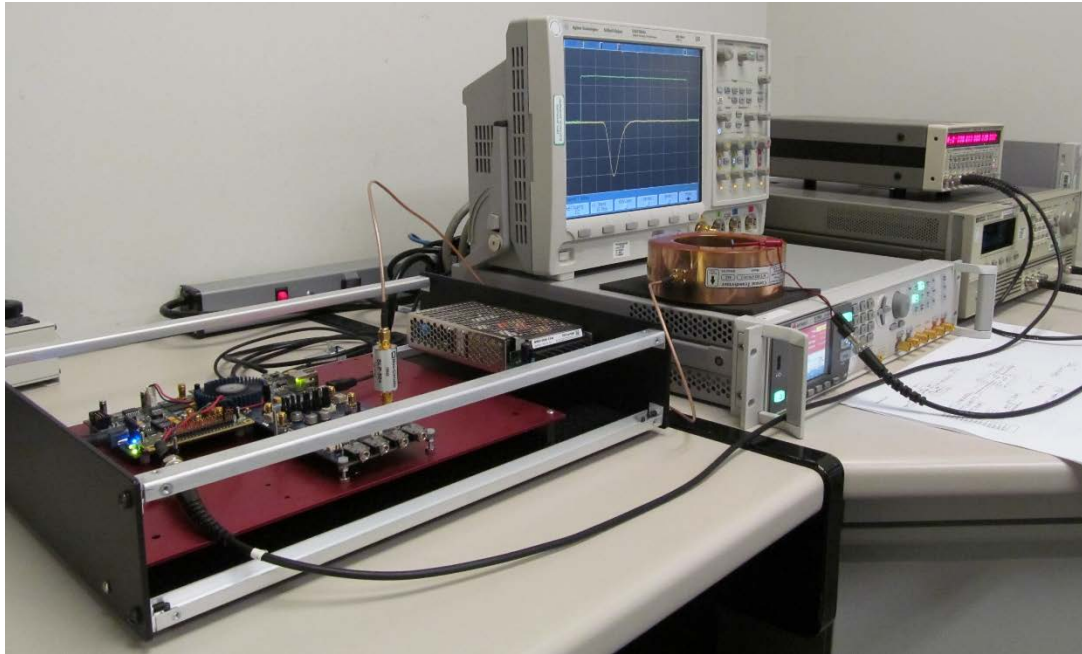

The BESOCM is a radiation safety device that monitors injector charge and generates ACIS trips if the beam current exceeds a safety limit. New electronics will expand operating parameters, such as repetition rate and maximum charge, in order to make the BESOCM system fully compatible with MBA injector operation and injector interleaving operation .

XSD UPDATE

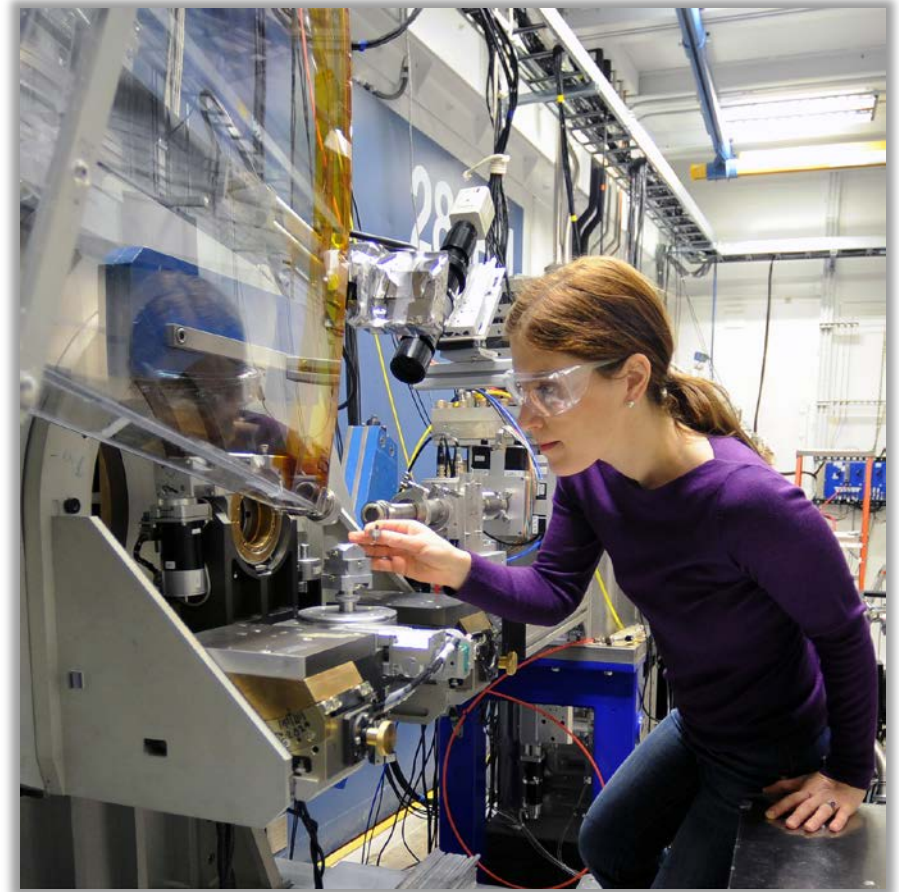

First Observation of Thermally-Activated Domain Wall Motion in Ferroelectric/Dielectric Perovskite Multilayer

Scientific Achievement

This research found evidence of thermally-activated spontaneous fluctuations in ferroelectric serpentine striped nanodomains.

Significance and Impact

The equilibrium dynamics of ferroelectric nanodomains in a ferroelectric/dielectric $\text{PbTiO}_3/\text{SrTiO}_3$ superlattice is exponentially activated with an activation energy of 0.35 eV. This energy barrier is smaller than both the activation energy for the migration of oxygen ion vacancies and the energy needed to change the directions of domain walls, suggesting that domain motion occurs via the creation and annihilation of topological defects.

Research Detail

- Wide-angle X-ray Photon Correlation Spectroscopy at beamline 8-ID-E was used to reveal the equilibrium dynamics of domain motion on time scales of hours as a function of temperature with a peak scattering rate of 8×10^{-3} photons/s/speckle.

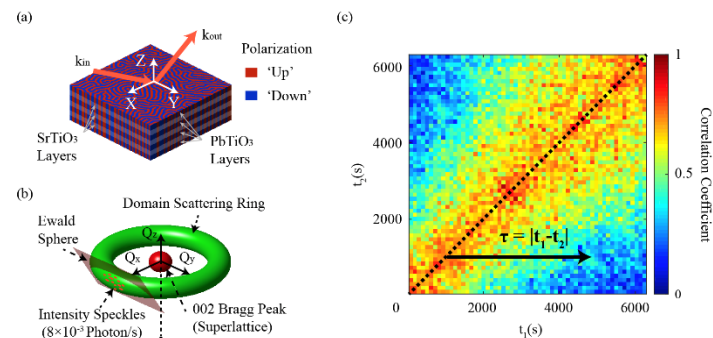

A) Ferroelectric/dielectric multilayer sample with domain pattern and diffraction geometry. B) Domain pattern (donut) around 002 reflection and detector plane cut of Ewald sphere. C) A two-time intensity-intensity correlation function at elevated temperature.

Qingteng Zhang, Eric M. Dufresne, Pice Chen, Joonkyu Park, Margaret P. Cosgriff, Mohammed Yusuf, Yongqi Dong, Dillon D. Fong, Hua Zhou, Zhonghou Cai, Ross J. Harder, Sara J. Callori, Matthew Dawber, Paul G. Evans, and Alec R. Sandy, "Thermal Fluctuations of Ferroelectric Nanodomains in a Ferroelectric-Dielectric $\text{PbTiO}_3/\text{SrTiO}_3$ Superlattice", *Physical Review Letters* 118, 097601 (2017). DOI: 10.1103/PhysRevLett.118.097601

Contact: gzhang234@aps.anl.gov, asandy@anl.gov, dufresne@anl.gov

Work performed at Argonne National Laboratory



U.S. DEPARTMENT OF
ENERGY

Office of
Science



NEW INSIGHTS INTO LYSOSOMAL DISEASE & EBOLA INFECTION

Scientific Achievement

Researchers used x-ray diffraction experiments at SBC-CAT and GM/CA-XSD to build first 3-D structure of the two-pore channel TCP1 protein in a closed conformation.

Significance and Impact

Two-pore channels (TCPs) are voltage-gated ion channel proteins that detect, generate, propagate electrical signals by opening and closing ion pathways across a cell membrane, driving physiological activities, from coordinated heartbeat to processing of sensations and emotions; expands a fundamental understanding of TPCs and provides avenue for targeting TCP1 in lysosomal diseases and release of Ebola virus from lysosomes into host cell

Research Detail

- Obtained a high-resolution x-ray structure of a plant TPC channel from *Arabidopsis thaliana* (AtTCP1) with a comprehensive characterization of channel activity.

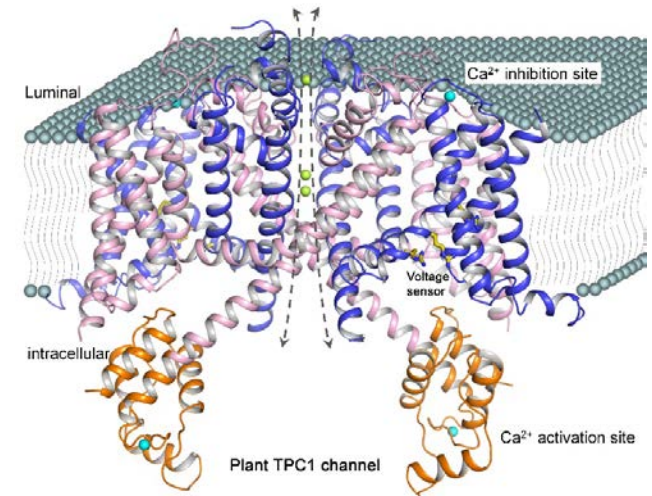

Side view of the AtTCP1 channel dimer. The six-trans-membrane domains (blue and pink) pass through the vacuolar membrane (teal spheres) where they form a channel that permits the passage of Na⁺, K⁺ and Ca²⁺. The intracellular EF hands (orange) contain the Ca²⁺ activation site (cyan), and Ca²⁺ inhibition site is indicated on the luminal side of the membrane.

J. Guo, W. Zeng, Q. Chen, C. Lee, L. Chen, Y. Yang, C. Cang, D. Ren, Y. Jiang, "Structure of the voltage-gated two-pore channel TPC1 from *Arabidopsis thaliana*," *Nature* **531**, 196 (10 March 2016).
DOI: 10.1038/nature16446

Contact: youxing.jiang@utsouthwestern.edu

BNL/ANL GERMANIUM STRIP DETECTOR AT 6-BM

- BNL/ ANL collaboration developed a 1D 64 element germanium energy resolving detector.
- Enables parallel collection of spatially resolved energy dispersive diffraction.
- Used to characterize engineering materials and biomaterials (e.g. bone)

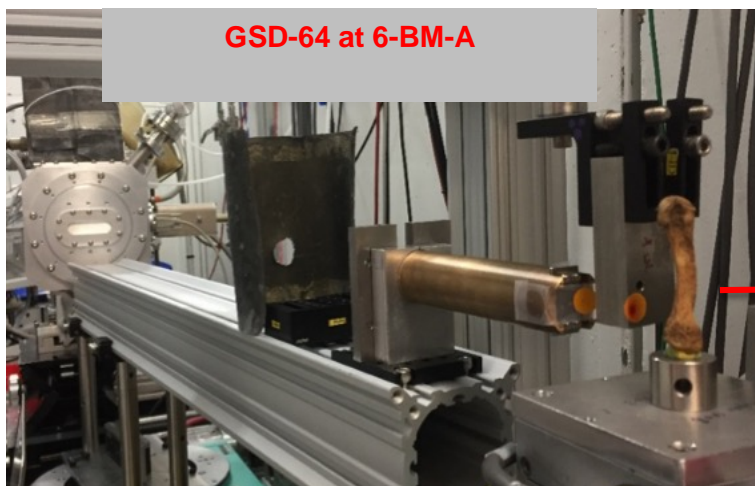

Germanium Strip Detector (far left) and human bone from Roman-era cemetery in the UK (far right)

Ge Strip Detector (64-strip)

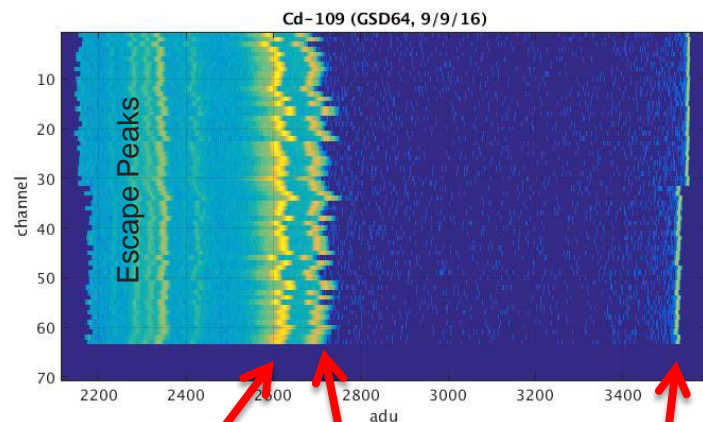

22.1 keV 24.9 keV ~60 keV (saturated)

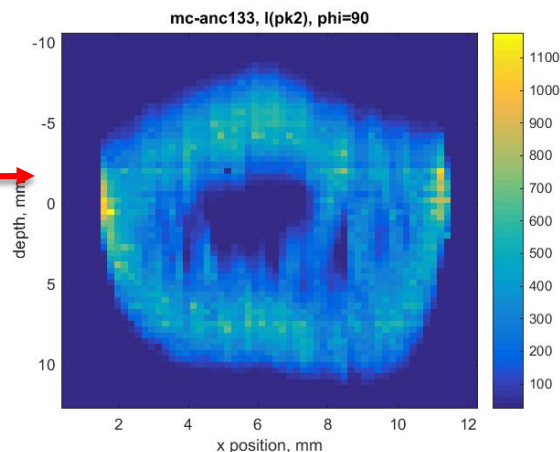

Real space reconstruction of bone

P. Siddons (BNL), J. Baldwin, A. Miceli, O. Quaranta, R.Woods, (XSD-DET) J. Okasinski, J. Almer (XSD-MPE), S. Stock (NU).

MODULAR DEPOSITION SYSTEM

Machine has been “commissioned”

- Controls are working with some bugs being resolved. Automation gradually being added/integrated
- All subsystems have been tested
- **1st multilayer fabricated and delivered (14ID)**
- Source optimization, deposition parameters tuning ongoing
- Ready for velocity profiling (for lateral gradients)

1st Plasma

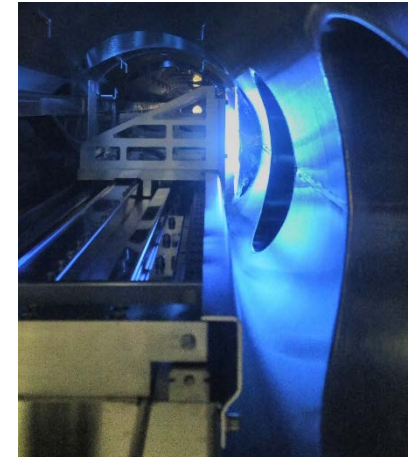

Mo/Si x 250 bilayers. 8keV (CuK α_1)

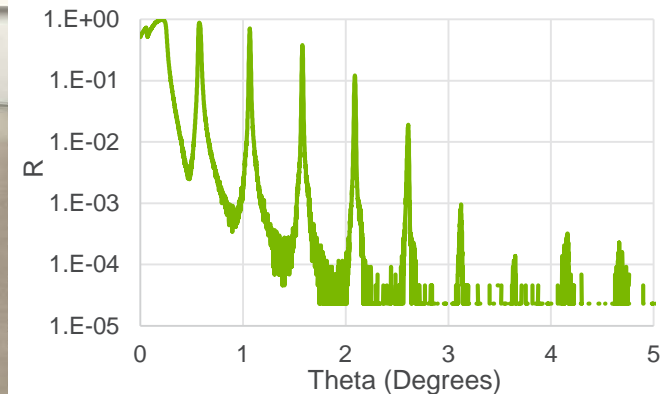

(Top) ML design. (Bottom) Reflectivity curve

VELOCIPROBE INSTALLATION IN 2-ID-D

Velociprobe (installed Jan. 2017) is prototype towards integrating optics, positioning, rapid-scanning, and data acquisition in one instrument

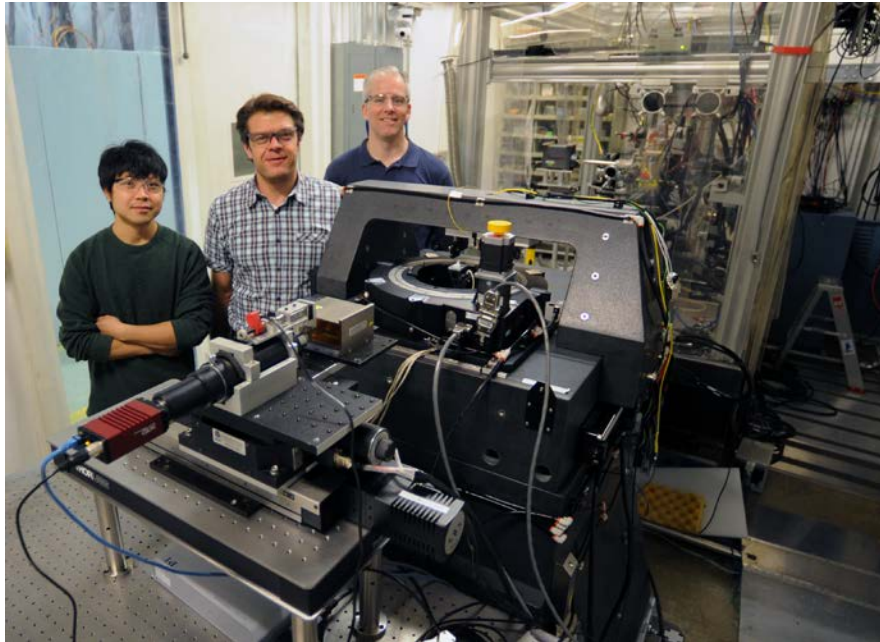

Junjing Deng (MIC), Curt Preissner (BI), and Chris Roehrig (MIC) & many more not pictured

Goals:

- Perform 1- μm^2 ptychographic scans in 10 s with 10-nm resolution
- Achieve 50 nm or better resolution with x-ray fluorescence imaging

First results on test pattern

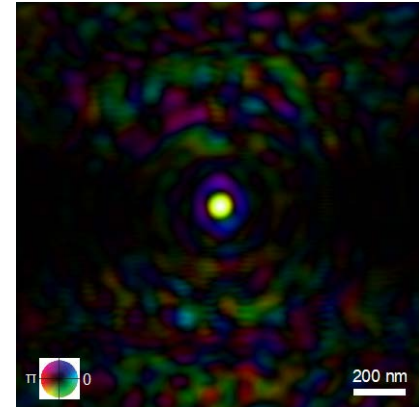

Reconstructed Illumination

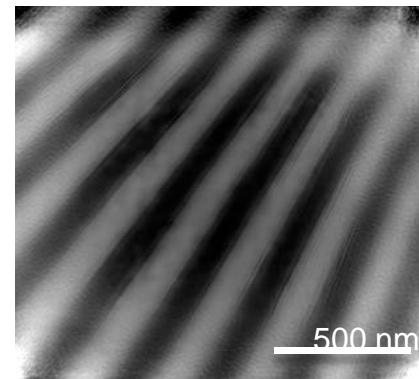

Reconstructed Phase

Ptychographic image with **12.5-nm resolution**

REAL-TIME MONITORING OF METAL 3D PRINTING

- New capabilities for *in situ* probing metal laser powder bed fusion process using high-speed x-ray imaging and diffraction have been developed at 32-ID.
- Melt pool dynamics, powder ejection, rapid solidification, and phase transition could be studied quantitatively

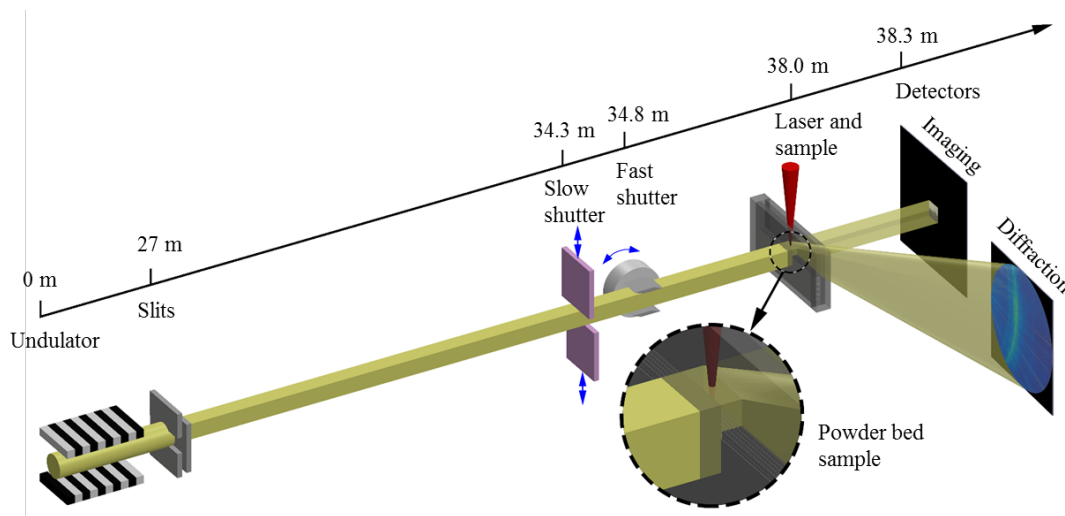

High-speed imaging

High-speed diffraction

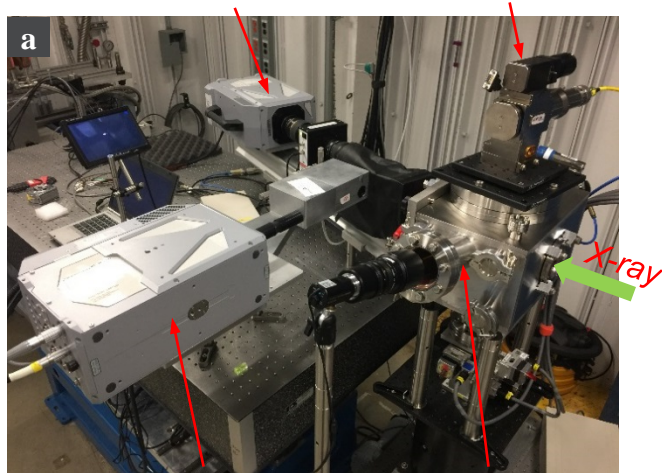

Imaging camera Sample chamber

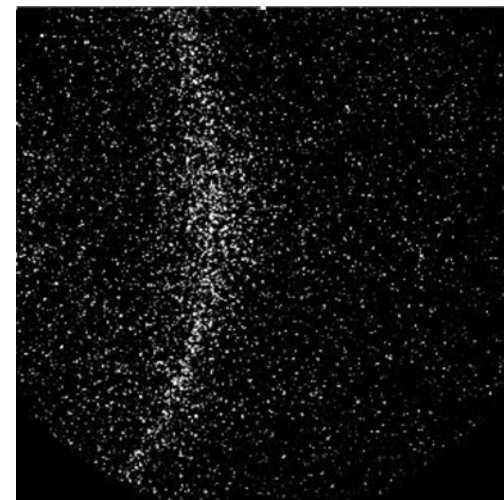
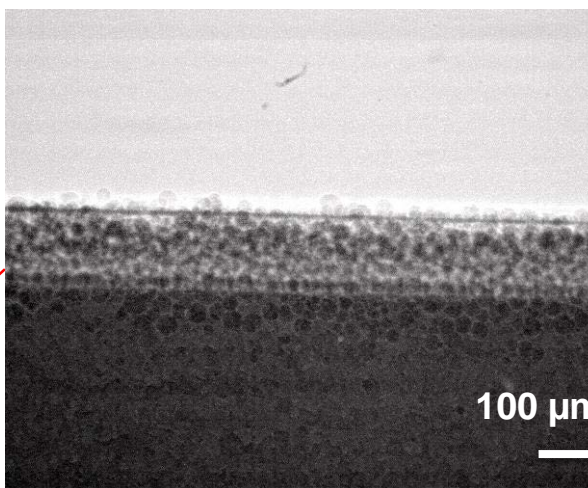

ARGONNE (APS) OUT LOUD

- “Picture This: A Study in Picasso’s Paint” by **Volker Rose** (XSD), part of CPA’s “Argonne Out Loud” series:
 - Drew 580 registrants
 - Boosted registrations by over 78%
 - 81% of guests who responded to post-event survey said the event left them with a favorable impression of Argonne
 - “Well done!” to Volker and the CPA “Argonne Out Loud” crew
- **Watch for the next APS-related “Argonne Out Loud”:**
“25 Years of Drug Discovery at the APS” by **Lisa Keefe** (IMCA-CAT) and **Vincent Stoll** (Abbvie, Inc.) on June 22, 2017

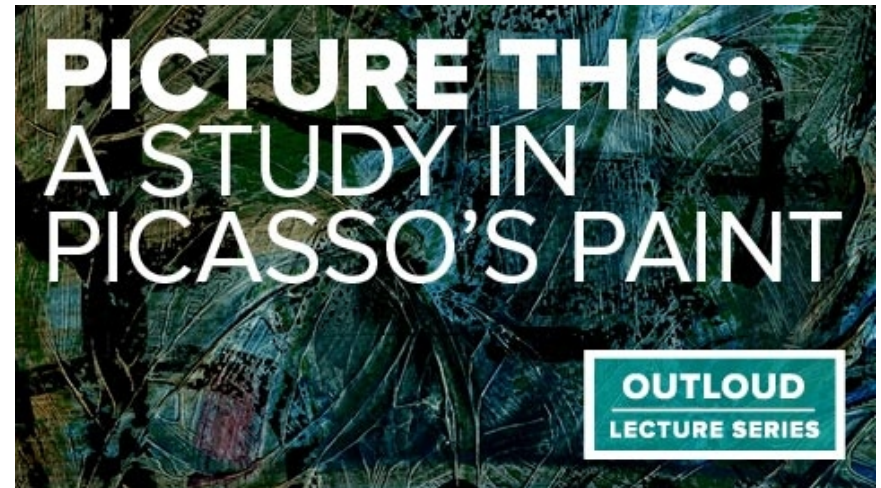

PEOPLE

- **Mark Sutton** (McGill U.), APS user and current Chair of APS Scientific Advisory Committee, has been awarded the 2017 CAP Medal for Lifetime Achievement in Physics by the Canadian Association of Physicists “for pioneering the development of coherent and time-resolved x-ray scattering techniques for the study of materials, and his resulting contributions to our understanding of materials and phase transitions.”
- **Nestor Zaluzec** (PSC) has been awarded the 2017 Distinguished Scientist Award for Physical Sciences by the Microscopy Society of America; and was also named Guest of Honor w/a day-long symposium recognizing his scientific contributions and interests at the PICO2017 conference on “Frontiers of Aberration Corrected Electron Microscopy” in the Netherlands.



PEOPLE

- **Jim Kerby** was appointed as Interim Project Director for the APS Upgrade
- **Uta Ruett** has been appointed XSD Structural Sciences Group Leader
- **Kwang-Je Kim** and **Ryan Lindberg** (both ASD) co-authored, with Z. Huang of SLAC, free-electron laser textbook, *Synchrotron Radiation and Free-Electron Lasers: Principles of Coherent X-Ray Generation*



PEOPLE

- **Michael Merrit** (ASD) and **Oliver Schmidt** (AES) were awarded **Pacesetters** for extraordinary effort resulting in a speedy recovery of the xLEAP wiggler after the truck carrying the wiggler to SLAC was involved in an accident in New Mexico.
- **Dave Gagliano** (XSD) was awarded a **Pacesetter** for providing creative solutions involving design and implementation of electrical circuits for the safe operation of lasers and high-field magnets at beamlines in the MM Group.
- **Stephen Corcoran** (XSD), **Dale Ferguson** (XSD), and **Nagarajan Venugopalan** (XSD) were awarded **Pacesetters** for extraordinary effort in installing vibration dampening under a beamline mirror system, and then replacing the vertical focusing mirror when it developed a “kink.”
- **Si Chen**, (XSD), **Evan Maxey** (XSD), **Chris Roehrig** (XSD), **Kevin Peterson** (XSD), and **Junjing Deng** (XSD) were awarded **Pacesetters** for the expeditious move of the BioNanoprobe to 9-ID-B and its successful commissioning exceeding previous performance.
- **Hanh Bui** (ASD), **Ron Blake** (ASD), **Randy Zabel** (ASD), **Sharon Farrell** (AES), **Robert Laird** (AES), **Anthony Pietryla** (AES), and **Hairong Shang** (ASD) were awarded **Pacesetters** for extraordinary effort and technical creativity adapting the storage ring monopulse bpm upgrade based on FPGA electronics to the booster monopulse bpms.

PEOPLE

- **Damon Simpson** (FMS) was awarded a **Pacesetter** for extraordinary effort in repairing the vacuum chamber leak in Section 5 at Sector 16 of the APS storage ring.
- **Christopher Piatak** (XSD) was awarded a **Pacesetter** for the successful deployment of a scintillator microscope system for the APS detector pool.
- **Jason Ackley** (ASD), **Byron Jordan** (ASD), and **Robert Vargas** (ASD) were awarded **Pacesetters** for extraordinary effort and persistent work over a period of a few years to complete the upgrade of 400 power converters for the storage ring quadrupole magnets.
- **Jonathan Baldwin** (XSD) **Orlando Quaranta** (XSD), and **Russell Woods** (XSD) were awarded **Pacesetters** for the successful deployment of a germanium strip detector system, including the design of a new cryostat, novel sensor mechanical support system, and control and data analysis software.

25+ Years Service Awards

- **Ralph Bechtold, Patricia Cameli, Patricia Fernandez, Joseph Gagliano, Douglas Horan, David Meyer, Anthony Puttkammer, Richard Rosenberg, Martin Smith, Gian Trento, and Mary Westbrook**

DOE-BES TRIENNIAL OPERATIONS REVIEW AND THE UCHICAGO ARGONNE LLC REVIEW

- DOE has notified the APS management that the APS Triennial Operations Review will be held August 15-17, 2017.
- Topics to be covered include
 - Facility performance (schedules, reliability, users participation, etc.)
 - Selected scientific results (posters) of outstanding research performed at the APS
 - R&D plans and future scientific directions
 - Integration/coordination of APS activities
 - ANL plans that may affect APS
- Agenda for the Triennial Review is a work in progress, but we will be requesting science posters from APS and CAT staff.
- To prepare for the DOE/BES review, we will use the UChicago Argonne LLC Review as a dry run.
- The UChicago Argonne LLC Review is scheduled for July 10-12, 2017.

PSC D AND I WORKING GROUP

DIVERSITY

Any difference that makes a difference

INCLUSION

Getting people fully engaged

Co-chairs: R. Bradford and P. Fernandez (both XSD)

Vision – An inclusive work environment, committed to diversity, where everyone feels valued and is empowered to be able to develop their talents, providing the greatest opportunities for the individual, and the greatest benefit to the facility.

Mission – To understand the issues behind the Climate Survey results. To work with PSC management to develop a response plan, and to identify metrics for determining the efficacy of that plan.

Current areas of emphasis:

1. Exclusionary Behavior
2. Leadership Development
3. Commitment to Diversity and Inclusion

Membership Distribution: AES – 7; ASD – 3; XSD – 9; PSC – 9; APS-U – 4.

Total: 32 members, about 20 attend monthly meetings.

Meetings: Monthly open meetings, first meeting on 1 September 2016.

PSC D AND I WORKING GROUP

Work in Progress

- **Inclusive Leadership – Connecting with Others** workshops for PSC
 - Sponsored by the Argonne Leadership Institute (L. Durham).
 - April 12: 50 people attended; May 17: sold out; additional sessions planned.
 - Pre- and post-workshop mini-survey.
 - Very positive feedback from PSC attendees!

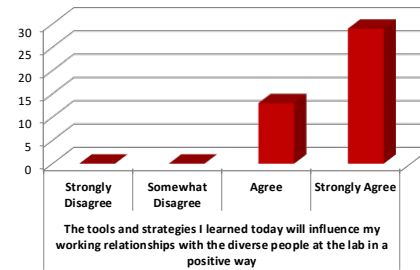
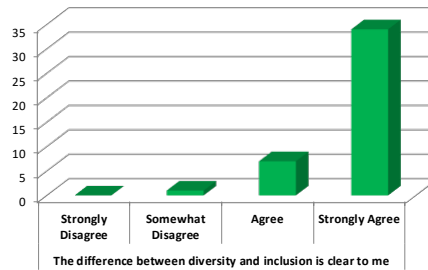
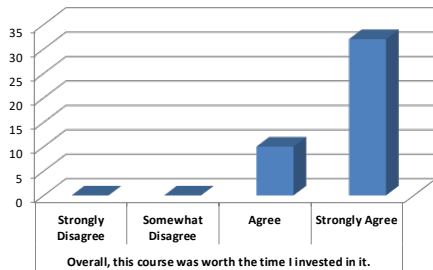

- Working with ALI on a **Respectful Workplace** communication strategy.
- **Showcase different PSC groups** to foster communication and mutual respect.

To do list

- Additional **activities to reinforce inclusion concepts** from the workshop.
- Identify **D&I development opportunities** for supervisors.
- Repeat Climate Survey to gather metrics.

APS Upgrade Project Update



All Hands Meeting
April 26, 2017

APS Upgrade Organization

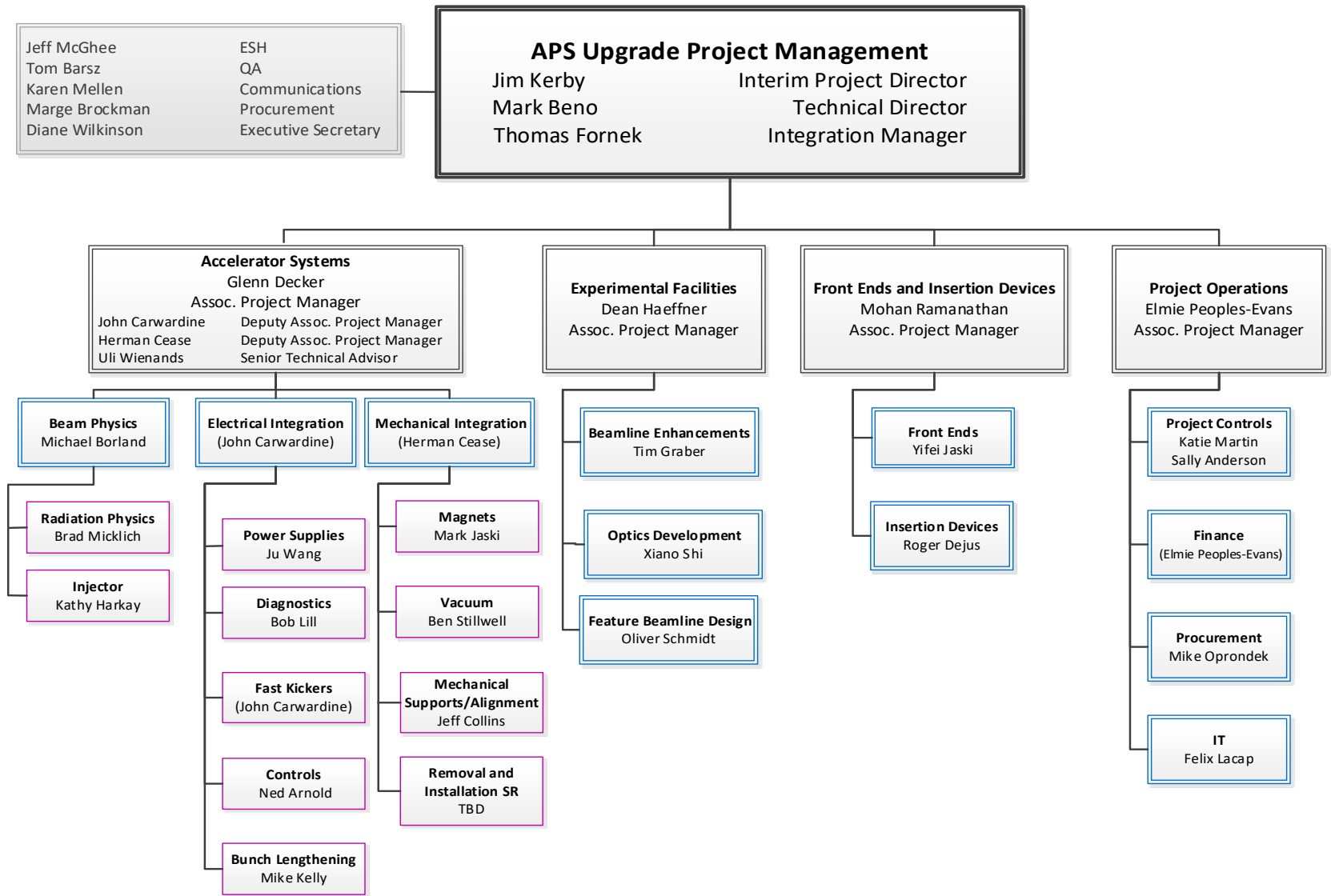

DOE Mini-Review

**DOE Mini-Status Review of the
Advanced Photon Source Upgrade (APS-U) Project**
Germantown, Maryland
March 14, 2017

AGENDA
(note: times listed as EST)

Tuesday, March 14, 2017

1:00 PM	Management Overview	Stuart Henderson
1:30 PM	APS-U Lattice and RF Frequency Choice	Michael Borland/Glenn Decker
3:00 PM	Beamline Roadmap, Beamline Upgrade Schedule, and Long Beamline Detail	Dean Haeffner
3:45 PM	APS-U Installation and Dark Time Planning Update	Stephen Streiffer/Jim Kerby
4:45 PM	Close-out Summary and Recommendations	Review Committee Chair
5:00 PM	Adjourn	All

Committee Members

<input type="checkbox"/> Name	Inst.
Frank Crescenzo	DOE/BHSO
David Fritz	SLAC
David Robin	LBNL
Barbara Thibadeau	ORNL

APS-U Points of Contact

<input type="checkbox"/> Name	ANL Phone	E-mail Address
Stephen Streiffer	2-7990	aps-director@aps.anl.gov
Stuart Henderson	2-7828	hendersons@aps.anl.gov
Jim Kerby	2-5264	jkerby@aps.anl.gov
Glenn Decker	2-6635	decker@aps.anl.gov
Michael Borland	2-4205	borland@aps.anl.gov
Dean Haeffner	2-0126	haeffner@aps.anl.gov

U.S. Department of Energy Office of Science | Office of Basic Energy Sciences | UChicago Argonne LLC

[Privacy & Security Notice](#) | [Contact Us](#)

■ Key Topics for Review

1. Choice of 41pm lattice for inclusion in the Preliminary Design Report
2. Continuing use of 352 MHz RF in the storage ring
3. Preliminary Beamline scientific choices and road mapping

DOE Mini-Review

- The reviewers understood and agreed with the decisions of the APSU on each of these topics, and with the inclusion of them in the Preliminary Design Report

- Key Recommendations:
 1. ANL and U-Chicago leadership should act swiftly to appoint a new project director and complete an adequate transition period before CD-2 baseline.
 2. Develop conceptual design [30% drawings] for the long beamlines building and obtain an independent cost estimate prior to CD-2.
 3. For each of the 8 flagship beamline projects, complete the functional requirements documents, preliminary beamline design, and non-generalized cost & resource loaded schedules prior to CD-2.
 4. Develop a Transition to Operations (TTO) plan for “early” beamline scope prior to CD-2.

DOE Mini-Review Outcome

- Nothing unexpected → the meeting proved to be a good opportunity to inform BES and our lead reviewers of our status and progress
- Next review ‘in the fall’—schedule becomes clearer as the federal budget does
- THANK YOU – we are doing the right things, no course trajectory changes -- let’s keep going!

APS Upgrade Project Schedule

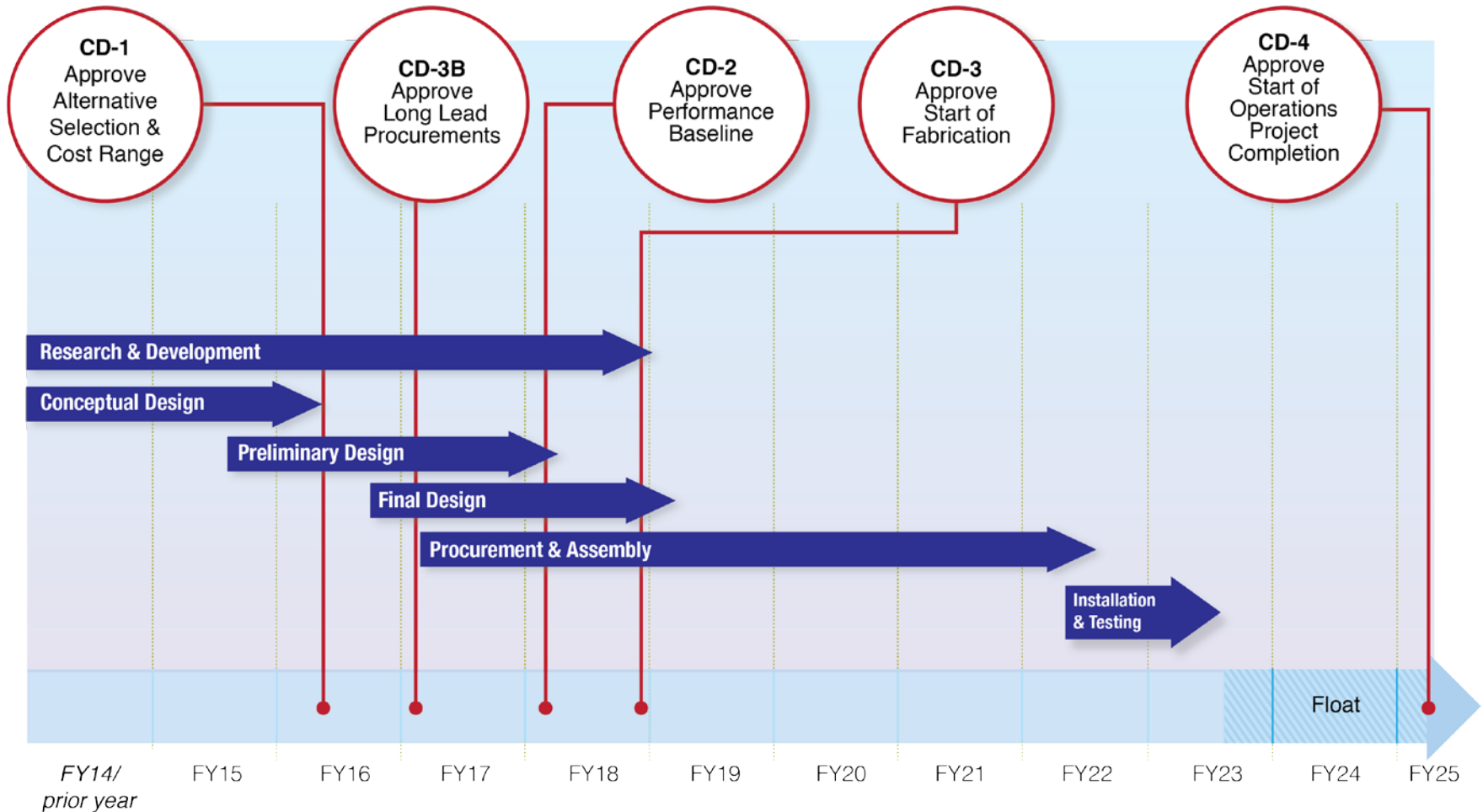

**This schedule is based on proposed funding profile
From the technical point of view the project is ready to proceed more rapidly**

Working Timeline

- November
 - ✓ Complete beamline roadmapping
 - ✓ SAC Meeting Nov. 9-10
 - ✓ Complete Lattice/RF analyses and selection
- December
 - ✓ ESAC Meeting Dec. 1-2
 - ✓ Mini-MAC Meeting Dec. 14-15
 - ✓ Issue Enhancements call for proposals
- January
 - ✓ Begin follow-up prelim design reviews (as needed)
- February
 - 🕒 Project Controls effort on LLP prep
- March
 - ✓ SAC Meeting
 - ✓ DOE “mini”-review
 - 🕒 Complete ES&H/QA doc updates
 - 🕒 Specification/interface docs
 - ✓ Enhancements Review
- April
 - 🕒 Beamline Workshops
- May
 - Complete PDR for review
 - Work plan based on funding profile
- June
 - MAC, ESAC
- July
- August
 - Ops Triennial (Aug 15-17)
 - *(Director’s Review)*
 - *(Finalize documents for DOE Review)*
- September
 - **PDR Reviewed and Accepted (ANL PEMP Reportable)**
 - *DOE Review (tbc)*

OUTLOOK: THE BUDGET SITUATION

APS OPERATIONS – FY17 PLANNED VS ACTUAL SPENDING

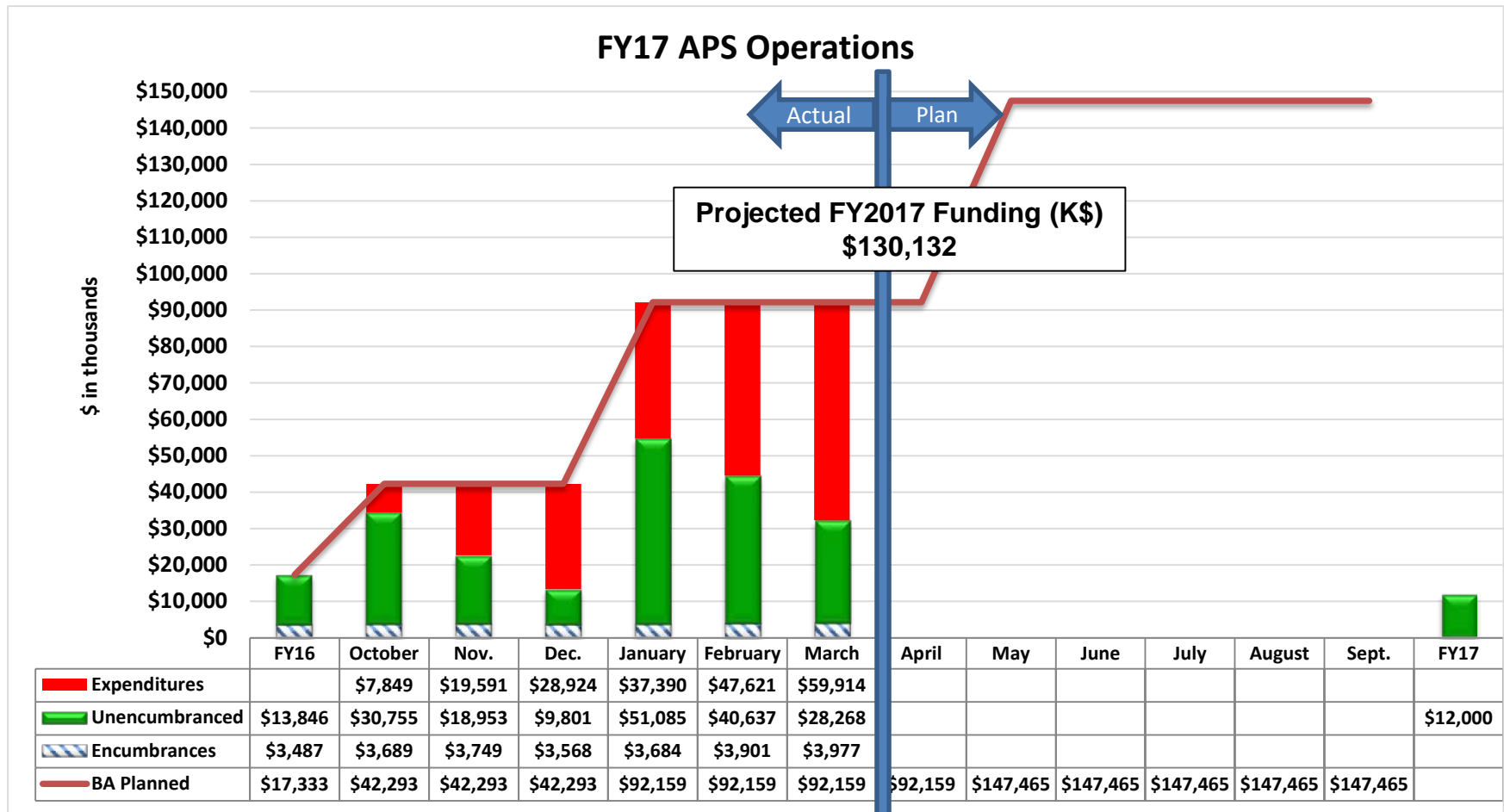

ADMINISTRATION'S FY18 BUDGET BLUEPRINT

In March the Trump administration released its blueprint for the detailed FY18 budget request that will be presented later this spring.

The information is very high-level, giving only department-level top line numbers. The document states the following: "Ensures the Office of Science continues to invest in the highest priority basic science and energy research and development as well as operation and maintenance of existing scientific facilities for the community. *This includes a savings of approximately \$900 million compared to the 2017 annualized CR level.*" This would represent an approximately 20% cut for SC.

This is the first step in the budget debate for FY18. Key Congressional members are on record voicing their support for science funding. In the end, Congress writes budget legislation and authorizes spending, in response to the president's request, with negotiations to follow before a final budget. Reflecting the importance of the APS and APS-U to the country's future, both have very strong bipartisan Congressional support.

Paul Kearns has discussed the Lab's perspective on the upcoming budget negotiations and on redoubled efforts to articulate the critical importance of Argonne to the nation's well-being. If you have any questions, please do not hesitate to contact me or your division leadership.

- Anything you've heard to this point is rumor
- Here are the facts at this time:
 - There is no final federal budget for FY17
 - Nor for FY18
 - But DOE, BES, Argonne, and PSC must plan
 - It is up to us to be prepared
 - So we are preparing for 4 scenarios

- Admin. FY18 budget blueprint reduces SC by 17% relative to FY16
- The resulting scenarios for APS are:
 - Assume 17% reduction applies to all SC programs
 - 10% budget reduction for APS
 - 5% budget reduction for APS
 - Flat budget for APS



We are **PLANNING** for all these scenarios

- But again, right now no one knows what our FY18 budget will be
- As soon as we know the facts (and it will be some time), I will immediately call an All-Hands Meeting specifically to let you know what comes next

- To recap:
 - Anything you hear now about budget plans is speculation, because right now no one knows what our FY18 budget will be
 - Argonne and PSC management are working on various scenarios
 - As soon as we know the facts (and it will be sometime), I will immediately call an All-Hands Meeting specifically to let you all know what comes next

- Until then, thanks to you we will continue to run the best program in the BES user facility system

- Questions?

END-OF-RUN/THE BEST IS YET TO COME PARTY

- Thanks to everyone at the APS for another successful user-beam run
- There are more great accomplishments to come!
- Pizza, soft drinks, water, etc.
- Lower Gallery
- Right now
- Courtesy of everyone who bought an APS t-shirt
- And the people in the User Office who sell them!